

Item	Caixa Caja Box	Qty Ctd Qty	Descrição Descripción Description	Medidas (mm) Dimensions (mm) Size (measurements) (mm)
01	2/2	01	Base Base Base	715x490x15
02	1/2	01	Lateral Esquerda Lateral izquierda Left side	2225x490x15
03	1/2	01	Travessa Inferior Frontal Travesaño inferior delantero Front lower crossbar	684x60x15
04	2/2	01	Base Forno Base del horno Oven base	684x490x15
05	2/2	01	Base Aéreo Base aérea Air base	684x490x15
06	2/2	01	Prateleira Superior Estantería superior Upper shelf	684x490x15
07	1/2	01	Lateral Direita Lateral derecha Right side	2225x490x15
08	2/2	01	Tampo Tapa Top	715x490x15
09	1/2	02	Fundo Cru Fondo crudo Raw bottom	919x353x3
10	2/2	01	Fundo Central Fondo central Central fund	708x477x3
11	2/2	02	Fundo Superior Fondo superior Superior background	428x708x3
12	1/2	02	Travessa Frontal Travesaño delantero Front crossbeam	590x60x15
13	1/2	02	Travessa Lateral Travesaño lateral Side crossbeam	529x60x15
14	1/2	02	Porta Puerta Door	826x354x15
15	1/2	01	Frente de Gaveta Menor Frente de cajón más pequeño Smaller Drawer Front	711x125x15
16	1/2	02	Lado de Gaveta Menor Lado del cajón más pequeño Smaller Drawer Side	400x90x15
17=21	2/2	01	Fundo de gaveta Fondo de cajón Bottom of drawer	640x411x3
18	1/2	01	Ripa de trás Menor Listón trasero más pequeño Smaller back batten	659x90x15
19	1/2	02	Frente de Gaveta Frente de cajón Drawer Front	711x326x15
20	1/2	04	Lado de Gaveta Lado del cajón Drawer Side	400x180x15
21=17	2/2	02	Fundo de gaveta Fondo de cajón Bottom of drawer	640x411x3
22	1/2	02	Ripa de trás Malla detrás Rear lath	659x180x15
23	1/2	01	Ripa Estrutural Gaveta Ripa Estrutural Cajón Drawer Structural Clamp	400x60x15
24	1/2	01	Travessa Sustentação Bandeja de suporte Support Tray	705x50x15

Ferragens | Herrajes | Hardware

A Parafuso 7,0x40mm CHT. Tornillo 7,0x40mm CHT. Screw 7,0x40mm CHT.	B Parafuso 5,0x50mm FLA. Tornillo 5,0x50mm FLA. Screw 5,0x50mm FLA.	C Parafuso 3,5x40mm CHT. Tornillo 3,5x40mm CHT. Screw 3,5x40mm CHT.	D Parafuso 3,5x14mm FLA. Tornillo 3,5x14mm FLA. Screw 3,5x14mm FLA.	E Parafuso 3,5x12mm CHT. Tornillo 3,5x12mm CHT. Screw 3,5x12mm CHT.	F Parafuso 4,0x25mm CHT. Tornillo 4,0x25mm CHT. Screw 4,0x25mm CHT.	G Parafuso 3,0x16mm CHT. Tornillo 3,0x16mm CHT. Screw 3,0x16mm CHT.
H Cavilha 8x25mm Cinta 8x25mm Dowel 8x25mm	I Parafuso 3,0x30mm CHT. Tornillo 3,0x30mm CHT. Screw 3,0x30mm CHT.	J Prego 10x10mm Clavo 10x10mm Nail 10x10mm	K Fixador de fundos Fijador de fondos Bottom fixer	L Cantoneira suporte triangular Cantoneira soporte triangular Triangle support angle	M Parafuso minifix Tornillo minifix Minifix bolt	N Tambor minifix Tambor minifix Minifix drum
O Calço Removível Calzado extraíble Removable Shim	P Dobradica SlideOn Baixa Amortecedor 35mm Bisagra SlideOn Baja Amortiguador 35mm Low SlideOn Hinge 35mm Shock Absorber	Q Parafuso União 30mm Tornillo Unión 30mm Union Screw 30mm	R Conector de Montagem Conector de montaje Mounting Connector	S Suporte de metal soporte metálico metal support	T Suporte de fixação Soporte de fijación Mounting bracket	U Proteção para cantoneira Angulo de protección Protection angle
V Buchas plásticas 8mm Bucha de plástico 8mm 8mm plastic bushing	W Perfil "I" 904mm Perfil "I" 904mm Profile "I" 904mm	X Puxador 707mm Tirador 707mm 707mm Handle	Y Puxador 350mm Tirador 350mm 350mm Handle	Z Corrediça telescópica Diapositivas telescópicas Telescopic slides	AA Pé 145mm x 42mm Pie 145mm x 42mm Foot 145mm x 42mm	AB Sachê de cola Bolsa de pegamento Glue bag
AC Giz de correção Tiza de corrección Chalk of correction	AD Adesivo tapa parafuso 10mm Adhesivo tapón de tornillo 10mm Bolt cover adhesive 10mm	AE Batente PVC para Porta Parada de PVC para Puerta PVC Door Stop	AF Etiqueta resinada Henn Etiqueta resinada Henn Henn resin label			

O parafuso (Q) deve ser usada somente quando este módulo for acoplado a outro módulo componível Henn.

El tornillo (Q) se debe utilizar sólo cuando el módulo está conectado a otro módulo componible Henn.

The screw (Q) should be used only when this module is attached to another Henn modular module.

RECOMENDAÇÃO
Para fixar o móvel na parede usar o suporte de fixação (T), o parafuso 3,5x14mm FLA (D), a Bucha 8mm (V) e o parafuso 5,0x50mm FLA (B).

RECOMENDACIÓN
Para conectar el móvil a la pared con el soporte (T), tornillo 3,5 x14mm FLA (D), el casquillo de 8 mm (V) y el 5,0 x50mm tornillo FLA (B).

RECOMMENDATION
To fix the furniture to the wall use the mounting bracket (T), the 3.5x14mm FLA (D) screw, the 8mm bushing (V) and the 5.0x50mm FLA (B) screw.

HENN

Ind. e Com. de Móveis Henn
Mondai - SC - Brasil

+55 49 3674.3500

@moveishenn
www.henn.com.br

INSTRUÇÕES DE MONTAGEM

INSTRUCCIONES DE MONTAJE
ASSEMBLY INSTRUCTIONS

Torre Quente 1 Forno Belize |
Torre caliente 1 Horno Belize | Hot Tower 1 Oven Belize

C518-131 Cinza
C518-170 Capuccino HP

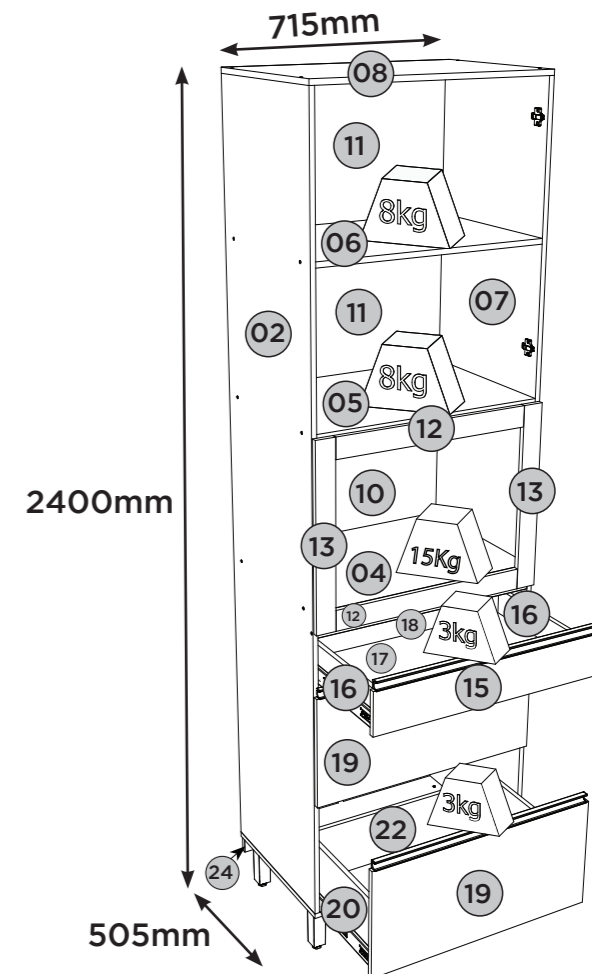
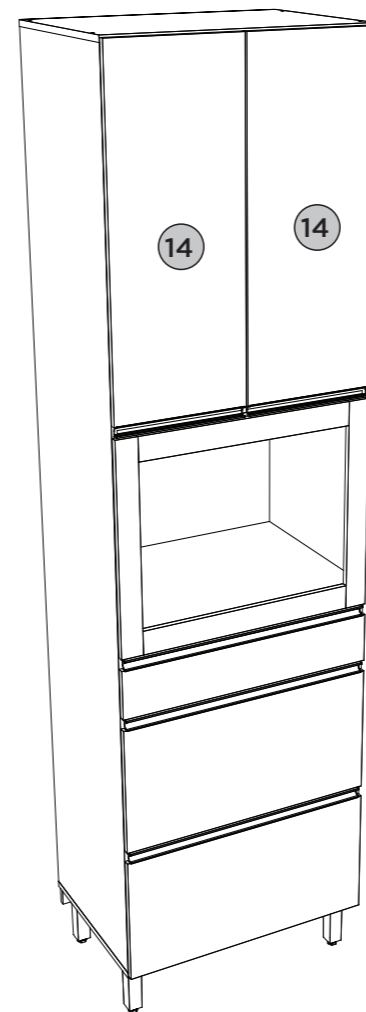

Pesos máximos recomendados com carga distribuída
Peso máximo recomendado con la carga distribuida
Recommended maximum weights with evenly distributed.

AVISO

Para limpeza de seu móvel, use uma flanela seca ou umedecida, e não utilize produtos químicos que possam danificar seu produto.

SISTEMA DE MONTAGEM

O sistema de montagem dos produtos, funciona de acordo com a ordem crescente dos números indicados no desenho. Ex: 01, 02, 03, 04... até a conclusão da montagem.

ADVERTENCIA

Para limpieza de su móvil, use una flanela seca o húmeda, y no utilice productos químicos que puedan dañar su producto.

SISTEMA DE MONTAJE

El sistema de montaje de los productos funciona de acuerdo con el orden creciente de los números indicados en el dibujo. Ej.: 01, 02, 03, 04... hasta la conclusión del montaje.

NOTICE

To clean your furniture, use a dry or wet cloth, and do not use chemicals that may damage your product.

ASSEMBLY SYSTEM

The products' assembly system works according to the increasing order of the indicated numbers. For example: 01, 02, 03, 04 ... to the end of the assembly.

Requisitos para montagem
Requisitor para la montaje
Assembly Requirements

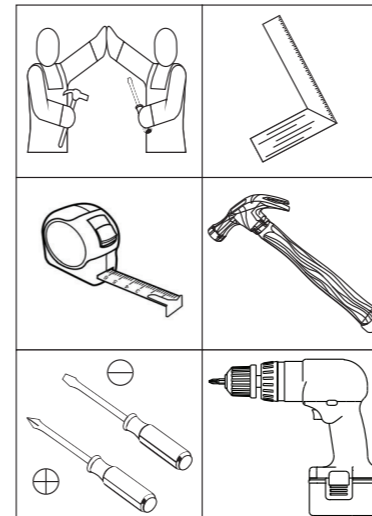

Imagens meramente ilustrativas
Imágenes meramente ilustrativas
Images for illustration only

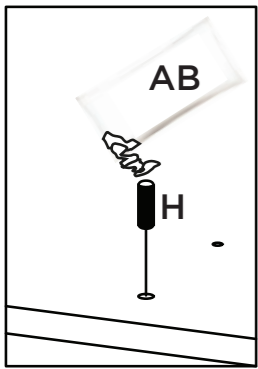
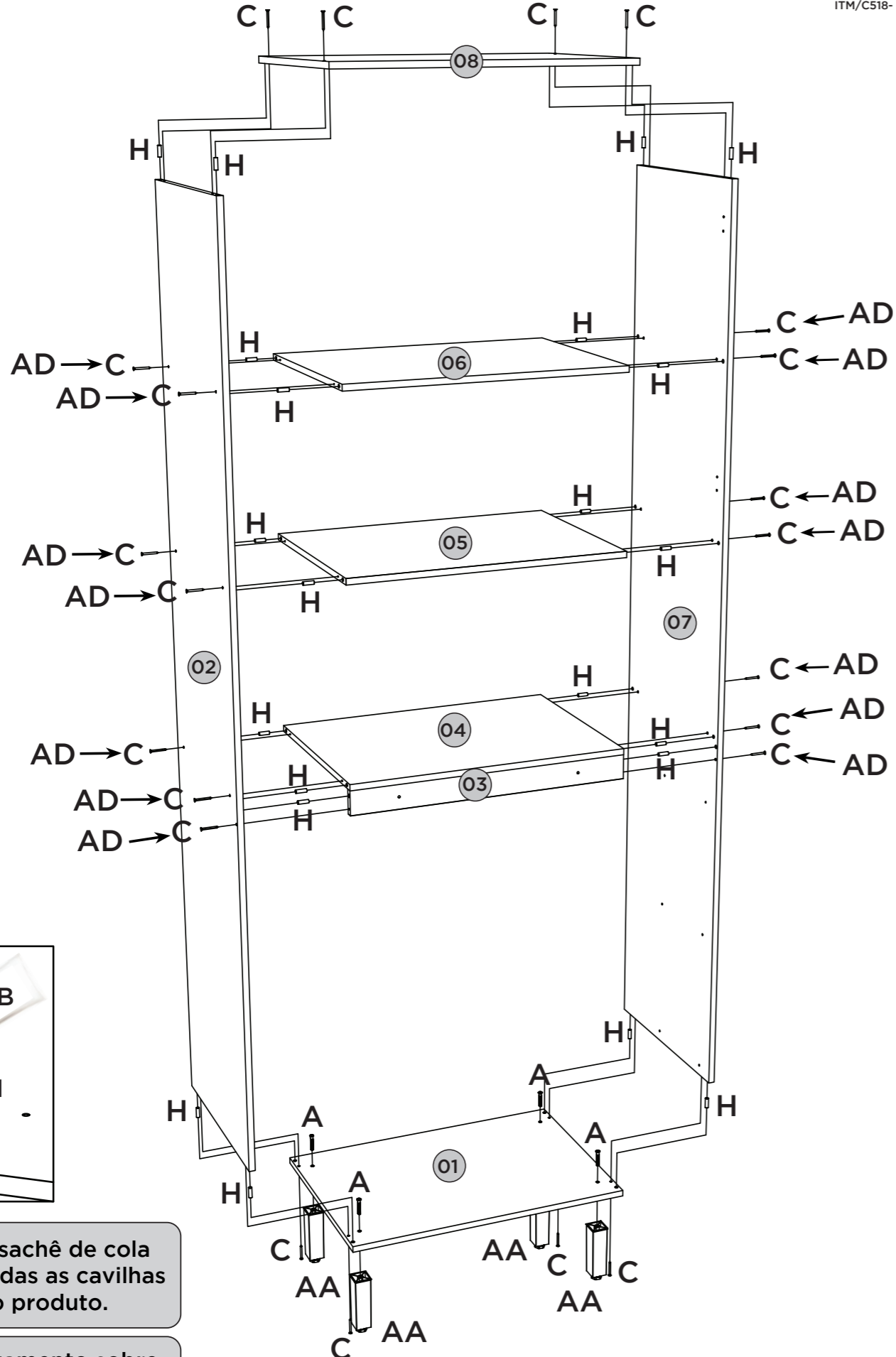

- Utilizar o sachê de cola (AB) em todas as cavilhas (H) do produto.
- Con el pegamento sobre (AB) en todos los pernos (H) producto.
- Use the glue sachet (AB) on all the pegs (H) of the product.

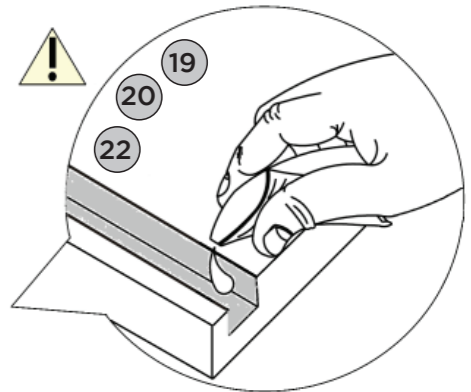
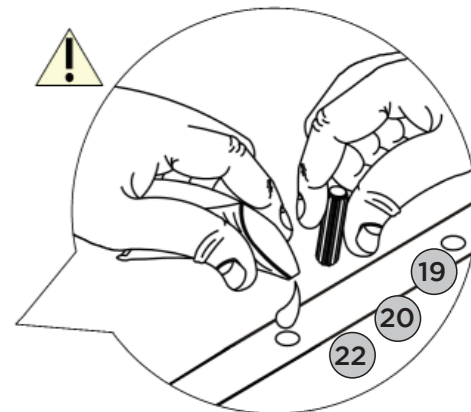
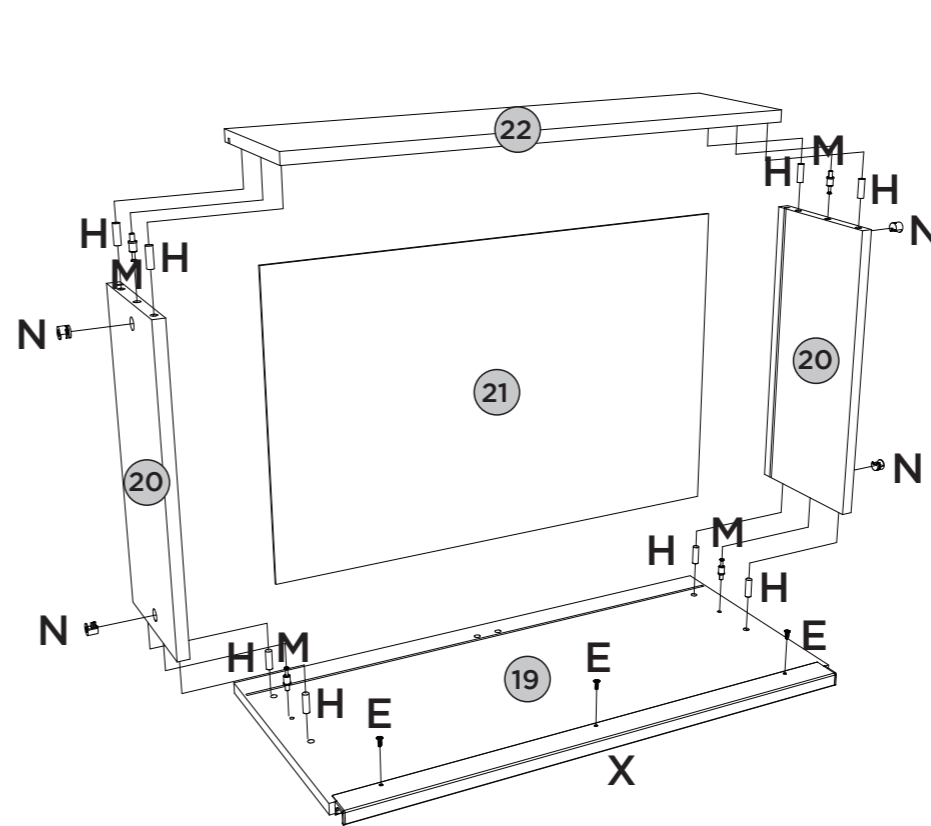

- Video: Dicas para fixar o Minifix
- Video: Consejos para arreglar Minifix
- Video: Tips for Fixing Minifix

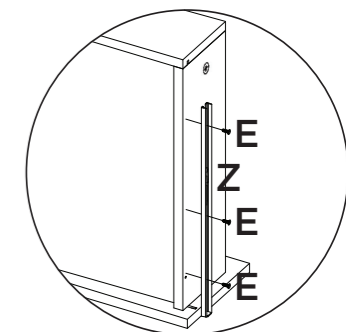
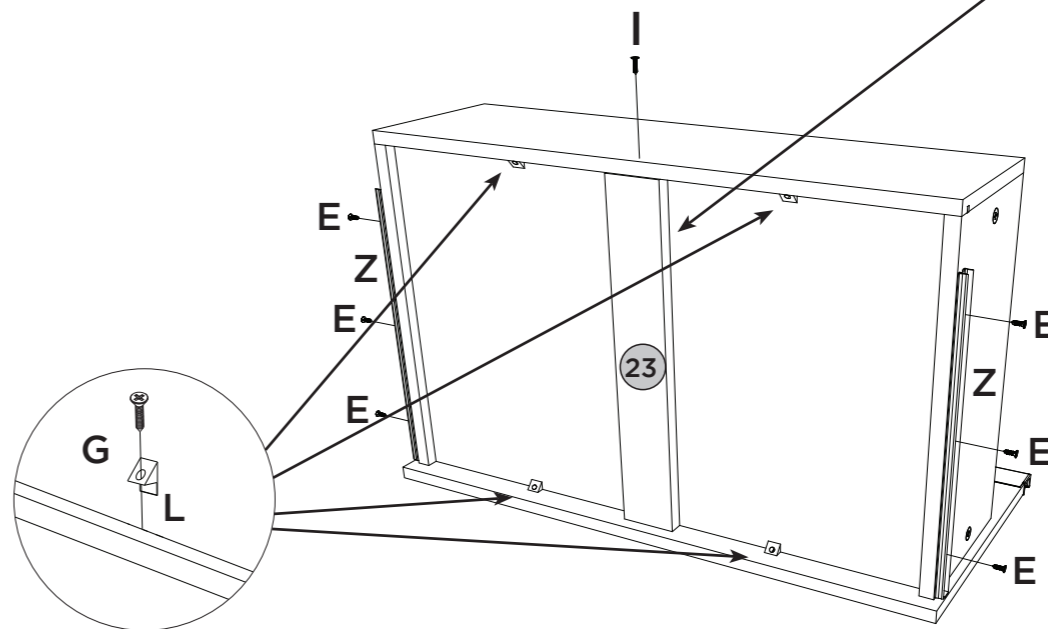
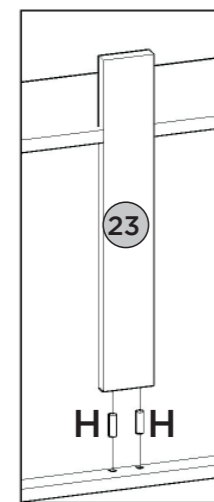

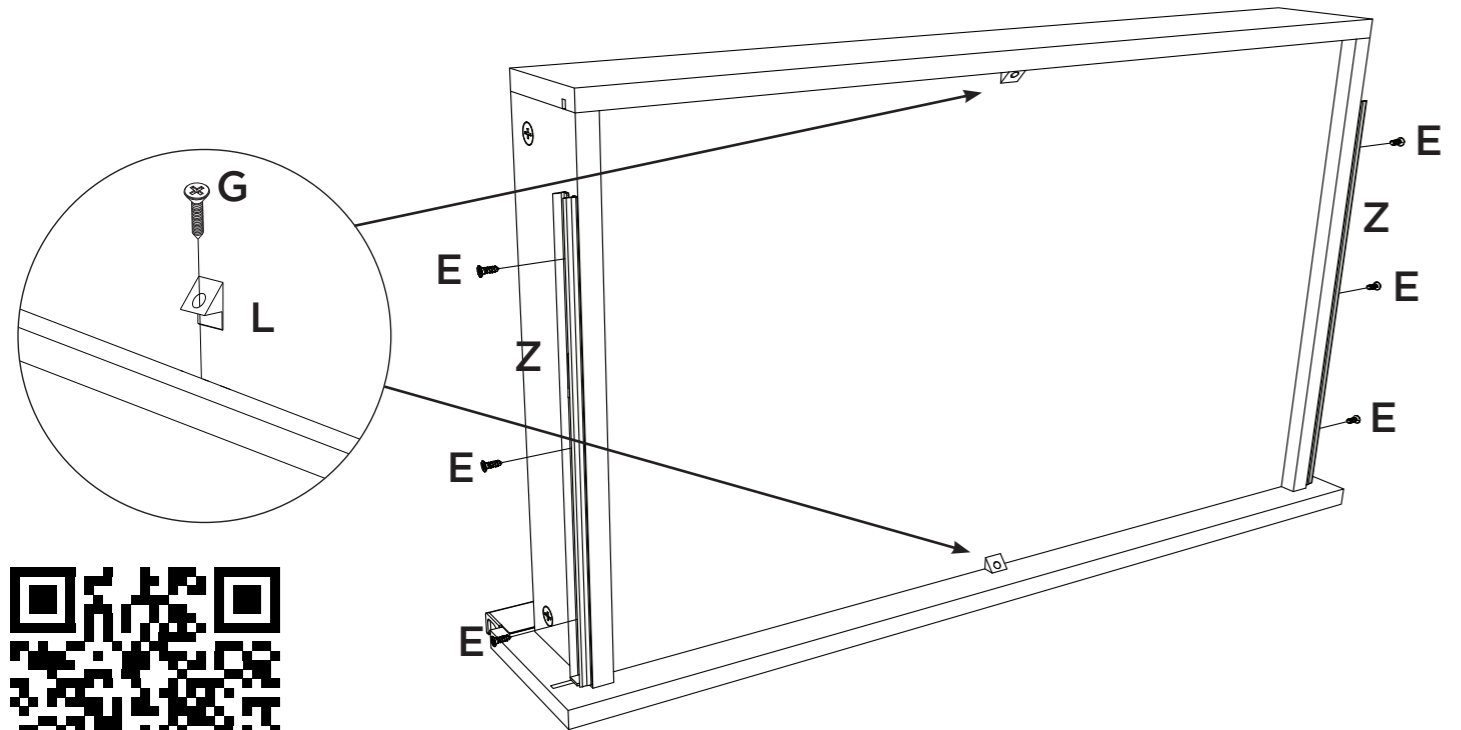
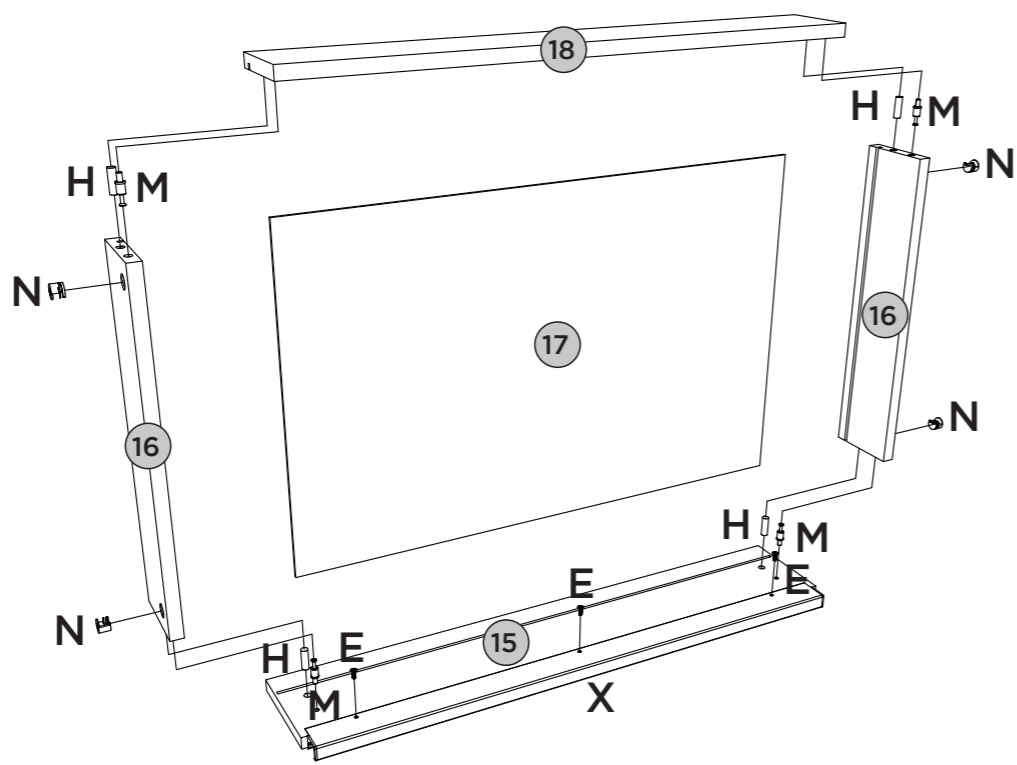
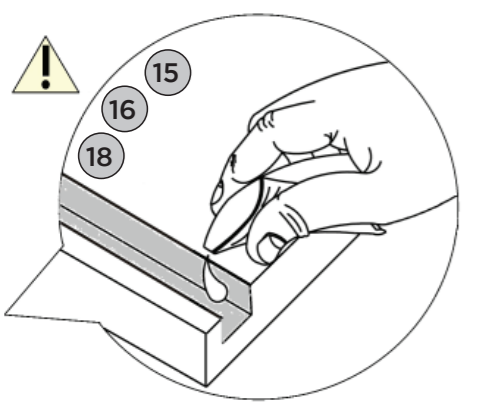
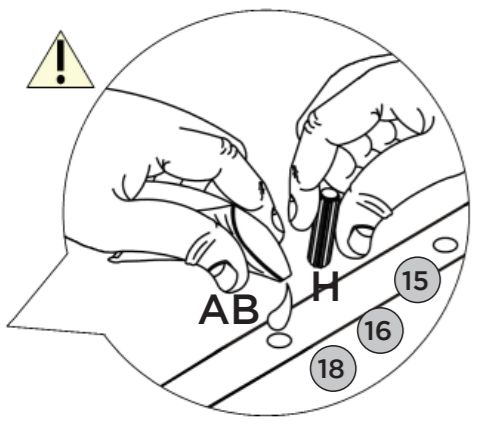

- Vídeo: Dicas para fixar a Corrediça
- Video: Consejos para arreglar la diapositiva
- Video: Tips for Fixing the Slide

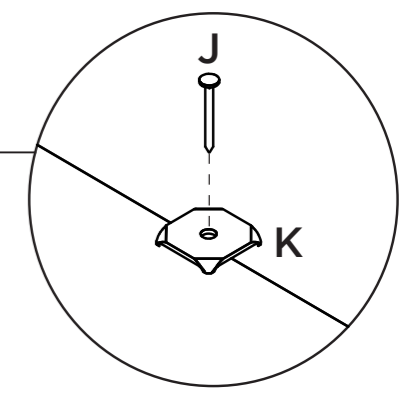
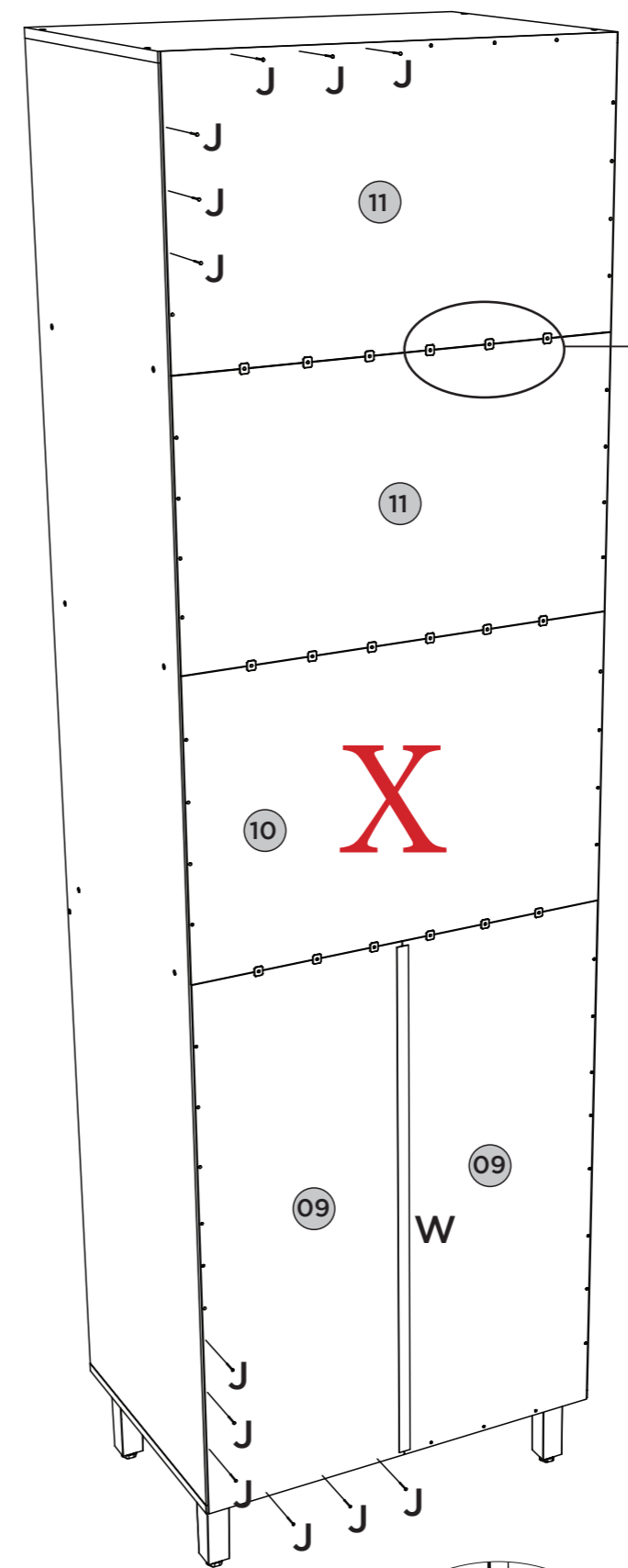
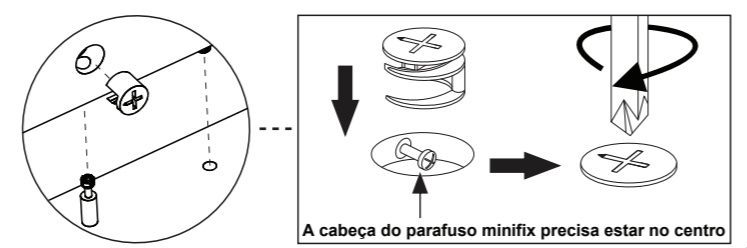

ATENÇÃO: Por questão de segurança, recomendamos a não utilização do Fundo (10) caso o espaço seja utilizado por forno elétrico ou forno embutido, dessa forma, haverá melhor propagação do calor, evitando danos em seu móvel.

ADVERTENCIA: Por razones de seguridad, se recomienda no utilizar el Fondo (10) si el espacio es utilizado por horno eléctrico o una función de horno, de esta manera no será mejor propagación del calor, evitando el daño a su móvil.

ATTENTION: For safety reasons, we recommend not using the Fund (10) if the space is used by an electric oven or built-in oven, in this way, there will be better propagation of the heat, avoiding damage to your furniture.

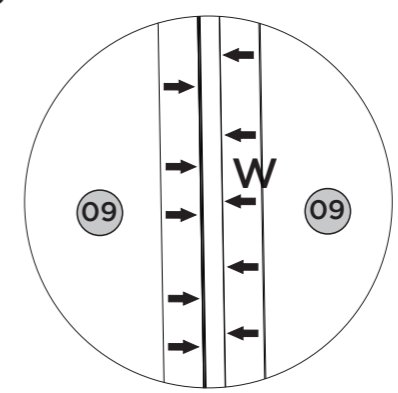

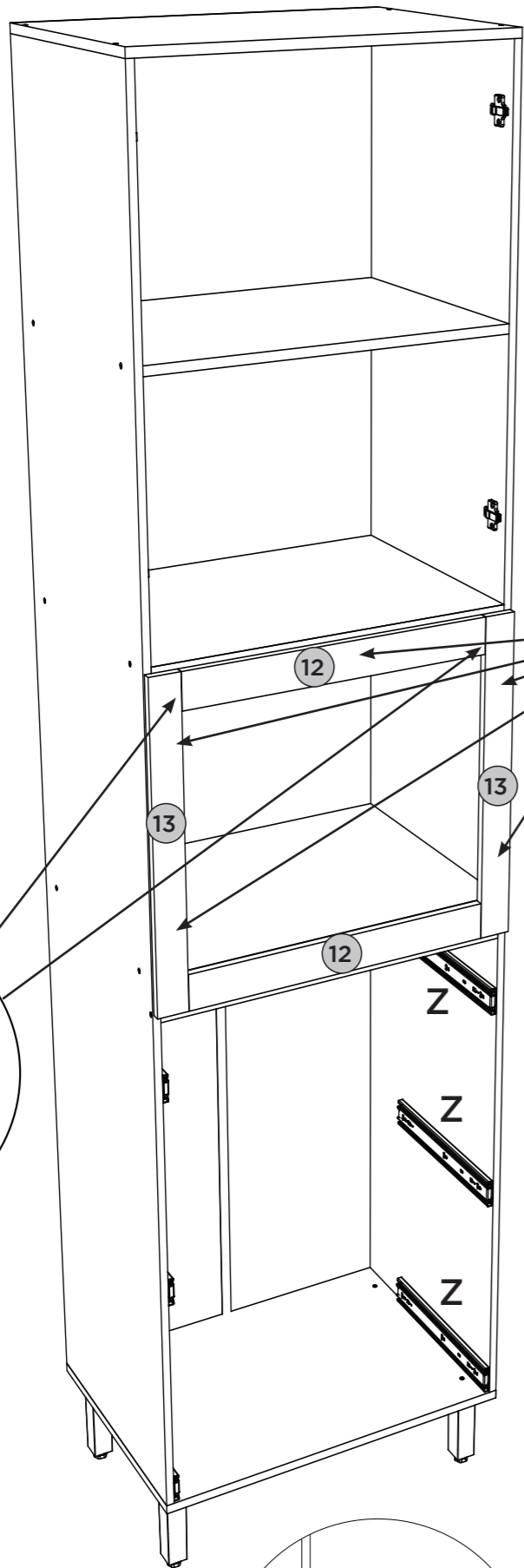

Conector de Montagem fixado Internamente

Conector de montaje fijado internamente

Mounting Connector fixed internally

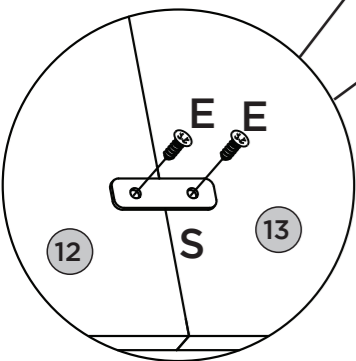
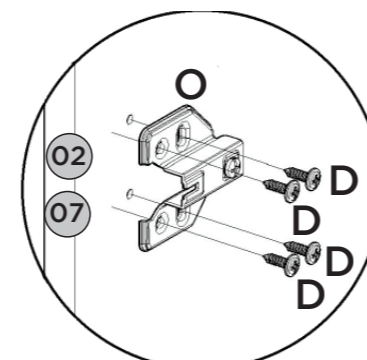
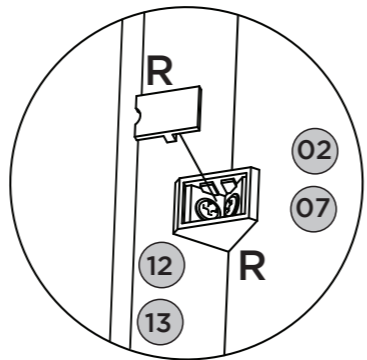
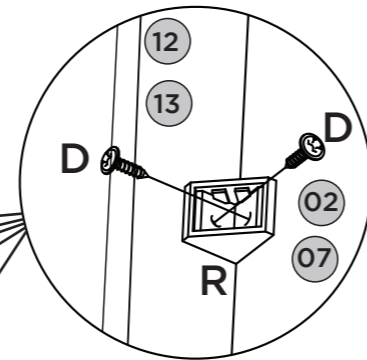

Suporte Metal fixado Internamente para unir as travessas

Soporte Metal fijado Internamente para unir los travesaños

Internally fixed metal bracket for joining the crossbars

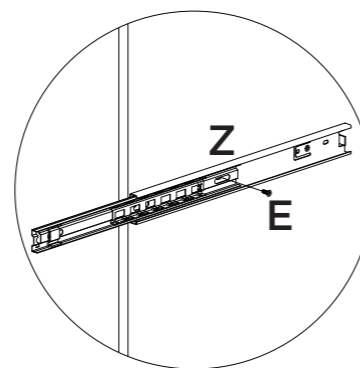
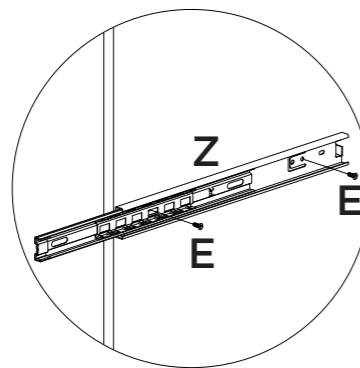

Opção Suspensa

Opción suspendida

Suspended Option

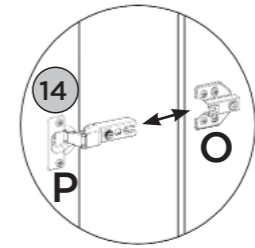
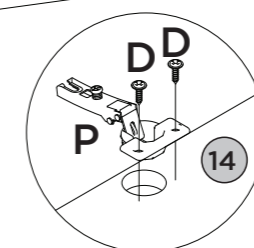
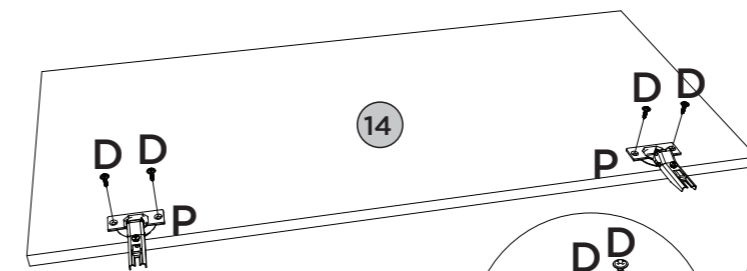
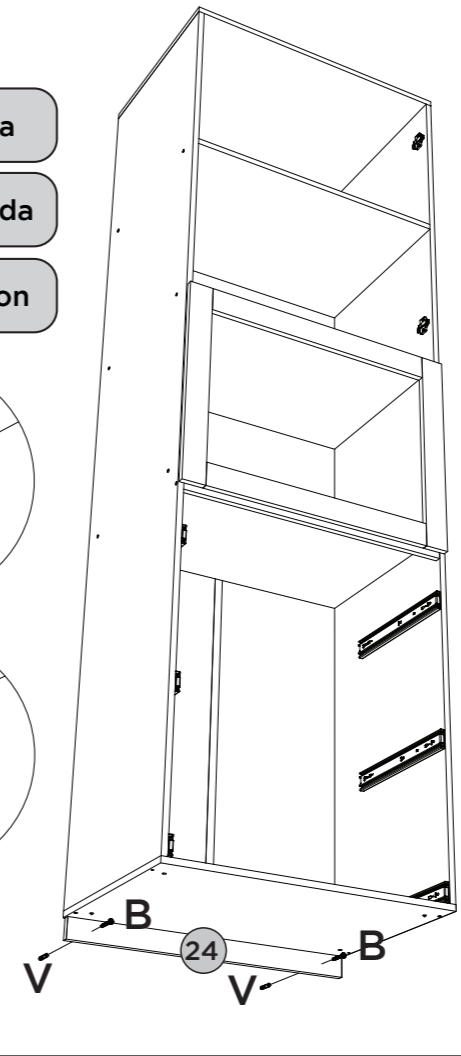
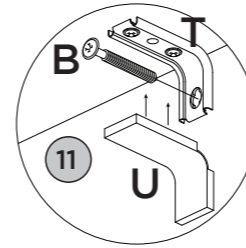
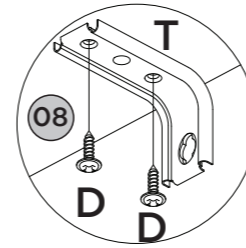

Vídeo: Instalar e regular Dobradiças

Video: Instale y ajuste las bisagras

Video: Install and adjust hinges



Para a desmontagem da correção siga a instrução ao lado.

Para el desmontaje seguimiento de diapositivas la instrucción siguiente a.

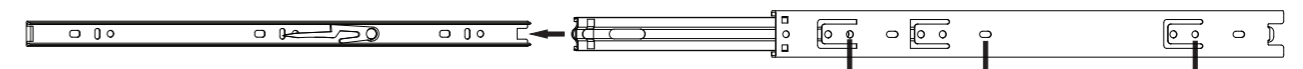
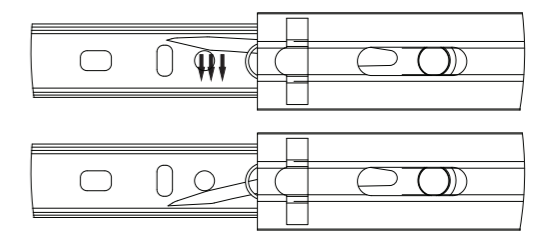

Fixar as correções nessas furações

Fijar las diapositivas de estos agujeros