

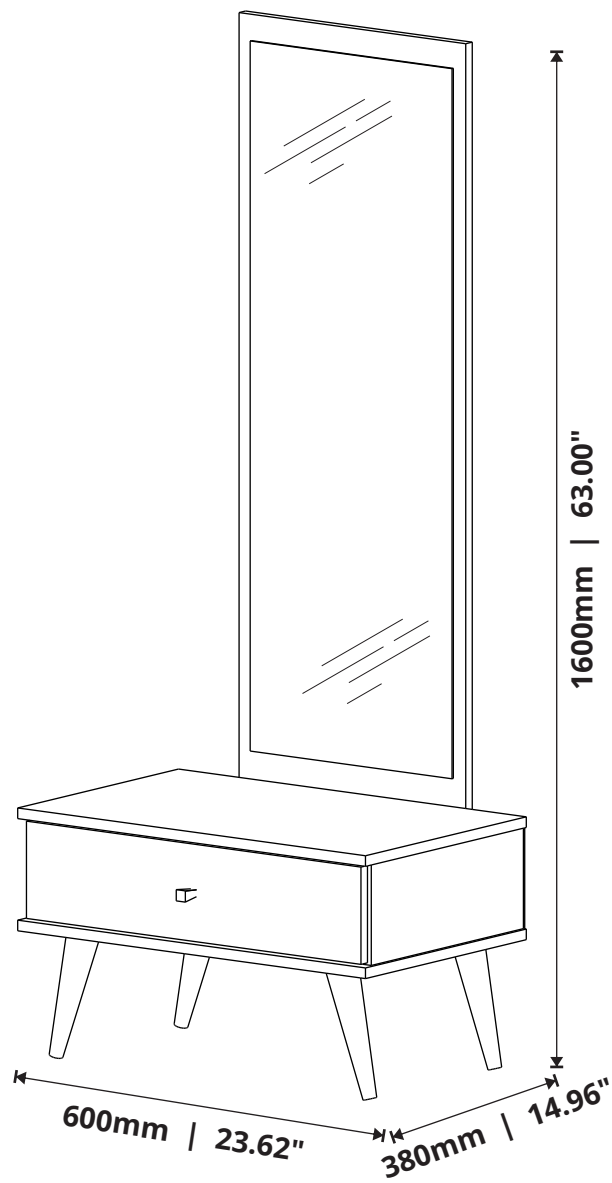

Toucador 7001
Dressing Table 7001
Tocador 7001



www.jbbechara.com.br
SAC +55 17 3272-9190
assistencia@jbbechara.com.br
export@jbbechara.com.br

ACESSÓRIOS

ACCESSORIES - ACCESORIOS

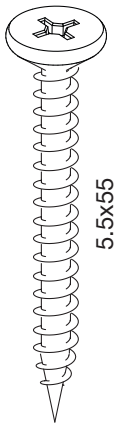

PARAFUSO
SCREW
TORNILLO

A
04 x

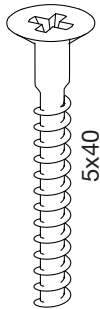

PARAFUSO
SCREW
TORNILLO

B
04 x



PARAFUSO
SCREW
TORNILLO

C
01 x



PARAFUSO
SCREW
TORNILLO

D
08 x

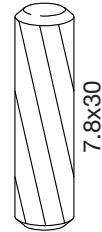

CAVILHA
DOWEL
TARUGO

E
16 x



PINO MINIFIX
MINIFIX BOLT
TORNILLO MINIFIX

F
08 x

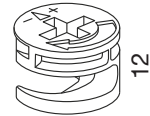

CASTANHA MINIFIX
MINIFIX CAM
CAJA MINIFIX

G
08x

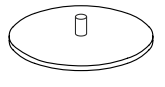

TAMPA MINIFIX
MINIFIX CAP
TAPA MINIFIX

H
08x



PREGO
NAIL
CLAVO

I
20 x

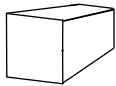

PUXADOR
HANDLE
MANIJA

J
01x

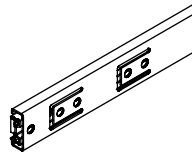

CORREDIÇA TELESCÓPICA
TELESCÓPIC SLIDERS
CORREDERA TELESCÓPICA

K
01x

CAPACIDADE DE CARGA

LOAD CAPACITY - CAPACIDAD DE CARGA

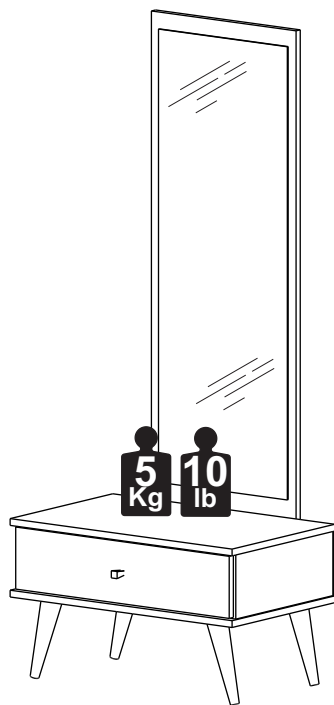

A CAPACIDADE DE CARGA INDICADA É DISTRIBUÍDA NAS ÁREAS DEMONSTRADAS.

THE INDICATED LOAD CAPACITY IS DISTRIBUTED IN THE SHOWN AREAS.

LA CAPACIDAD DE CARGA INDICADA ES DISTRIBUIDA EN ZONAS DEMONSTRADAS.

CONSERVANDO O SEU MÓVEL / MAINTAINING YOUR FURNITURE / MANTENIENDO SU MOBILIARIO

LIMPEZA DO MÓVEL / CLEANING THE FURNITURE / LIMPIANDO SU MOBILIARIO

Na remoção da poeira utilizar flanela limpa e levemente umedecida, em seguida flanela seca para remoção da umidade.
To remove dust use a clean flannel slightly moistened and afterwards a dry flannel to remove the humidity.

Para limpar el polvo utiliza una franela limpia y humedecida y después una franela seca para quitar la humedad.

RECOMENDAÇÕES DE USO / USE RECOMMENDATIONS / RECOMENDACIONES DE USO

Não expor a luz solar e locais úmidos.
Do not expose to sun light and humid places.
No exponga a la luz solar y lugares húmedos.

Não encostar o móvel na parede para evitar transmissão de umidade.
Do not lean the furniture in the wall to avoid humidity transmission.
No apoye el mobiliario en la pared evitar la transmisión de humedad.

Não movimentar o móvel.
Do not move your furniture.
No mueva su mobiliario.

PEÇAS

PIECES - PIEZAS

PORTUGUÊS

- 01- Base
- 02- Lateral Esquerda/Direita
- 03- Tampo
- 04- Fundo com Espelho
- 05- Frente de Gaveta
- 06- Lateral de Gaveta
- 07- Contra Fundo de Gaveta
- 08- Fundo de Gaveta
- 09- Fundo Traseiro
- 10- Pé

ENGLISH

- 01- Base
- 02- Left/Right Side
- 03- Top
- 04- Back Panel w/ Mirror
- 05- Drawer Front
- 06- Drawer Side
- 07- Drawer Back
- 08- Drawer Bottom
- 09- Back Panel
- 10- Leg

ESPAÑOL

- 01- Base
- 02- Lado Izquierdo/Derecho
- 03- Tapa
- 04- Fondo con Espejo
- 05- Frente del Cajón
- 06- Lado del Cajón
- 07- Trazera del Cajón
- 08- Fondo del Cajón
- 09- Fondo Trasero
- 10- Pie

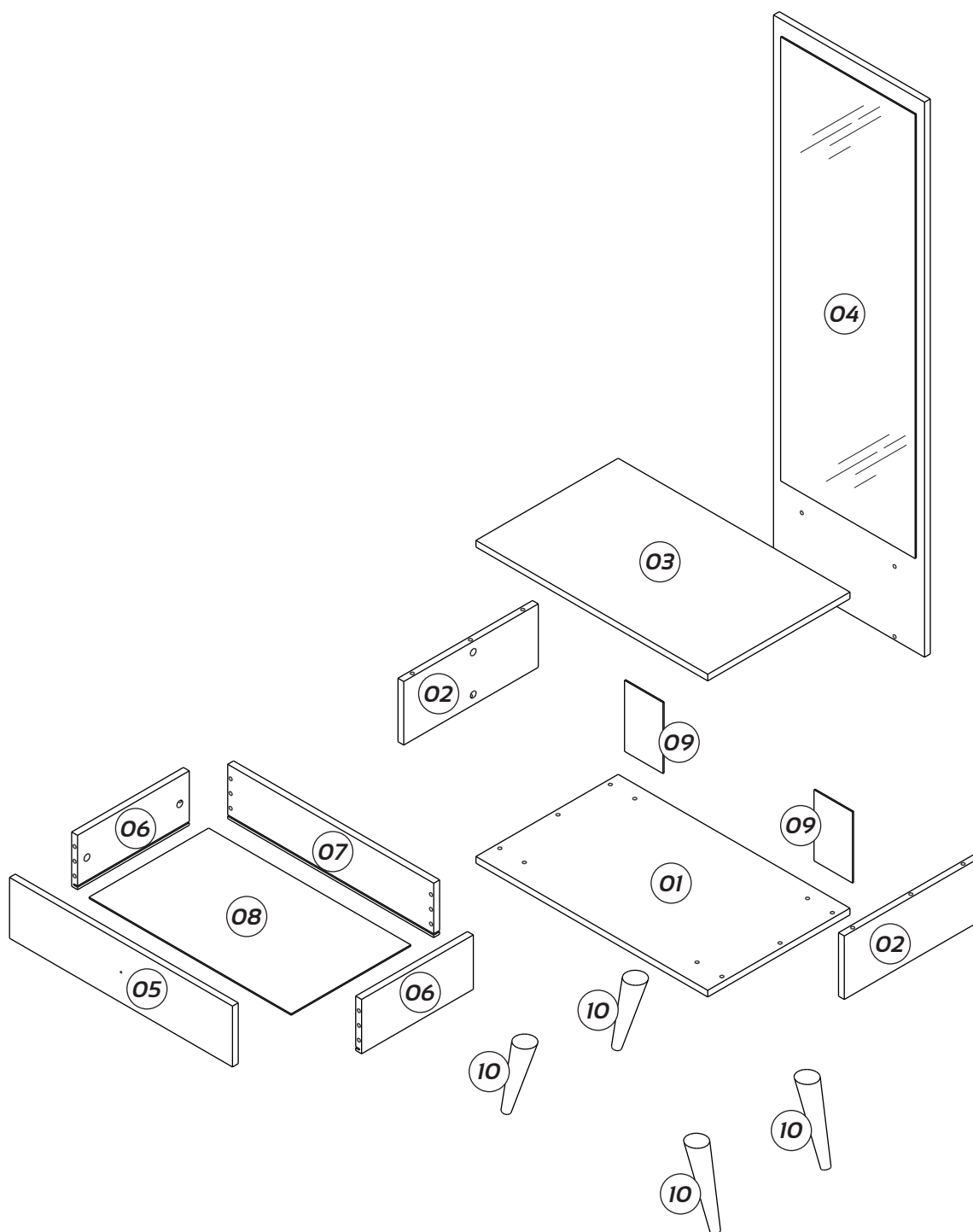

PRÉ-MONTAGEM

PRE ASSEMBLY - PRÉ-MONTAJE

IMPORTANTE

ATTENTION - IMPORTANTE

A MONTAGEM DEVE SER REALIZADA POR UM PROFISSIONAL DE MONTAGEM.
ASSEMBLY MUST BE CARRIED OUT BY AN ASSEMBLY PROFESSIONAL.
EL MONTAJE DEBE SER HECHO POR UN MONTADOR DE MUEBLES.

1

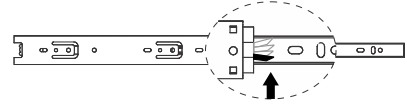

Para separar a corredeira é necessário movimentar o aplico de plástico que encontra-se no verso da mesma. Mova o aplico para cima, segure e puxe a parte removível da corredeira.

To separate the slider, it is necessary to move the plastic insert on the it's back. Move the applique up, hold and pull the removable part of the slider.

Para separar la corredera es necesario mover la pieza de plástico que se encuentra en la parte posterior de la misma. Mover la pieza de plástico, mantenga y tire de la parte móvil de la corredera.

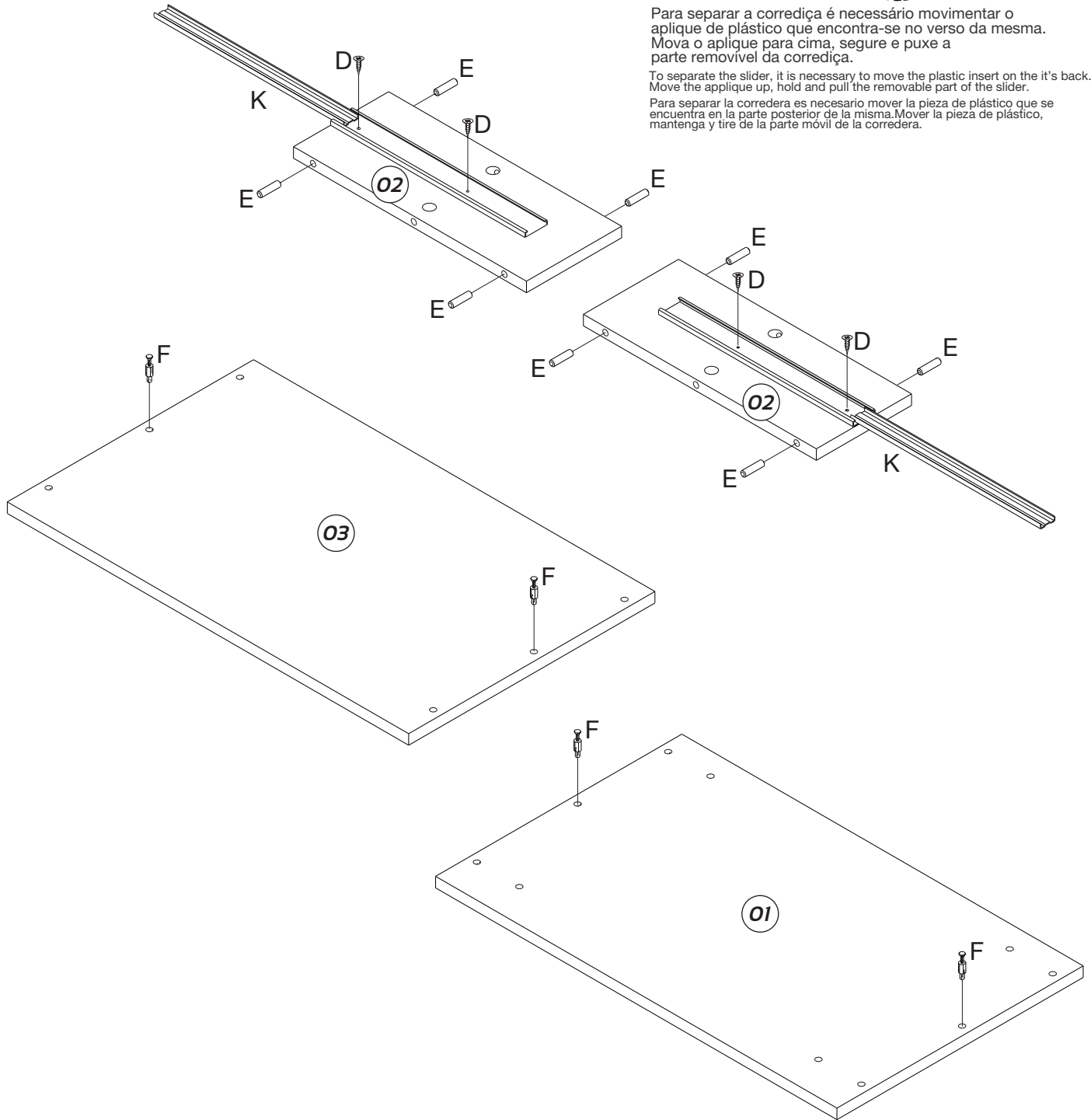

INSTRUÇÕES

INSTRUCTIONS - INSTRUCCIONES

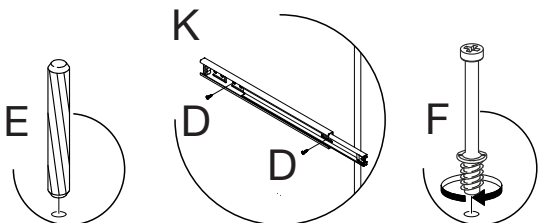

MONTAGEM

ASSEMBLY - MONTAJE

1

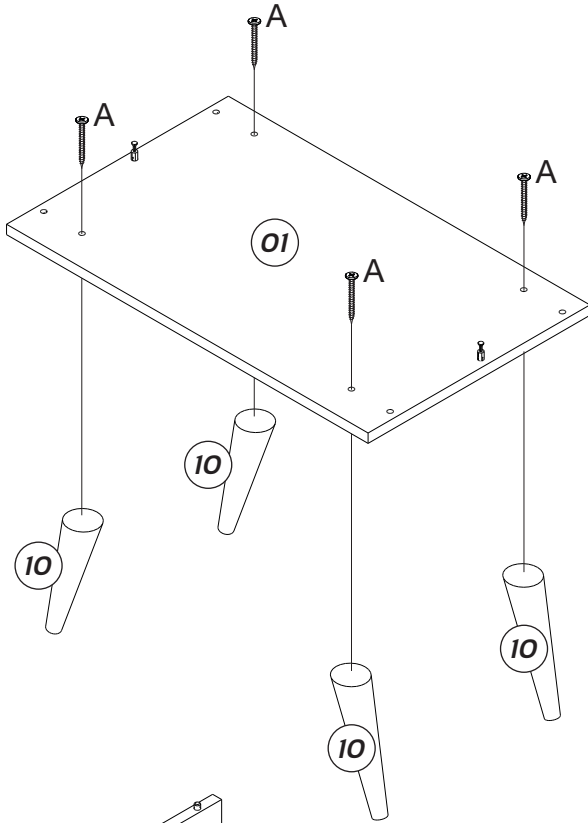

2

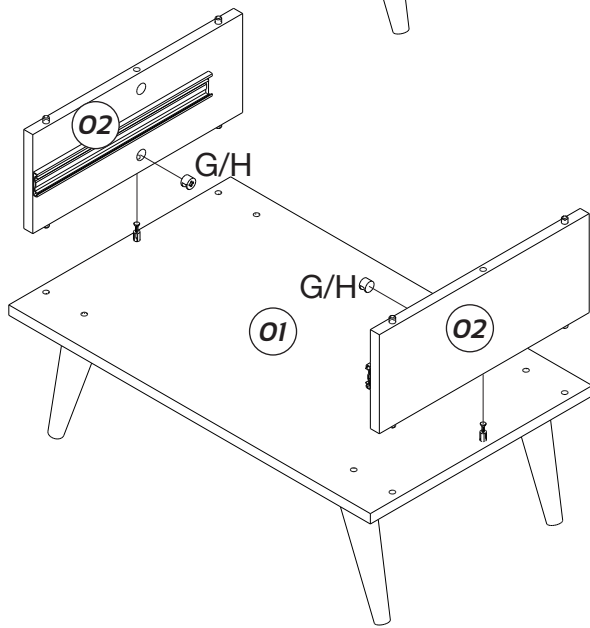

3

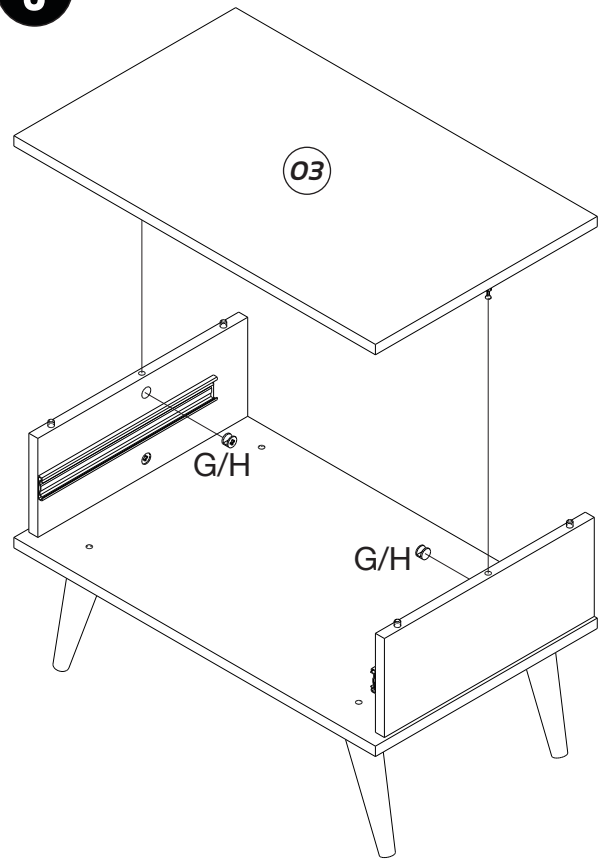

INSTRUÇÕES

INSTRUCTIONS - INSTRUCCIONES

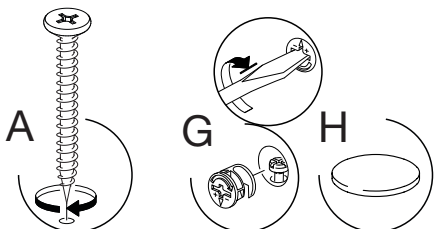

MONTAGEM

ASSEMBLY - MONTAJE

4

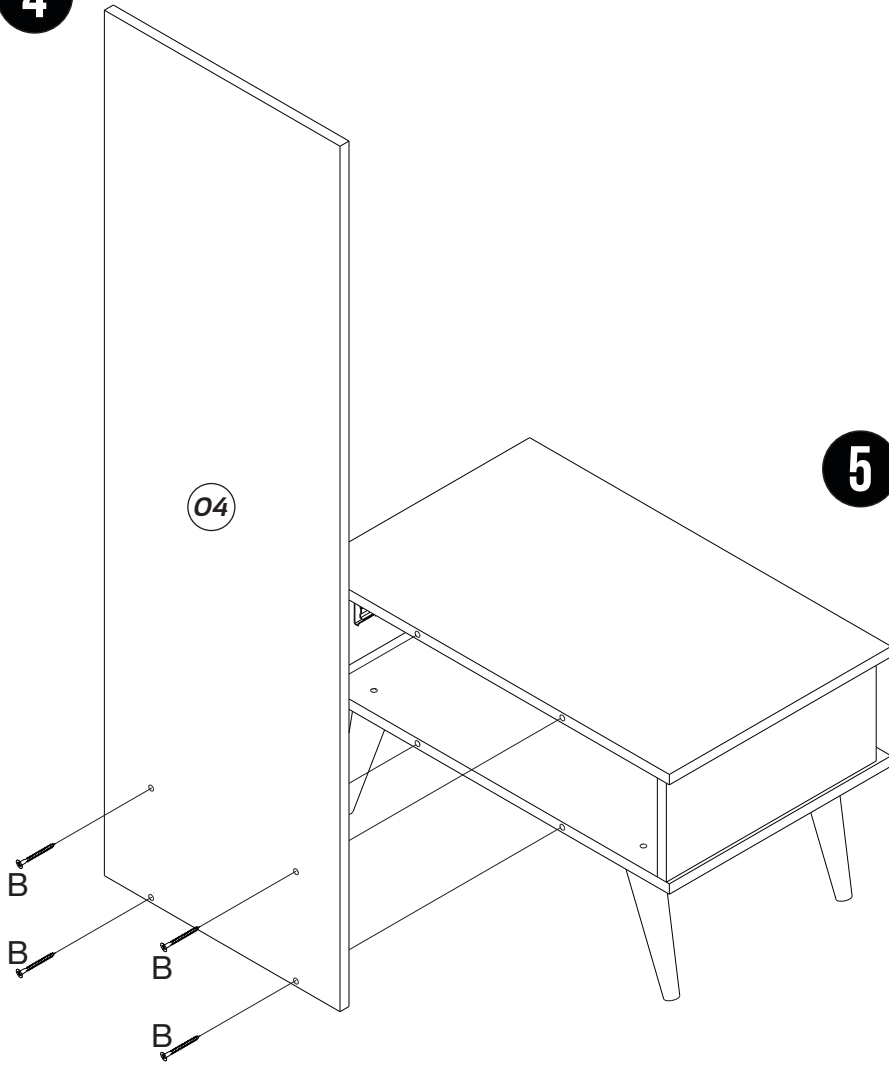

5

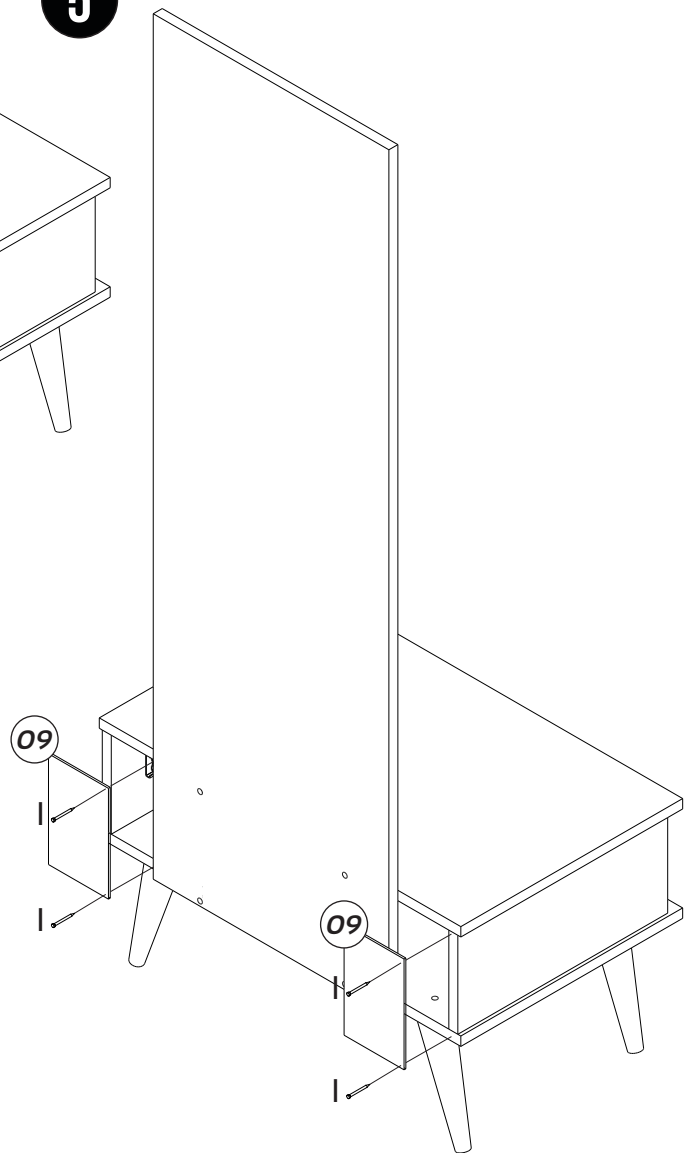

INSTRUÇÕES

INSTRUCTIONS - INSTRUCCIONES

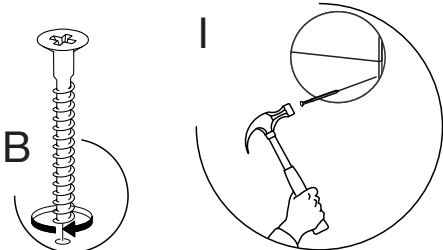

MONTAGEM

ASSEMBLY - MONTAJE

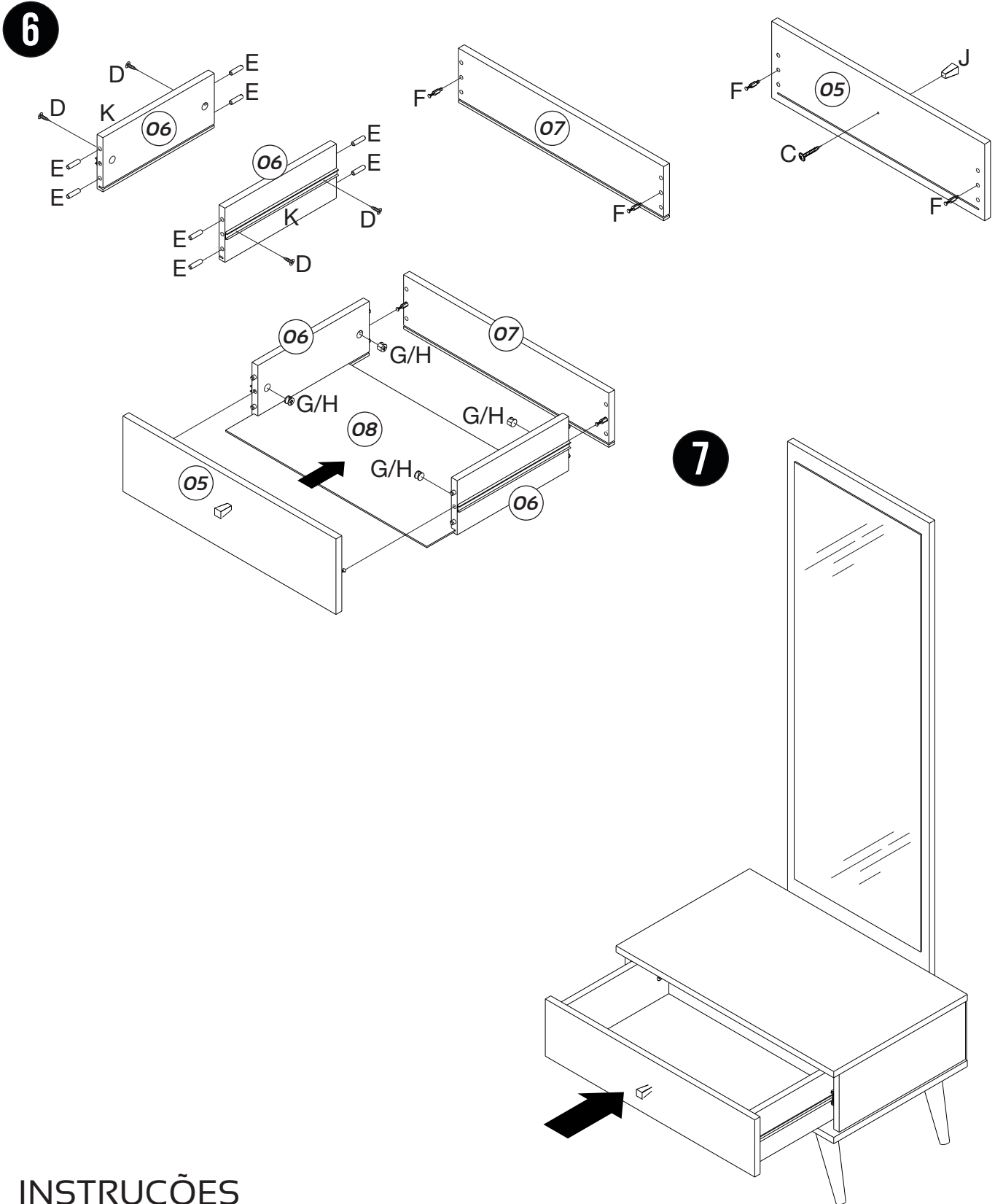

INSTRUÇÕES

INSTRUCTIONS - INSTRUCCIONES

