

INSTRUÇÕES DE MONTAGEM

INSTRUCCIONES DE MONTAJE
ASSEMBLY INSTRUCTIONS

Mesa Alicia 1300mm Com Vidro

SC19-129 Off White/Nature

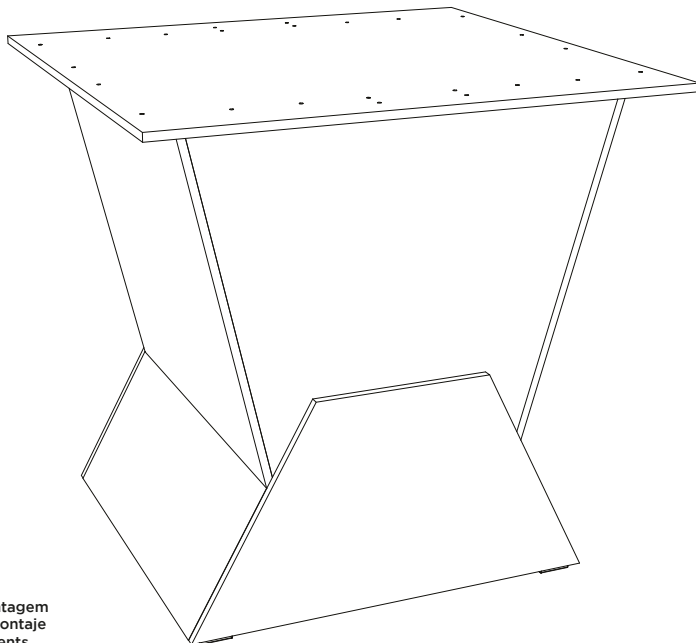

Requisitos para montagem
Requisitos para la montaje
Assembly Requirements

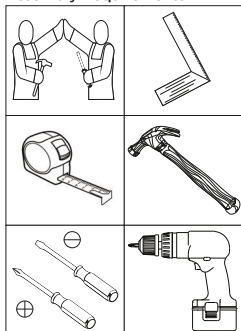

Imagens meramente ilustrativas,
não acompanha o produto.
Imágenes ilustrativas, no incluidas
con el producto.
Illustrative images, not included
with the product.

ASSISTÊNCIA TÉCNICA

Para solicitação de Assistência Técnica você consumidor deverá entrar em contato com o Lojista o qual você realizou a compra deste produto e solicitar a assistência técnica das peças avariadas. A garantia abrange todas as peças, partes e componentes que eventualmente venham apresentar defeito de fabricação no prazo de 03 (três) meses, contando a partir da entrega do produto ao consumidor, mediante nota fiscal de compra.

AVISO

Para limpeza de seu móvel, use uma flanela seca ou umedecida, e não utilize produtos químicos que possam danificar seu produto.

SISTEMA DE MONTAGEM

O sistema de montagem dos produtos, funciona de acordo com a ordem crescente dos números indicados no desenho. Ex: 01, 02, 03, 04... até a conclusão da montagem.

ADVERTENCIA

Para limpieza de su móvil, use una flanela seca o húmeda, y no utilice productos químicos que puedan dañar su producto.

SISTEMA DE MONTAJE

El sistema de montaje de los productos funciona de acuerdo con el orden creciente de los números indicados en el dibujo. Ej.: 01, 02, 03, 04... hasta la conclusión del montaje.

NOTICE

To clean your furniture, use a dry or wet cloth, and do not use chemicals that may damage your product.

ASSEMBLY SYSTEM

The products' assembly system works according to the increasing order of the indicated numbers. For example: 01, 02, 03, 04 ... to the end of the assembly.

ACESSÓRIOS | ACCESORIOS | ACCESSORIES

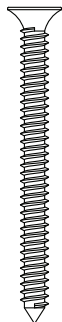
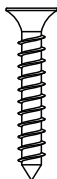
A **x8**B **x36**C **x48**

D

**x4**

E

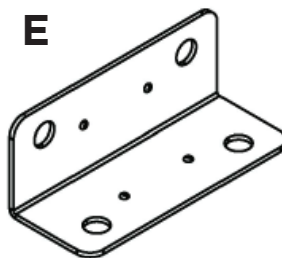
**x12**

ACESSÓRIOS | ACCESORIOS | ACCESSORIES

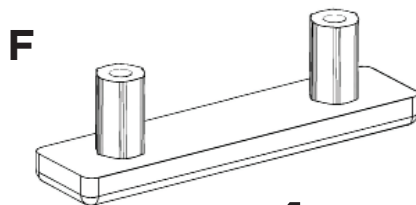

x4

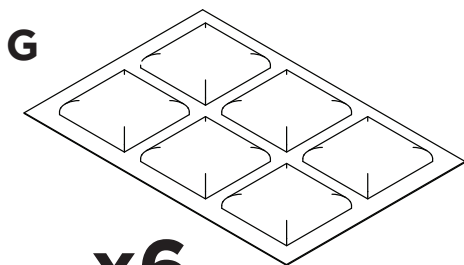

x6

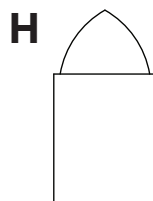

x2

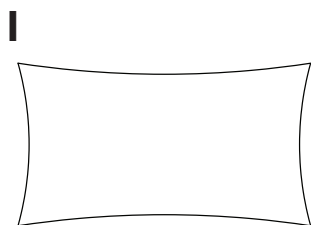

x1

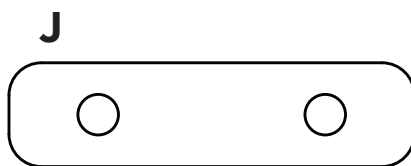

x4

LISTA DE PEÇAS | LISTA DE PIEZAS | LIST OF PIECES

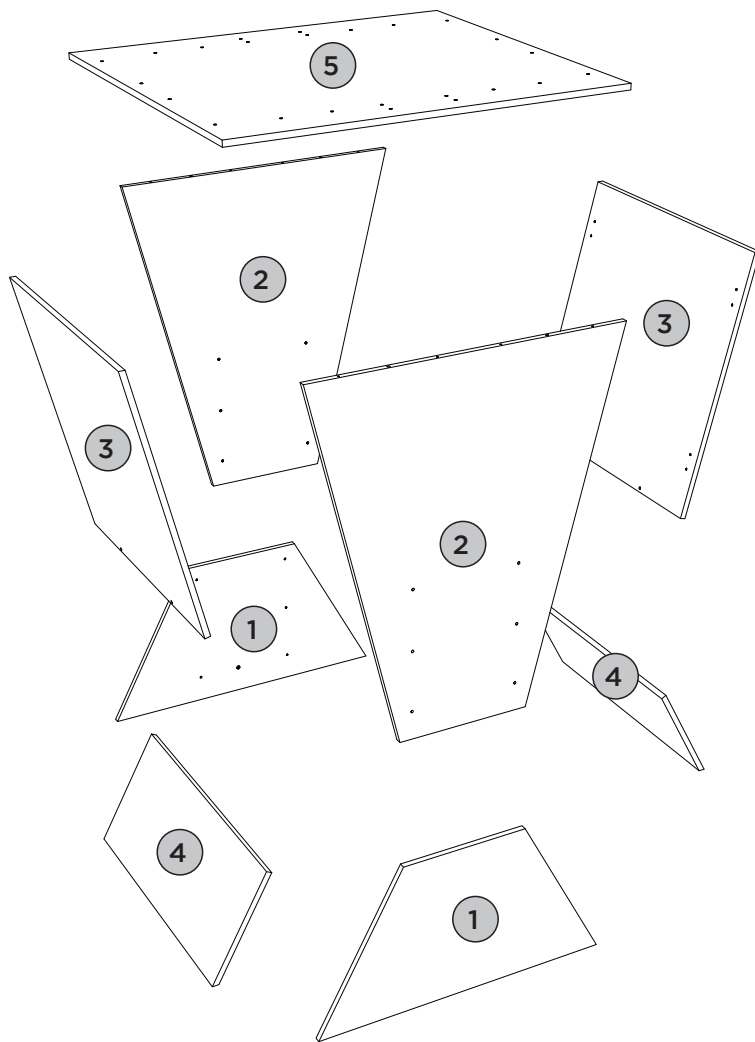





Item	Caixa Caja Box	Qty Ctd Qty	Descrição Descripción Description	Dimensões (mm) Dimensiones (mm) Dimensions (mm)		
				Comprimento Largo Length	Largura Ancho Width	Espessura Grosor Thickness
1	1/1	02	APLIQUE MENOR APLICAR MÁS PEQUEÑO APPLY SMALLER	650	350	12
2	1/1	02	LATERAL MAIOR LADO MÁS GRANDE BIGGER SIDE	754	650	12
3	1/1	02	LATERAL CHANFRADA LADO BISELADO CHAMFERED SIDE	570	556	12
4	1/1	02	LATERAL MENOR CHANFRADA LADO MENOR BISELADO BEVELED MINOR SIDE	556	252	12
5	1/1	01	TAMPO ESTRUTURAL PARTE SUPERIOR ESTRUTURAL STRUCTURAL TOP	800	700	12

PEÇAS REQUERIDAS

1	APLIQUE MENOR	x2
2	LATERAL MAIOR	x2
3	LATERAL CHANFRADA	x2

ACESSÓRIOS REQUERIDOS

C		16
D		04
E		08
F		04
I		

FERRAMENTAS NECESSÁRIAS

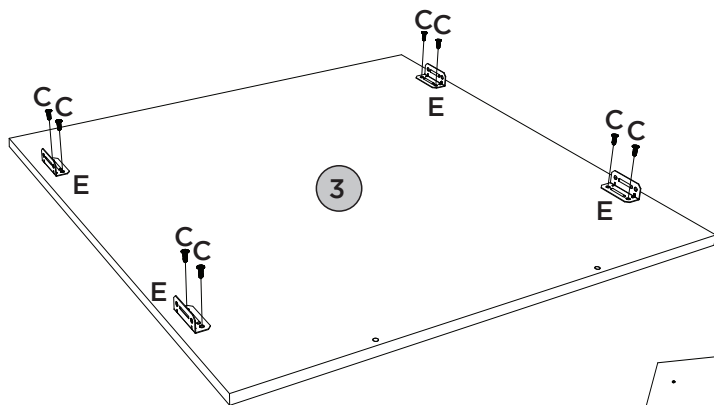
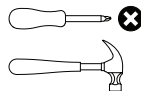

Peça (3) com pré furações para cantoneiras (E).
Pieza (3) con pretaladrado para ángulos (E).
Piece (3) with pre-drilling for angles (E).

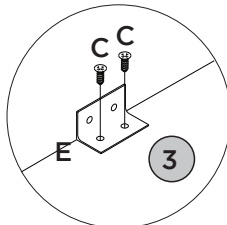
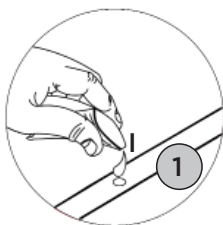
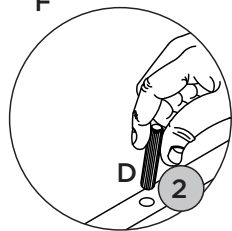
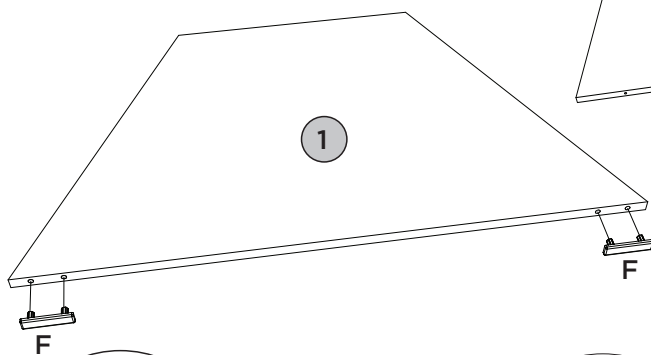

Colocar cola (I) nas furações para as sapatas (F).

Ponga pegamento (I) en los agujeros para el zapatos (F).

Put glue (I) in the holes for the shoes (F).

PASSO 2

ITM/S410-

PEÇAS REQUERIDAS

1	LATERAL CHANFRADA	x2
2	LATERAL MAIOR	x2

ACESSÓRIOS REQUERIDOS

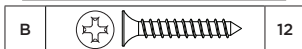

FERRAMENTAS NECESSÁRIAS

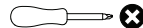

2x

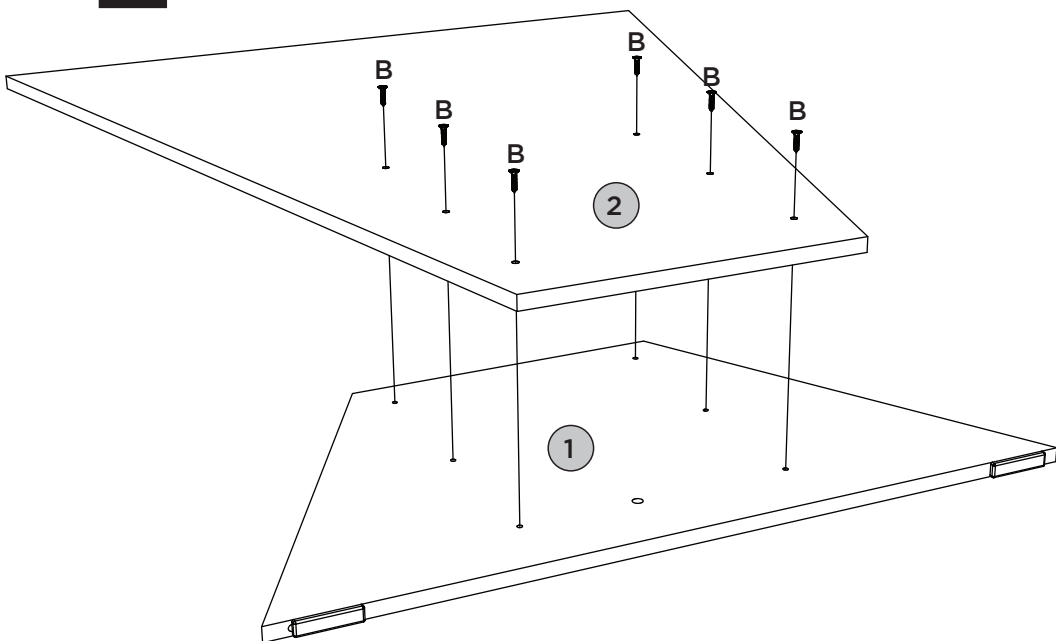

PASSO 3

ITM/S410-

PEÇAS REQUERIDAS

2	LATERAL MAIOR	x2
3	LATERAL CHANFRADA	x2

ACESSÓRIOS REQUERIDOS

C		16
---	--	----

FERRAMENTAS NECESSÁRIAS

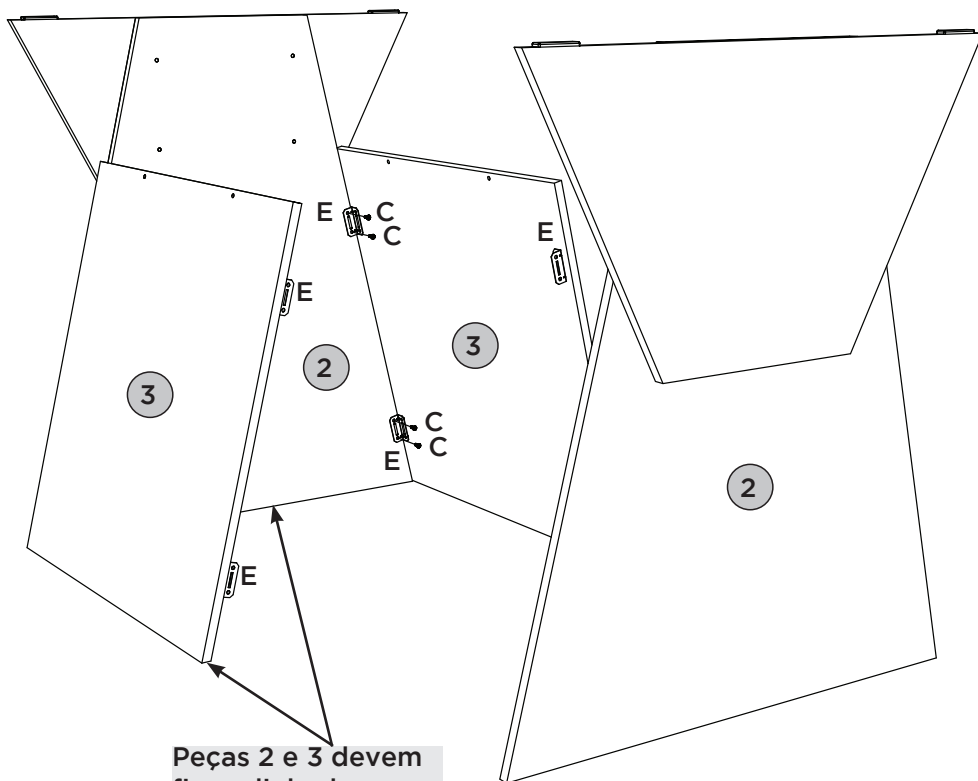
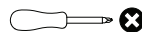

Peças 2 e 3 devem ficar alinhadas.

Las piezas 2 y 3 deben alinearse.

Pieces 2 and 3 should line up.

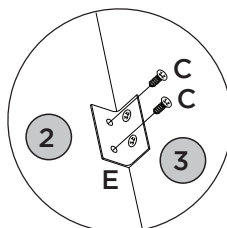



PASSO 4

ITM/S410-

PEÇAS REQUERIDAS

4	LATERAL MENOR CHANFRADA	x2
---	----------------------------	----

ACESSÓRIOS REQUERIDOS

B		04
C		16
E		04

FERRAMENTAS NECESSÁRIAS

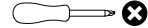

Etapa 1 Escenário 1 Phases 1

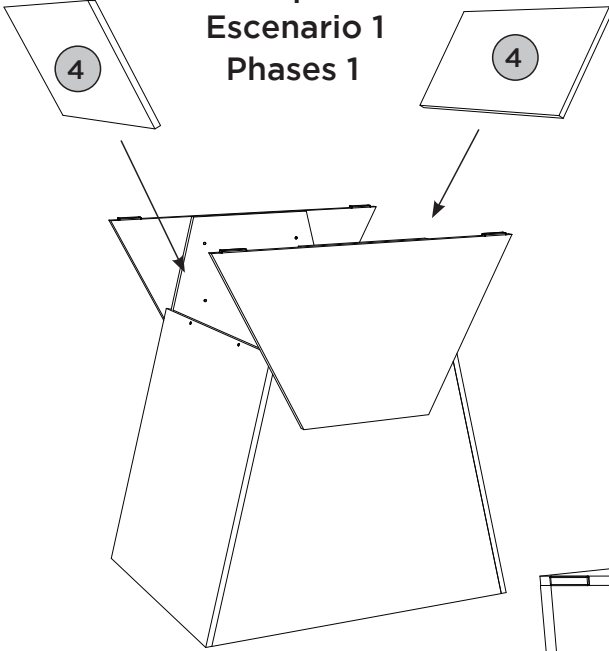

Etapa 2 Escenário 2 Phases 2

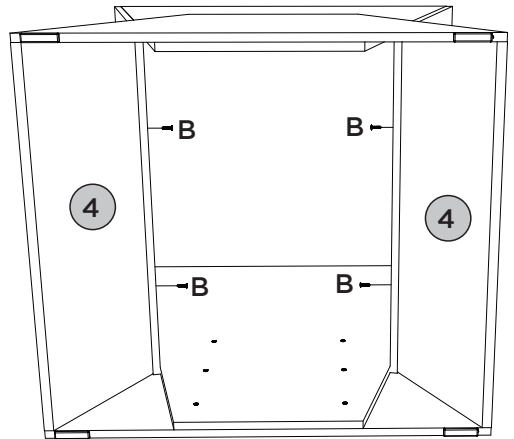

Etapa 3 Escenário 3 Phases 3

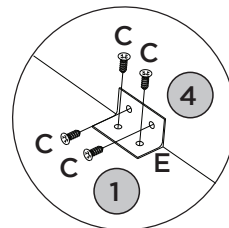
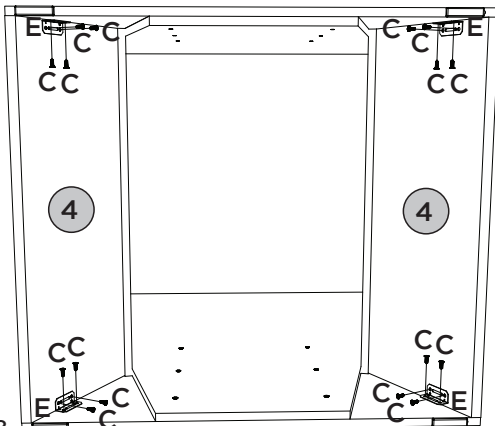

PASSO 5

ITM/S410-

PEÇAS REQUERIDAS

ACESSÓRIOS REQUERIDOS

FERRAMENTAS NECESSÁRIAS

5	TAMPO ESTRUTURAL	x1
---	------------------	----

A		08
---	---	----

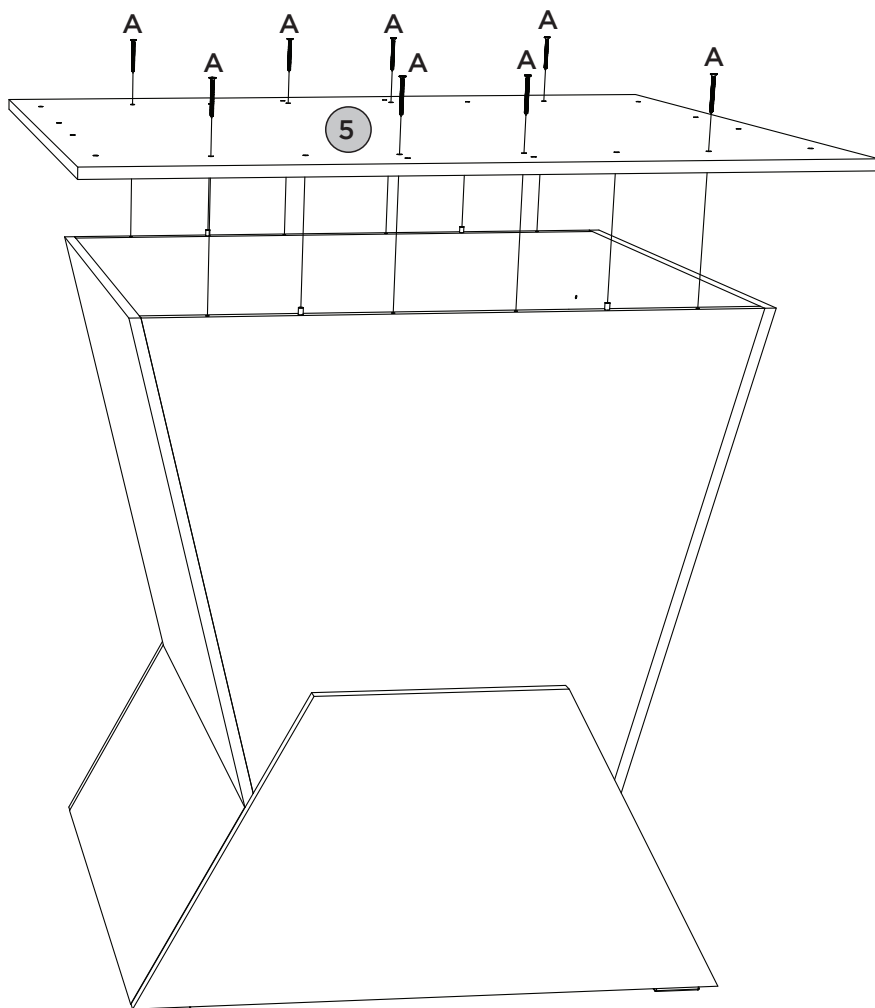
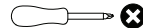



TAMPOS - VENDIDOS SEPARADAMENTE |
TOPS - SE VENDEN POR SEPARADO |
TOPS - SOLD SEPARATELY.

Opção de Montagem com o Tampo 1300x1300
canto reto com Vidro (S912-139)

Opción de montaje con la parte superior 1300x1300
esquina recta con vidrio (S912-139)

Mounting Option with the Top 1300x1300
straight corner with Glass (S912-139)

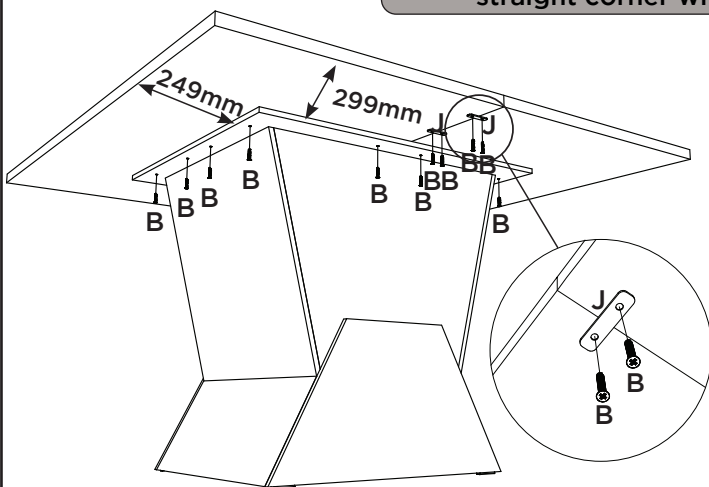

A pintura do Vidro
deve ficar virada
para baixo, depois
ajustá-lo sobre os
batentes de silicone
(G).

La pintura de vidrio
debe mirar ha-
cia abajo, luego
ajustarla sobre los
topes de silicona
(G).

The glass paint
should be
facing downwards,
then adjust it over
the silicone stops
(G).

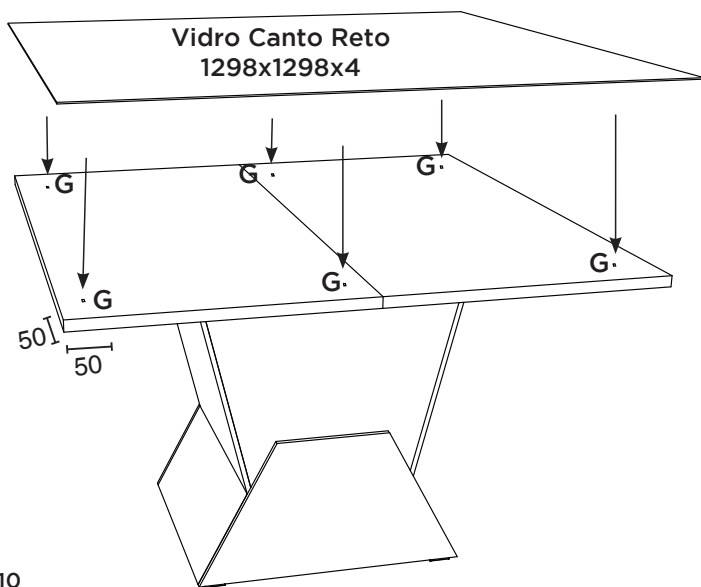

Produto Concluído (S410 + S912)
Producto Terminado (S410 + S912)
Finished Product (S410 + S912)

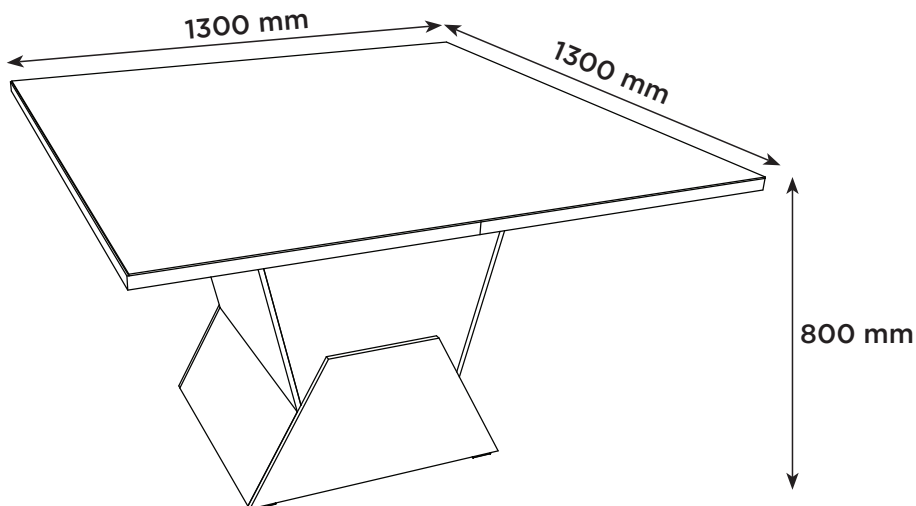

Pesos máximos recomendados com carga distribuída
Peso máximo recomendado con la carga distribuida
Recommended maximum weight with distributed load.

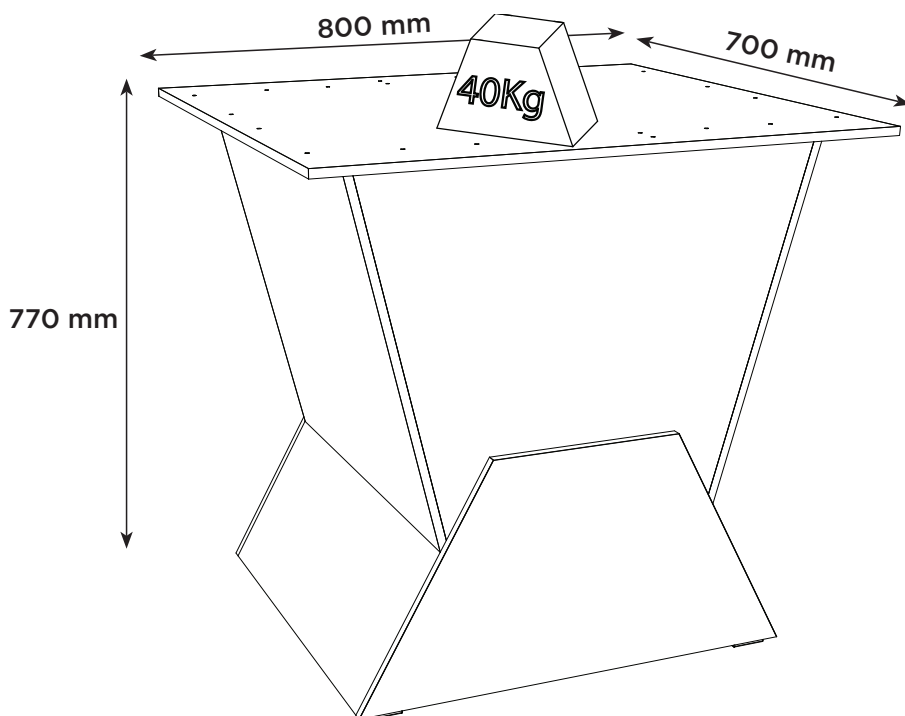

Produto Concluído
Producto terminado
Finished Product

