

Produto Concluído  
Producto terminado  
Finished Product

ITM/1123-  
Rev 000

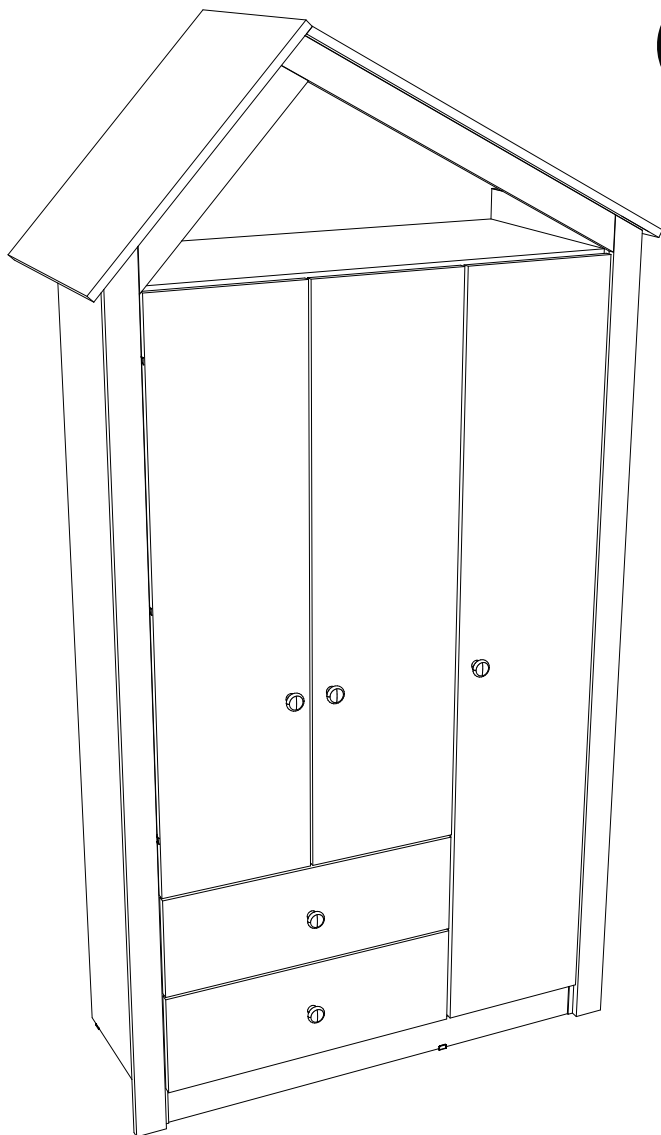

**HENN**

Ind. e Com. de Móveis Henn  
Mondaí - SC - Brasil

+55 49 3674.3500

@moveishenn  
www.henn.com.br

ITM/1123-  
**INSTRUÇÕES DE  
MONTAGEM**

INSTRUCCIONES DE MONTAJE  
ASSEMBLY INSTRUCTIONS

## Roupeiro Casinha 3 Portas 2 Gavetas

| Armario Casa 3 Puertas 2 Cajones | Wardrobe House 3 Doors 2 Drawers

1123-18 Rústico/Branco Brilho

1123-165 Rústico/Rosa Chá

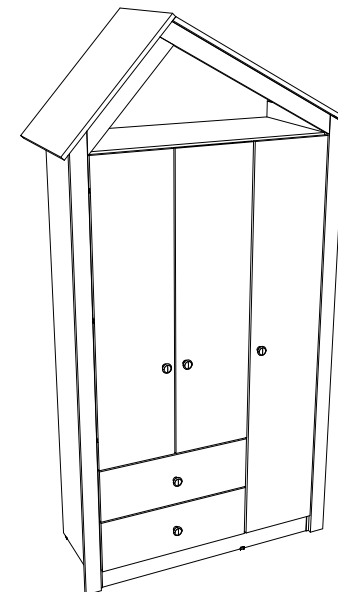

### Requisitos para montagem Requisitos para la montaje Assembly Requirements



Imagens meramente ilustrativas,  
não acompanha o produto.  
Imágenes ilustrativas, no incluidas  
con el producto.  
Illustrative images, not included  
with the product.

### AVISO

Para limpeza de seu móvel, use uma flanela seca ou umedecida, e não utilize produtos químicos que possam danificar seu produto.

### SISTEMA DE MONTAGEM

O sistema de montagem dos produtos, funciona de acordo com a ordem crescente dos números indicados no desenho. Ex: 01, 02, 03, 04... até a conclusão da montagem.

### ASSISTÊNCIA TÉCNICA

Para solicitação de Assistência Técnica você consumidor deverá entrar em contato com o Lojista o qual você realizou a compra deste produto e solicitar a assistência técnica das peças avariadas. A garantia abrange todas as peças, partes e componentes que eventualmente venham apresentar defeito de fabricação no prazo de 03 (três) meses, contando a partir da entrega do produto ao consumidor, mediante nota fiscal de compra. Se houver qualquer alteração na estrutura do produto ou ocorrer defeito por negligência do montador/consumidor em relação a instrução de montagem e manuseio, não será fornecido assistência técnica gratuita.

### ADVERTENCIA

Para limpeza de su móvil, use una flanela seca o húmeda, y no utilice productos químicos que puedan dañar su producto.

### SISTEMA DE MONTAJE

El sistema de montaje de los productos funciona de acuerdo con el orden creciente de los números indicados en el dibujo. Ej.: 01, 02, 03, 04... hasta la conclusión del montaje.

### ASISTENCIA TÉCNICA

Para solicitar Asistencia Técnica, el consumidor debe comunicarse con el Comercio que usted realizó la compra de este producto y solicita asistencia técnica para las partes dañadas. La garantía cubre todas las partes, piezas y componentes que eventualmente puedan presentar defecto de fabricación en el plazo de 03 (tres) meses, contados a partir de la entrega del producto al consumidor, mediante factura de compra. Si se produce algún cambio en la estructura del producto o se produce un defecto por negligencia del montador/consumidor en relación con las instrucciones de montaje y manipulación, no se prestará asistencia técnica gratuita.

### NOTICE

To clean your furniture, use a dry or wet cloth, and do not use chemicals that may damage your product.

### ASSEMBLY SYSTEM

The products' assembly system works according to the increasing order of the indicated numbers. For example: 01, 02, 03, 04 ... to the end of the assembly.

### TECHNICAL ASSISTANCE

To request Technical Assistance, the consumer must contact the retailer from whom you purchased this product and request technical assistance for the damaged parts. The warranty covers all parts, parts and components that may eventually present a manufacturing defect within a period of 03 (three) months, counting from the delivery of the product to the consumer, by means of a purchase invoice. If there is any change in the structure of the product or defect occurs due to negligence of the assembler/consumer in relation to the assembly and handling instruction, free technical assistance will not be provided.

## ACESSÓRIOS | ACCESORIOS | ACCESSORIES

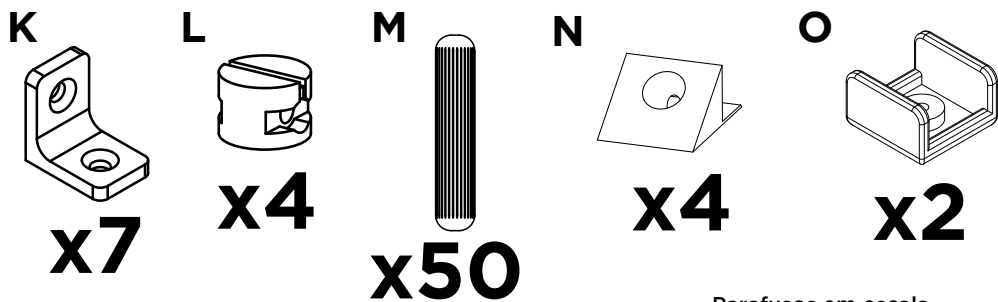
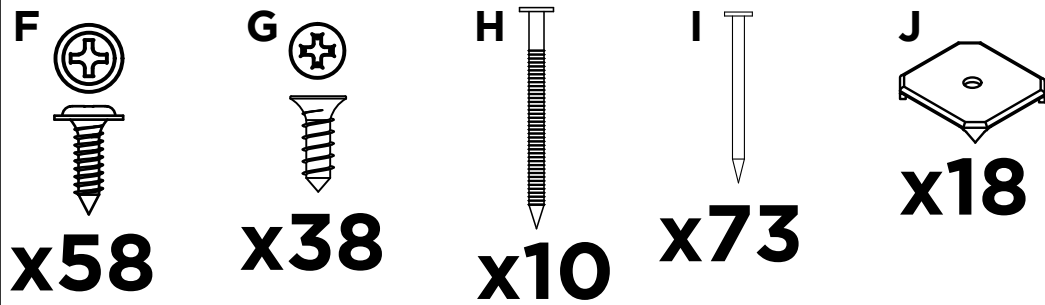
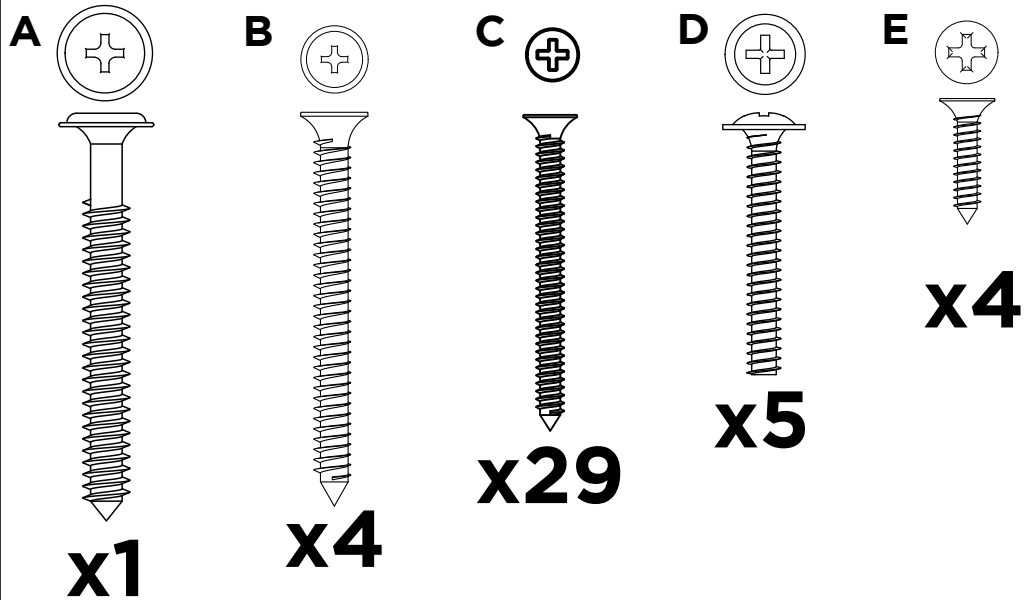

Parafusos em escala  
Tornillos escalados  
Scaled screws **1:1**

## PASSO 16

ACESSÓRIOS REQUERIDOS

AD		30
----	---	----

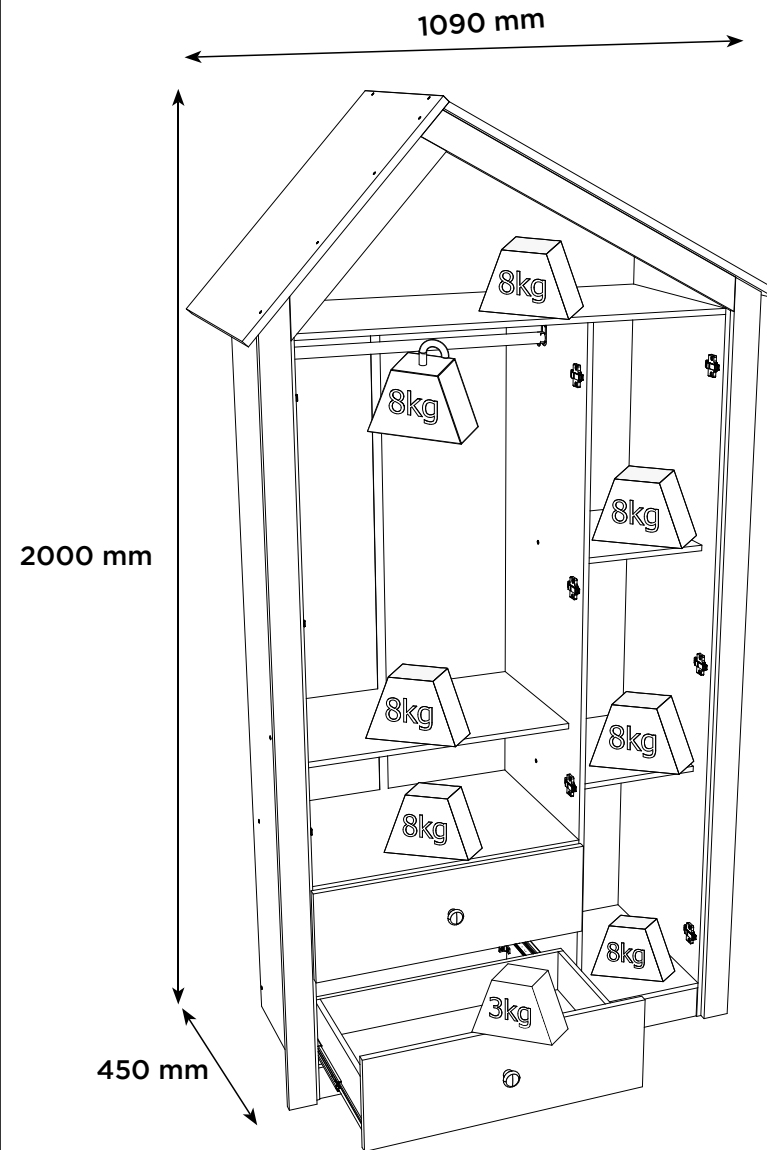

Pesos máximos recomendados com carga distribuída  
Peso máximo recomendado con la carga distribuida  
Recommended maximum weight with distributed load.

ACESSÓRIOS REQUERIDOS

E		04
G		12
N		04
X		04

FERRAMENTAS NECESSÁRIAS

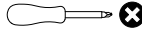

2x  
4º

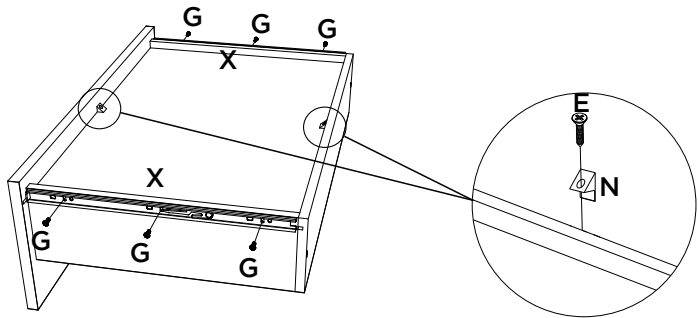

PASSO 15

ACESSÓRIOS REQUERIDOS

A		01
F		02
V		01
W		01

FERRAMENTAS NECESSÁRIAS

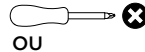

OU



Para parede: Ajustar no modo perfuração  
Para peça (10): Usar torque 5



Imprescindível a fixação do produto na parede, a não colocação destas ferragens para fixação (A, F, V e W), poderá permitir que o produto vire, causando acidente.

Es imprescindible la fijación del producto en la pared, la no colocación de estos herrajes para fijación (A, F, V y W), podrá permitir que el El producto se vuelva, causando accidente.

Indispensable to fix the product on the wall, not the placement of these attachment fittings (A, F, V and W) may allow the product to turn, causing an accident.

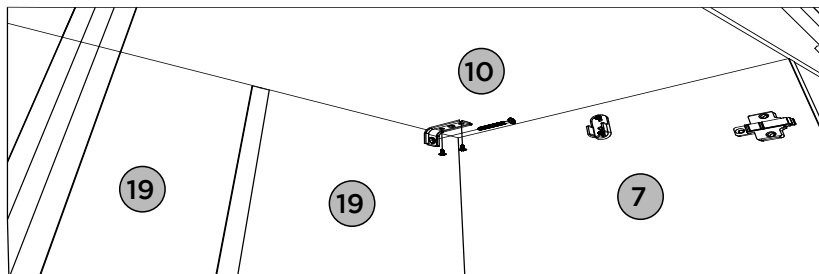
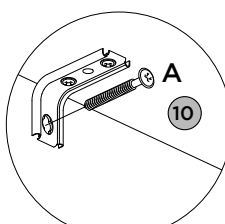
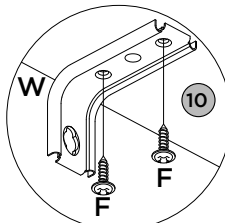

ACESSÓRIOS | ACCESORIOS | ACCESSORIES

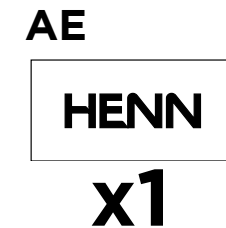
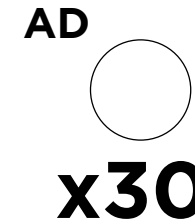
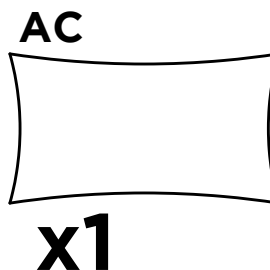
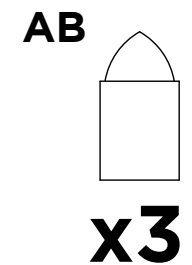
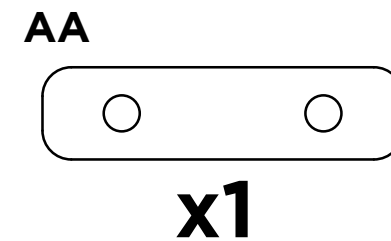
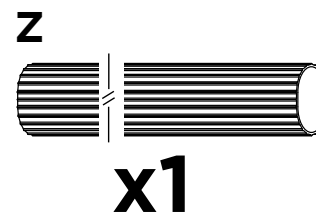
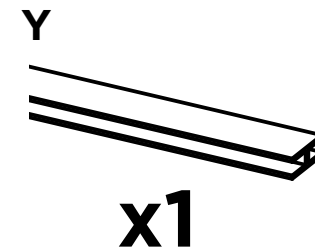
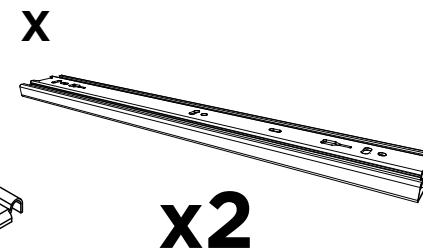
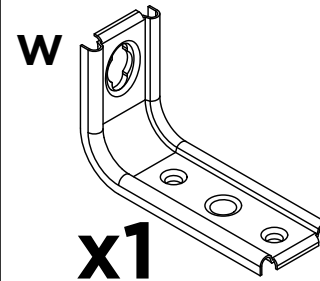
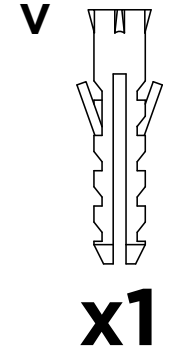
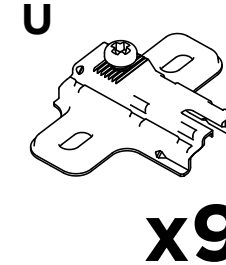
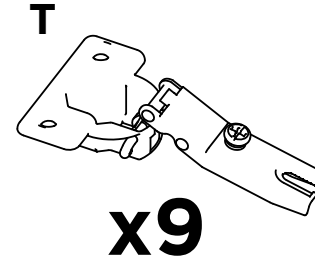
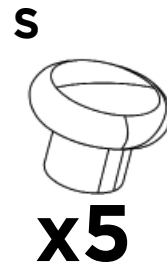
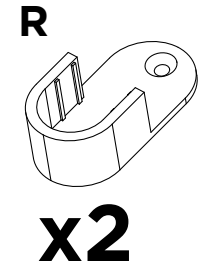
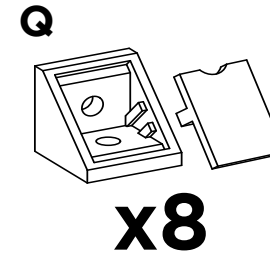
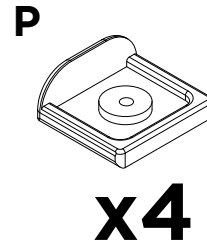

# LISTA DE PEÇAS | LISTA DE PIEZAS | LIST OF PIECES

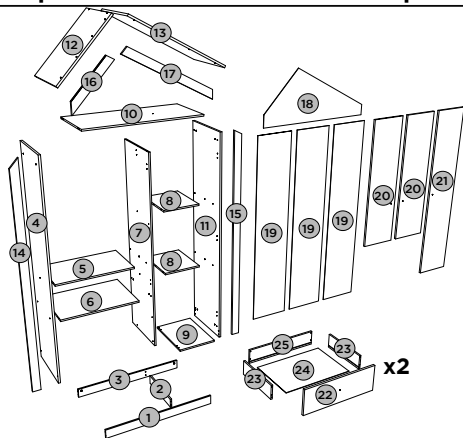

ITM/1123-

## PASSO 13

ITM/1123-

### PEÇAS REQUERIDAS

22	FRENTE DE GAVETA	x2
23	LADO DE GAVETA	x4
24	FUNDO DE GAVETA	x2
25	RIPA DE TRAS	x2

### ACESSÓRIOS REQUERIDOS

D		02
G		08
H		04
K		04
M		16
S		02
AC		

### FERRAMENTAS NECESSÁRIAS

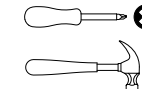

Item	Caixa Caja Box	Qty Ctd Qty	Descrição Descripción Description	Dimensões (mm)   Dimensiones (mm)   Dimensions (mm)		
				Comprimento Largo Length	Largura Ancho Width	Espessura Grosor Thickness
1	2/2	01	RODAPÉ FRONTAL   PIE DE PÁGINA FRONTAL   FRONT FOOTER	885	73	12
2	2/2	01	TRAVESSA DO RODAPÉ   BARRA TRANSVERSAL DE PIE DE PÁGINA   FOOTER CROSSBAR	380	73	12
3	2/2	01	RODAPÉ TRASEIRO   PATÍN TRASERO   BACK SKATEBOARD	885	73	12
4	1/2	01	LATERAL ESQUERDA   LADO IZQUIERDO   LEFT SIDE	1662	410	15
5	2/2	01	PRATELEIRA MAIOR   ESTANTE MÁS GRANDE   LARGER SHELF	584	350	12
6	2/2	01	TAMPO DAS GAVETAS   TAPA DE LOS CAJONES   TOP OF DRAWERS	584	410	12
7	1/2	01	DIVISÃO   DIVISIÓN   DIVISION	1493	410	12
8	2/2	02	PRATELEIRA   ESTANTE   SHELF	289	350	12
9	2/2	01	BASE   BASE   BASE	301	410	12
10	2/2	01	TAMPO   TAPA   TOP	885	410	12
11	1/2	01	LATERAL DIREITA   LADO DERECHO   RIGHT SIDE	1650	410	15
12	2/2	01	TAMPO MENOR   PEQUENA TAPA   SMALL TOP	563	445	15
13	2/2	01	TAMPO MAIOR   TOP MÁS GRANDE   TOP BIGGER	791	445	15
14	1/2	01	MOLDURA LATERAL ESQUERDA   MARCO DEL LADO IZQUIERDO   LEFT SIDE FRAME	1667	60	15
15	1/2	01	MOLDURA LATERAL DIREITA   MARCO DEL LADO DERECHO   RIGHT SIDE FRAME	1652	60	15
16	1/2	01	MOLDURA SUPERIOR MENOR   MARCO SUPERIOR PEQUEÑO   SMALL TOP FRAME	443	60	15
17	1/2	01	MOLDURA SUPERIOR MAIOR   MARCO SUPERIOR MÁS GRANDE   LARGER TOP FRAME	745	60	15
18	1/2	01	FUNDO SUPERIOR   PARTE SUPERIOR INFERIOR   UPPER BOTTOM	914	411	3
19	1/2	03	FUNDO   FONDO   BACKGROUND	1511	300	3
20	1/2	02	PORTA MENOR   PUERTA MÁS PEQUEÑA   SMALLER DOOR	1097	295	15
21	1/2	01	PORTA   PUERTA   DOOR	1505	295	15
22	2/2	02	FRENTE DE GAVETA   FRENTE DEL CAJÓN   DRAWER FRONT	592	200	15
23	2/2	04	LADO DE GAVETA   LATERAL DEL CAJÓN   DRAWER SIDE	350	110	12
24	2/2	02	FUNDO DE GAVETA   FONDO DEL CAJÓN   DRAWER BOTTOM	551	361	3
25	2/2	02	RIPA DE TRÁS   TRAVESAÑO TRASERO   REAR CLAPBOARD	564	110	12

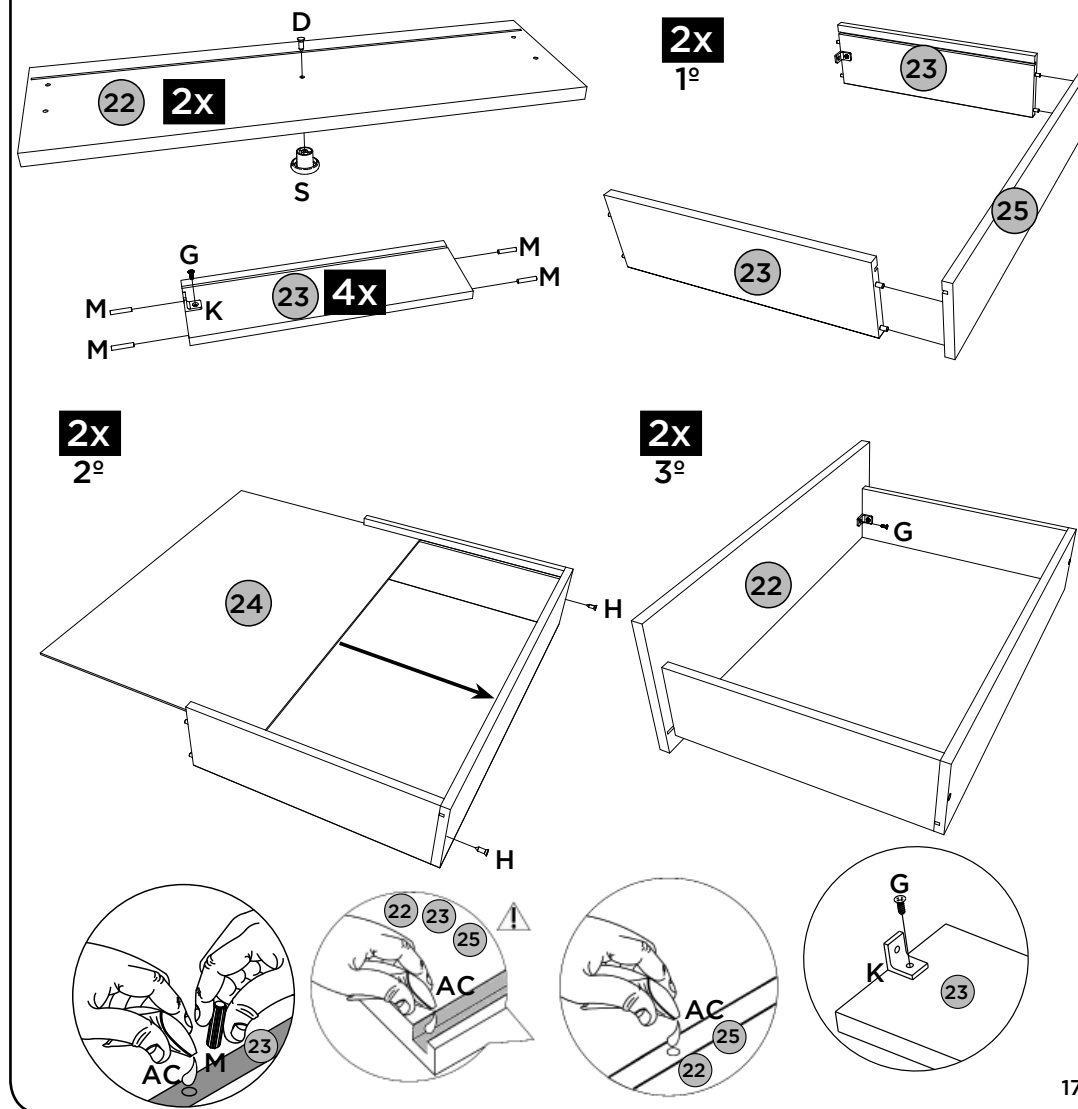

# PASSO 12

ITM/I123-

## PEÇAS REQUERIDAS

20	PORTA MEMOR	x2
21	PORTA	x1

## ACESSÓRIOS REQUERIDOS

D		03
F		18
S		03
T		09

## FERRAMENTAS NECESSÁRIAS

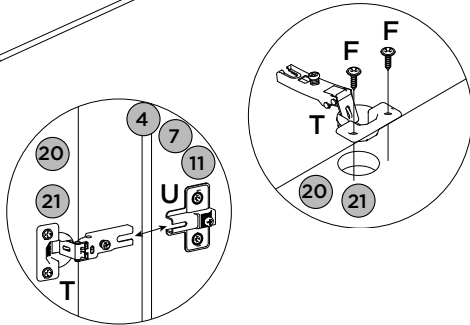
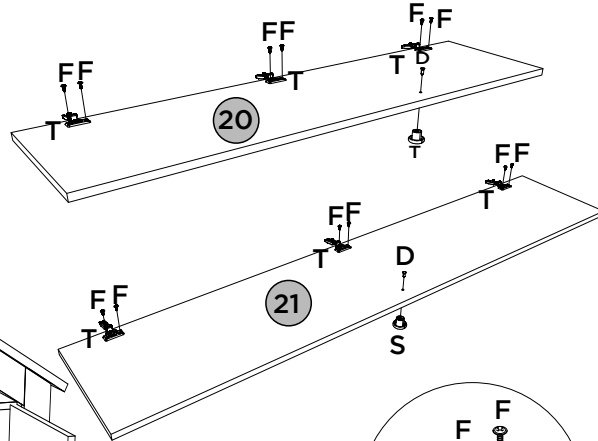

Vídeo: Instalar e regular Dobradiças

Video: Instale y ajuste las bisagras

Video: Install and adjust hinges

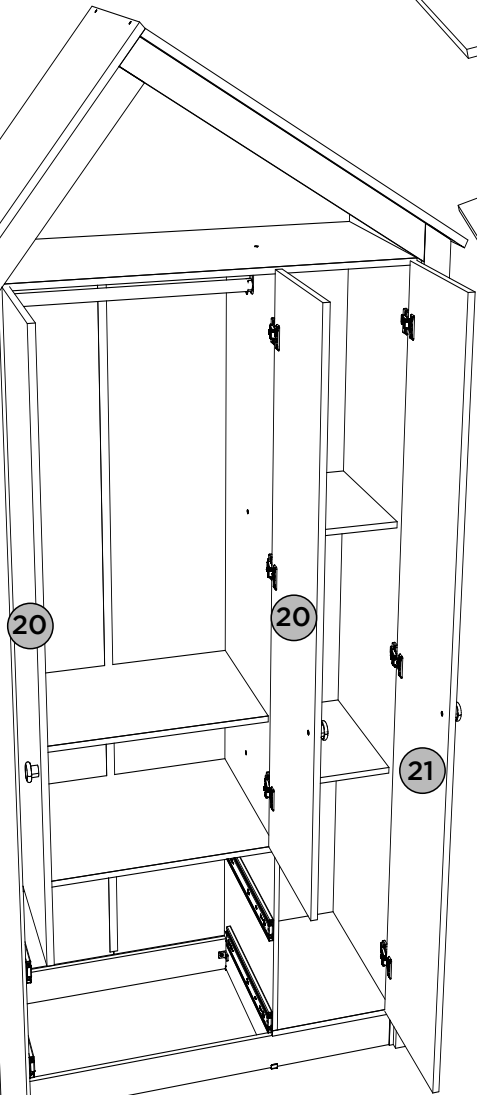

# PASSO 1

ITM/I123-

## PEÇAS REQUERIDAS

1	RODAPÉ FRONTAL	x1
2	TRAVESSA DO RODAPÉ	x1
3	RODAPÉ TRASEIRO	x1

## ACESSÓRIOS REQUERIDOS

F		02
H		02
K		02
L		04
M		08
O		02

## FERRAMENTAS NECESSÁRIAS

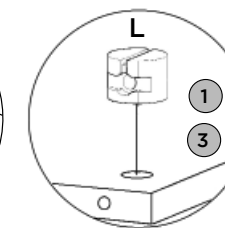
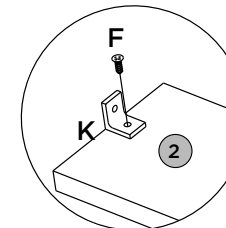
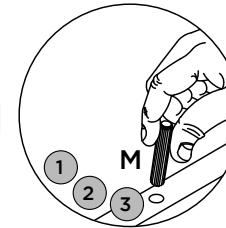
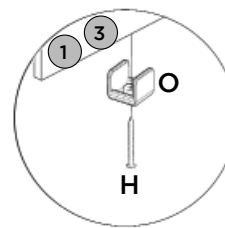
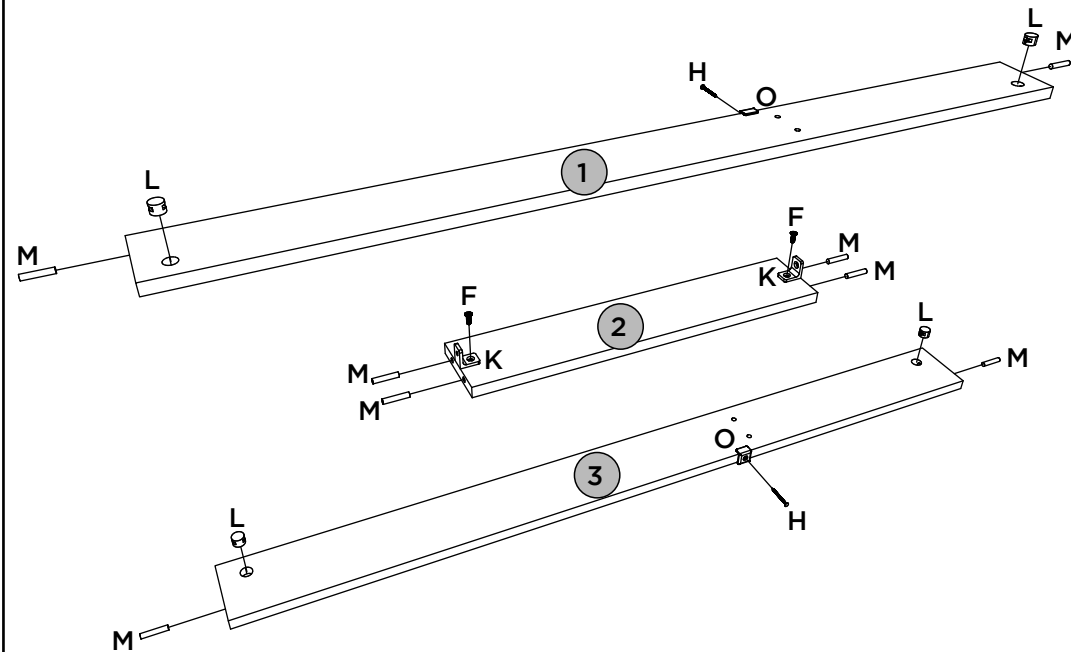
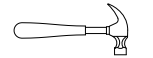
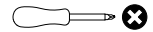

## PASSO 2

ITM/I123-

### PEÇAS REQUERIDAS

4	LATERAL ESQUERDA	x1
5	PRATELEIRA MAIOR	x1
6	TAMPO DAS GAVETAS	x1

### ACESSÓRIOS REQUERIDOS

F		06
G		08
H		02
M		08
P		02
R		01
U		03
X		02

### FERRAMENTAS NECESSÁRIAS

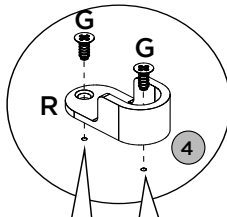
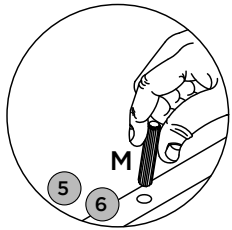
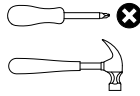

Observe:  
Furos  
pré-marcados

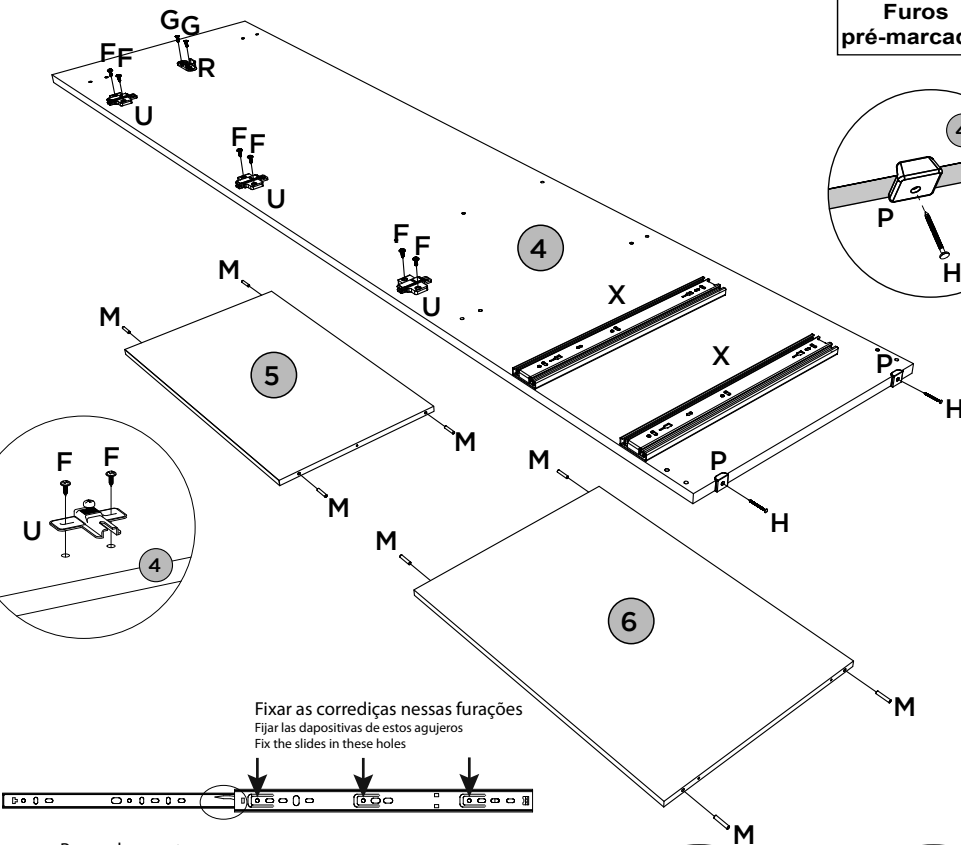
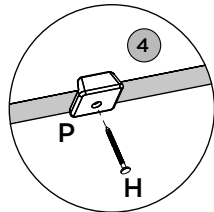

Fixar as corredeiras nessas furações  
Fijar las dispositivos de estos agujeros  
Fix the slides in these holes

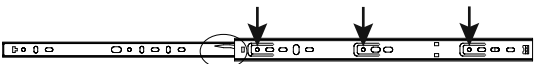

Para a desmontagem  
da corredeira, siga a  
instrução ao lado

Para el desmontaje  
de la diapositiva, siga las  
instrucción en el lado

For disassembly  
of the slide, follow the  
instruction on the side

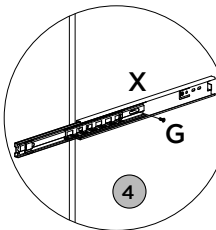
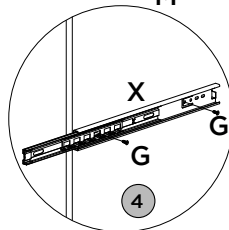
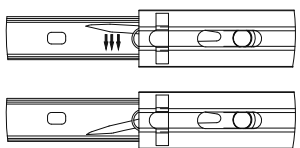

## PASSO 11

ITM/I123-

### PEÇAS REQUERIDAS

18	FUNDO SUPERIOR	x1
----	----------------	----

### ACESSÓRIOS REQUERIDOS

I		16
J		06

### FERRAMENTAS NECESSÁRIAS

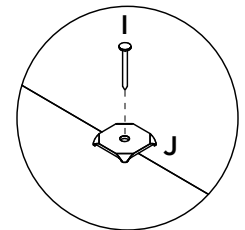
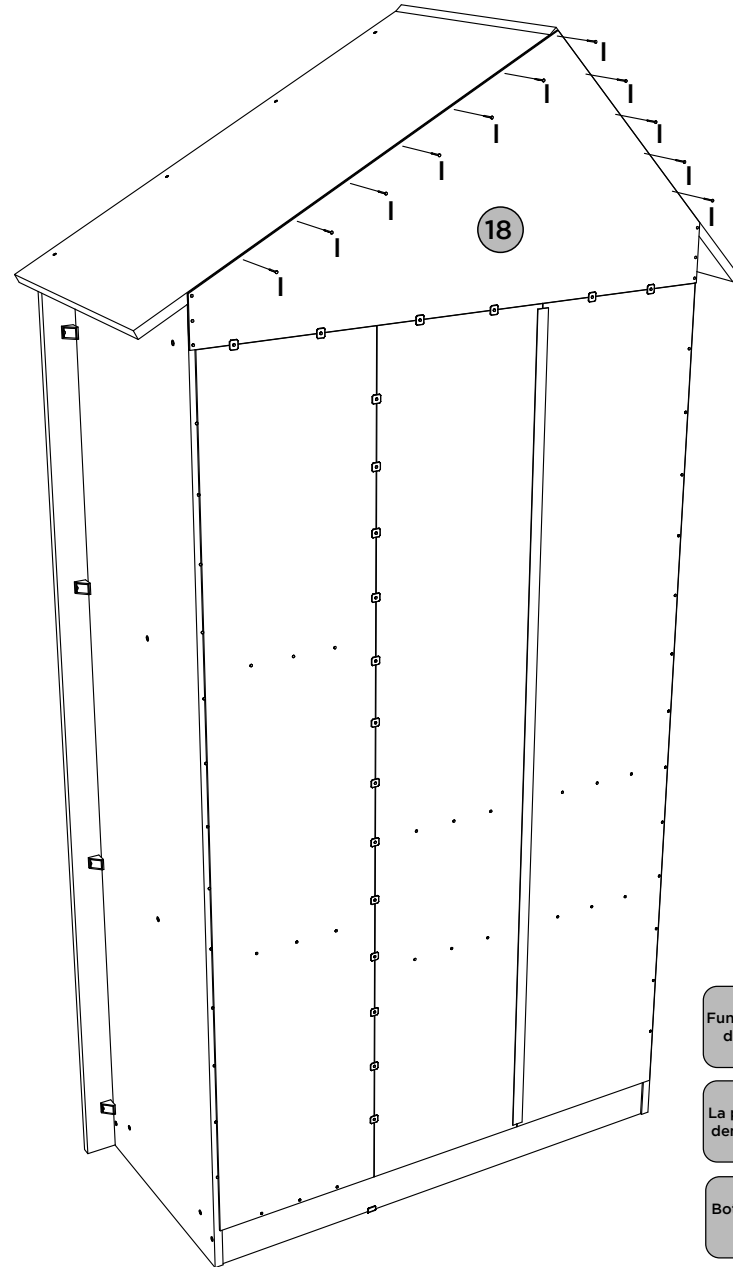
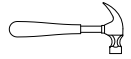

Fundo (18) deverá ser colocado 3mm para  
dentro das bordas do tampo (12 e 13).

La parte inferior (18) debe colocarse 3mm  
dentro de los bordes superiores (12 y 13).

Bottom (18) should be placed 3mm inside  
the top edges (12 and 13).

# PASSO 10

ITM/I123-

## PEÇAS REQUERIDAS

14	MOLDURA LATERAL ESQUERDA	x1
15	MOLDURA LATERAL DIREITA	x1

## ACESSÓRIOS REQUERIDOS

C		02
F		16
Q		08

## FERRAMENTAS NECESSÁRIAS

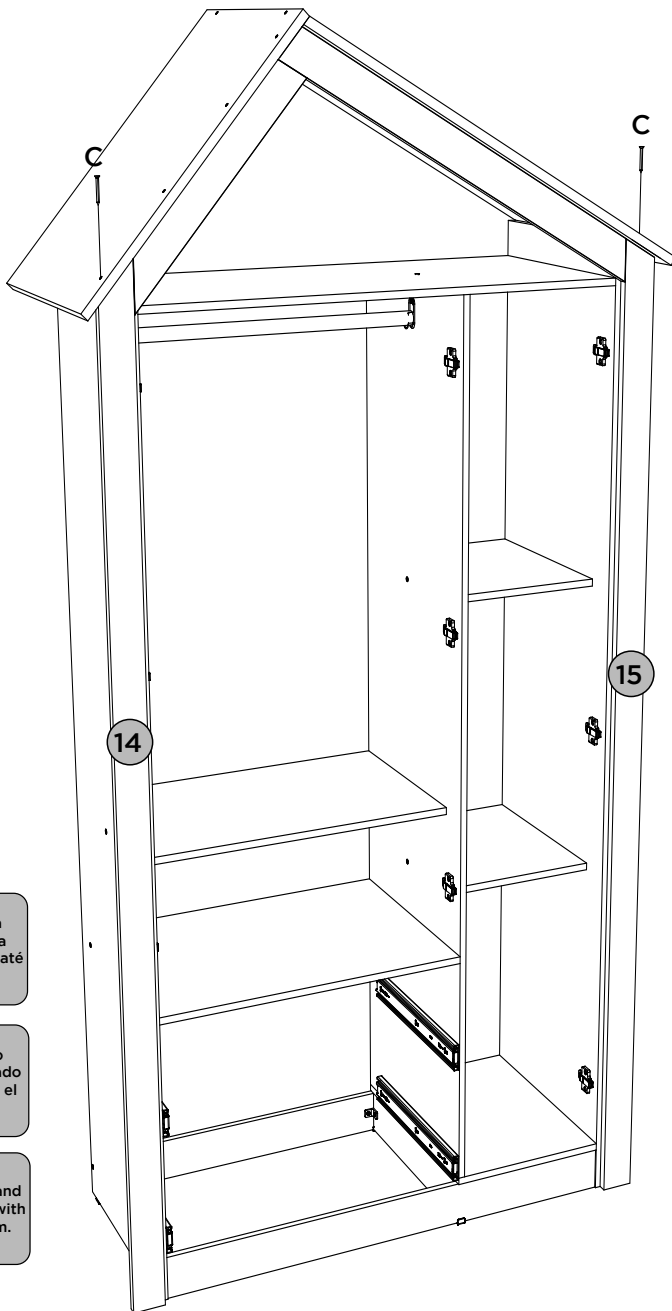
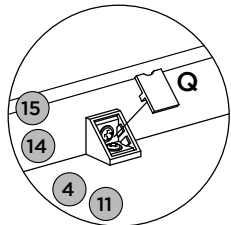
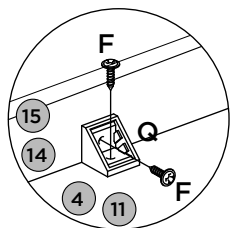

Após colocação do telhado parafusar moldura lateral (14 e 15) 2mm sobre a borda da frente da lateral alinhada com a mesma. Medida da borda até a moldura deverá ser de 58mm.

Después de colocar el techo, atornille el marco lateral (14 y 15) 2mm sobre el borde frontal del lado alineado con él. La medida desde el borde hasta el marco debe ser de 58 mm.

After placing the roof, screw the side frame (14 and 15) 2mm over the front edge of the side aligned with it. Measure from edge to frame should be 58mm.

# PASSO 3

ITM/I123-

## PEÇAS REQUERIDAS

7	DIVISÃO	x1
8	PRATELEIRA	x2
9	BASE	x1

## ACESSÓRIOS REQUERIDOS

F		06
G		08
M		14
R		01
U		03
X		02

## FERRAMENTAS NECESSÁRIAS

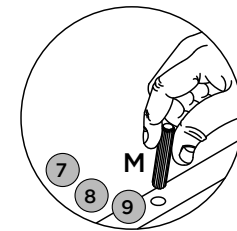
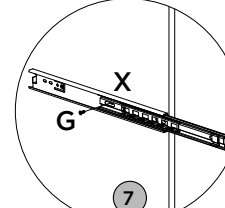
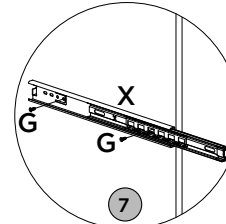
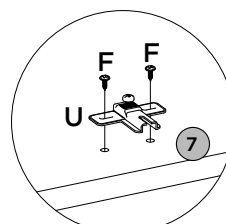
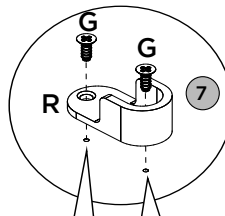
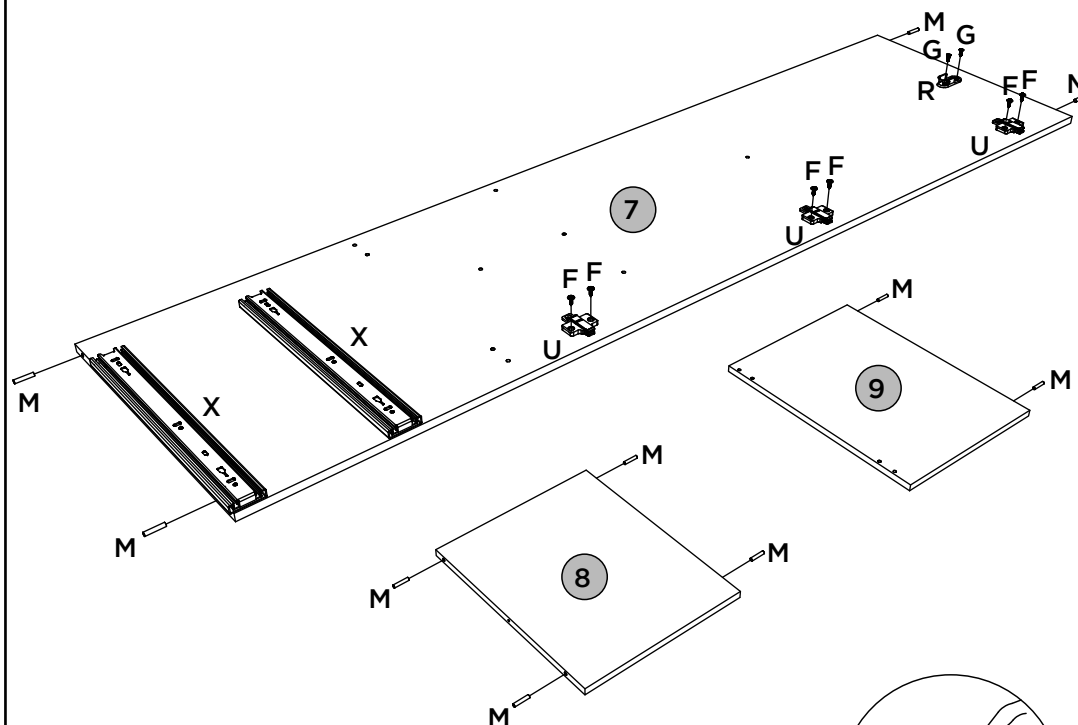
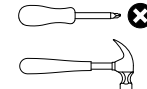

Observe:  
Furos pré-marcados

# PASSO 4

ITM/I123-

## PEÇAS REQUERIDAS

## ACESSÓRIOS REQUERIDOS

## FERRAMENTAS NECESSÁRIAS

10	TAMPO	x1
11	LATERAL DIREITA	x1

F		06
H		02
M		04
P		02
U		03

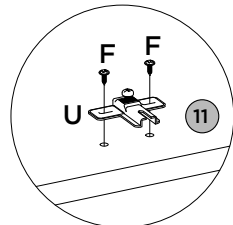
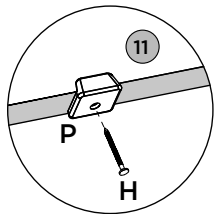
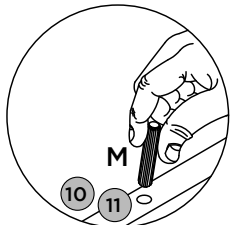
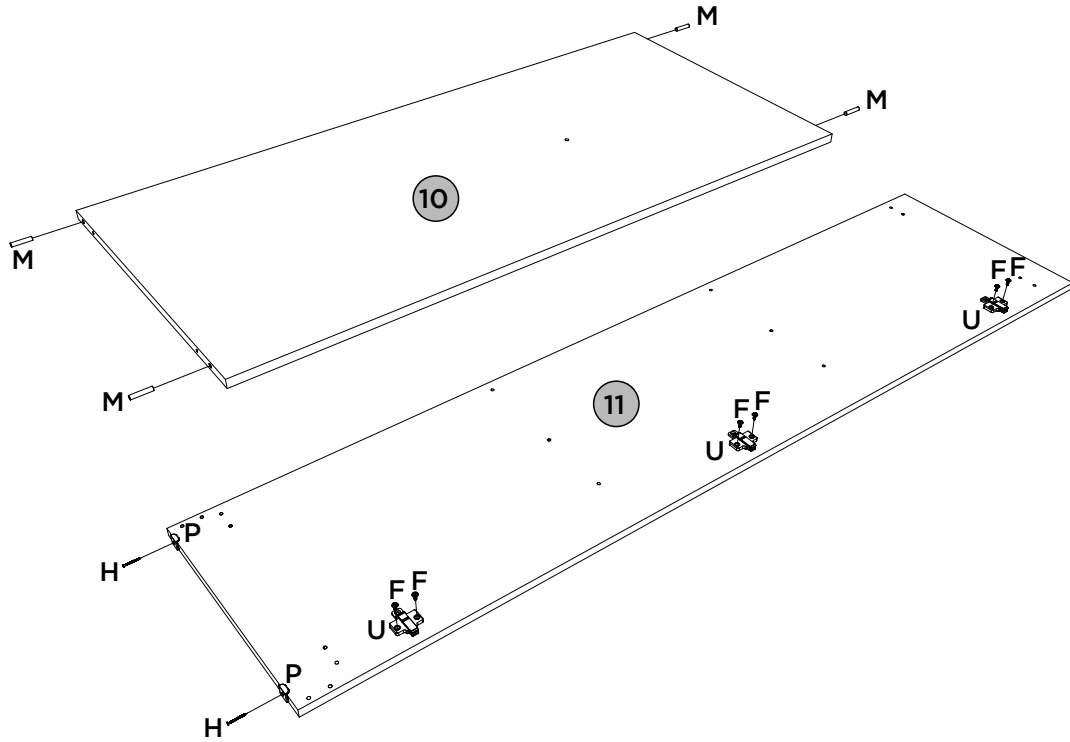
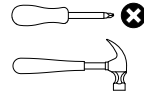

# PASSO 9

ITM/I123-

## PEÇAS REQUERIDAS

## ACESSÓRIOS REQUERIDOS

## FERRAMENTAS NECESSÁRIAS

12	TAMPO MENOR	x1
13	TAMPO MAIOR	x1
16	MOLDURA SUPERIOR MENOR	x1
17	MOLDURA SUPERIOR MAIOR	x1

C		08
G		02
AA		01

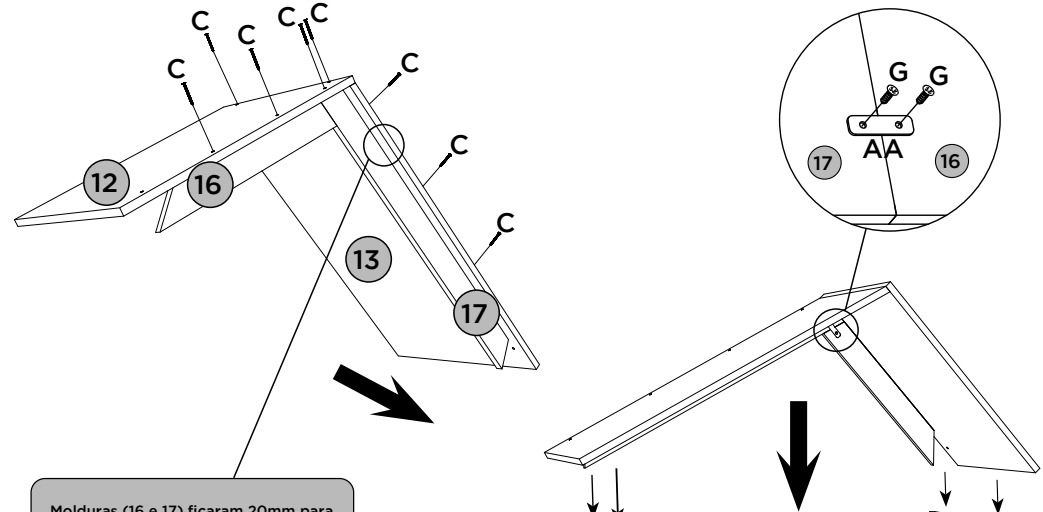
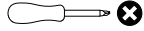

Molduras (16 e 17) ficam 20mm para dentro das bordas dos tampos (12 e 13)

Los marcos (16 y 17) estaban a 20 mm dentro de los bordes de las tapas (12 y 13)

Frames (16 and 17) were 20mm inside the edges of the tops (12 and 13)

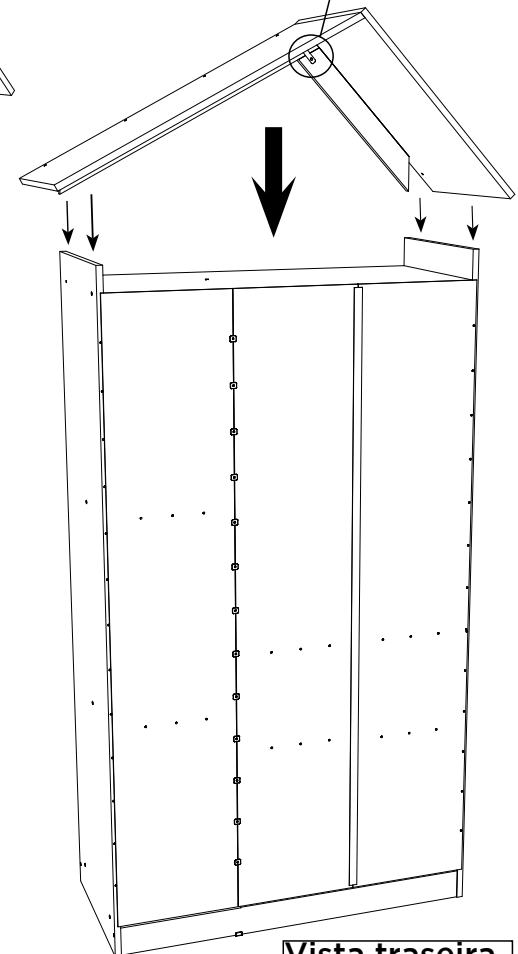

Vista traseira 13

# PASSO 8

ITM/I123-

## PEÇAS REQUERIDAS

11	LATERAL DIREITA	x1
19	FUNDO	x3

## ACESSÓRIOS REQUERIDOS

B		02
C		06
F		02
I		57
J		12
K		01
Y		01
Z		01

## FERRAMENTAS NECESSÁRIAS

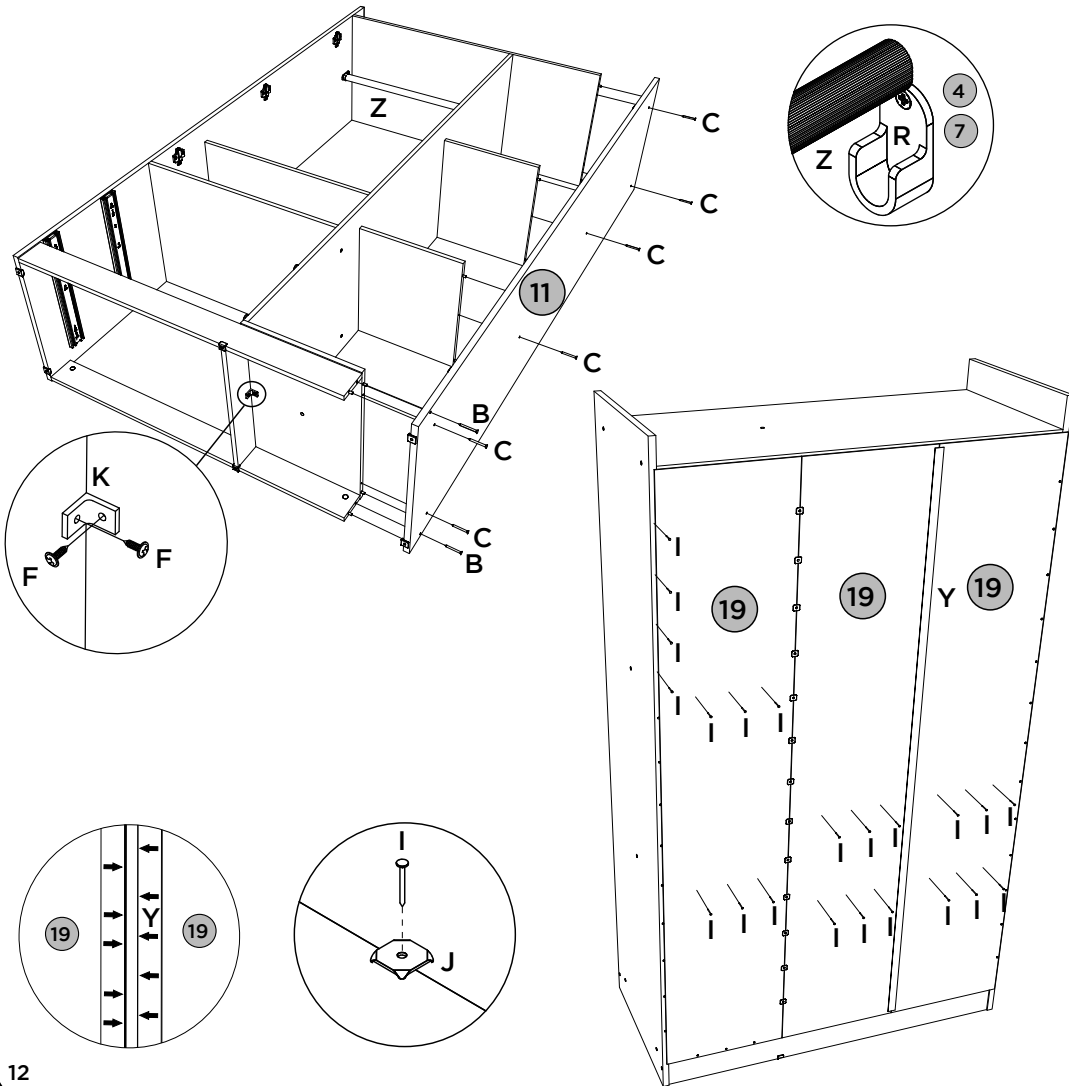
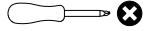

# PASSO 5

ITM/I123-

## PEÇAS REQUERIDAS

1	RODAPÉ FRONTAL	x1
2	TRAVESSA DO RODAPÉ	x1
3	RODAPÉ TRASEIRO	x1

## ACESSÓRIOS REQUERIDOS

F		02
---	--	----

## FERRAMENTAS NECESSÁRIAS

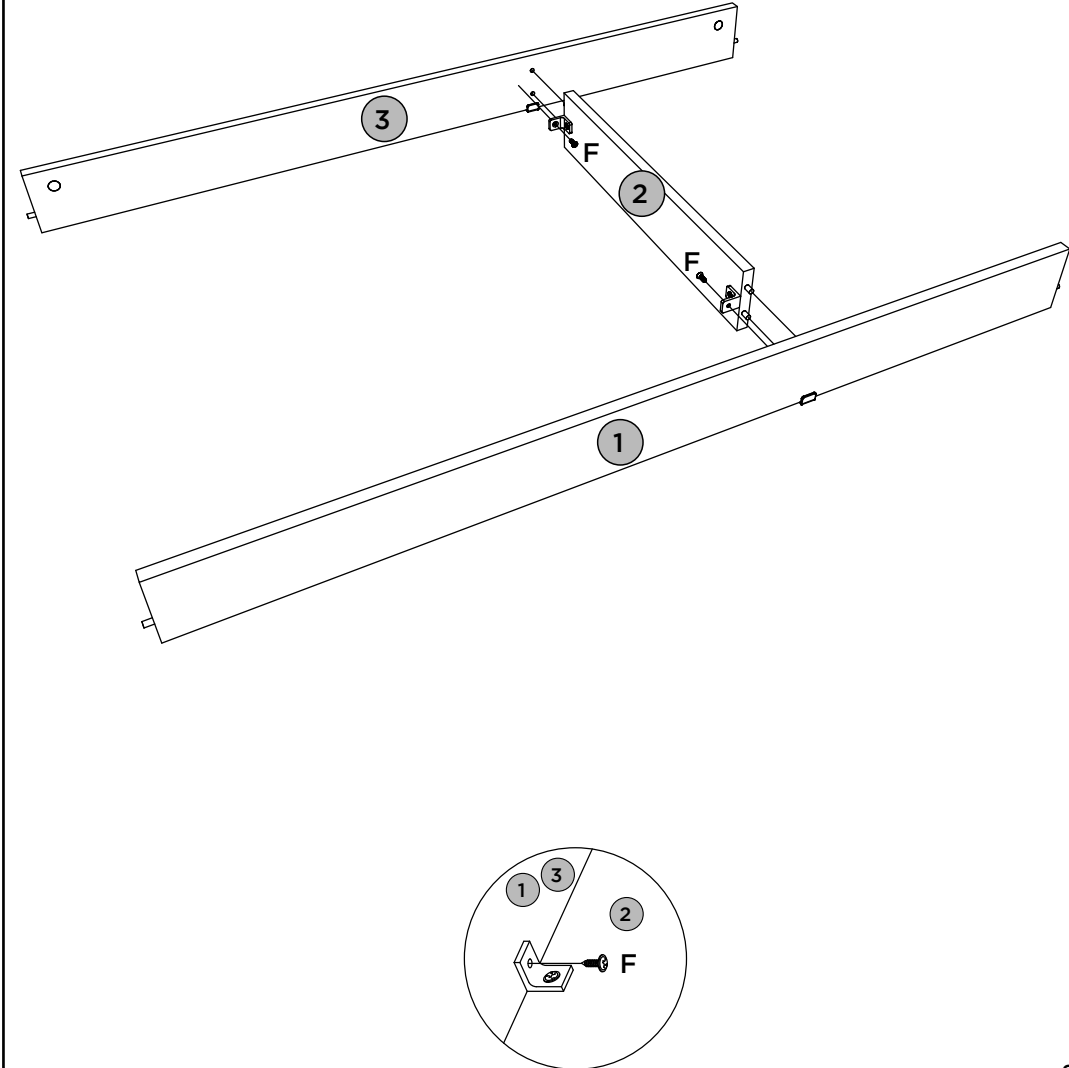
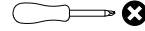

# PASSO 6

ITM/I123-

## PEÇAS REQUERIDAS

4	LATERAL ESQUERDA	x1
5	PRATELEIRA MAIOR	x1
6	TAMPO DAS GAVETAS	x1

## ACESSÓRIOS REQUERIDOS

B		02
C		03

## FERRAMENTAS NECESSÁRIAS

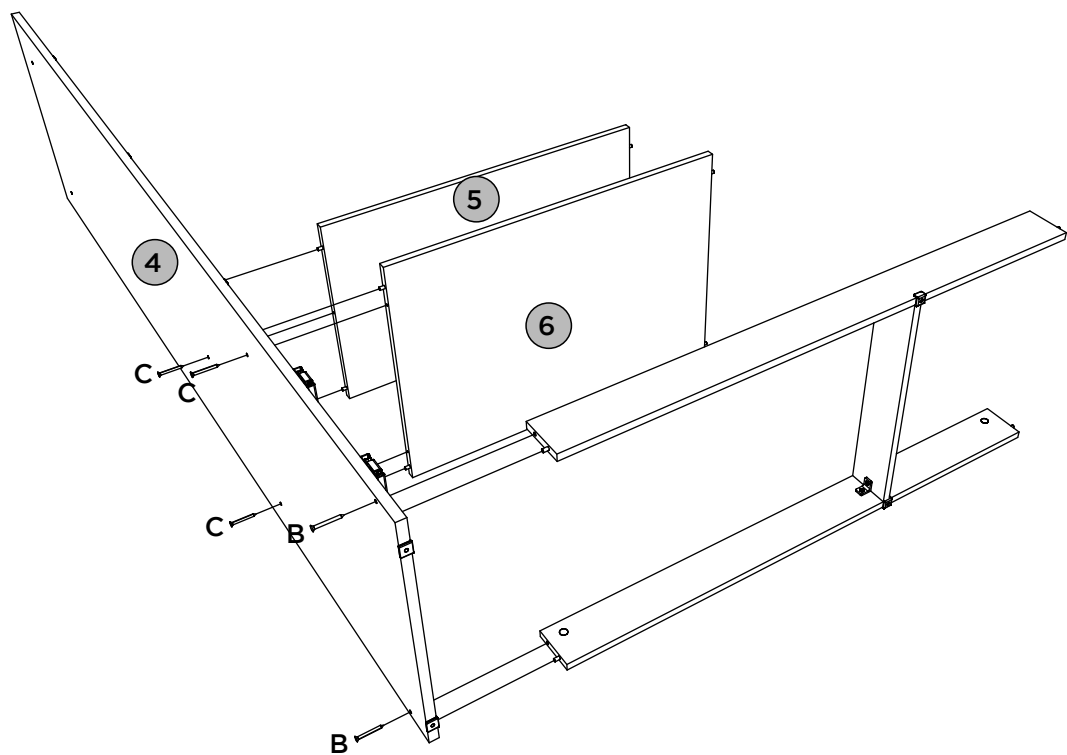
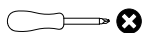

# PASSO 7

ITM/I123-

## PEÇAS REQUERIDAS

7	DIVISÃO	x1
8	PRATELEIRA	x2
9	BASE	x1
10	TAMPO	x1

## ACESSÓRIOS REQUERIDOS

C		10
---	--	----

## FERRAMENTAS NECESSÁRIAS

