

# MANUAL DE MONTAGEM / ASSEMBLY INSTRUCTIONS / PLANO DE ARMADO

**Antes de montar o móvel, leia com atenção o manual de montagem!**  
**Before assembling the furniture, carefully read the assembly instructions!**  
**Antes de armar el mueble, lea con atención el manual de ensamble!**

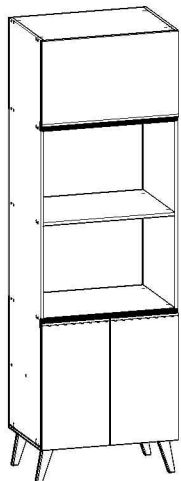

**Ref.: 1251**

**genialflex**  
ambientes incríveis para todos

Parabéns! Você comprou um produto de excelente qualidade, fabricado com chapa de madeira de MDP ou MDF, extraída de florestas renováveis. Possui alta resistência e design atual.

Congratulations! You have purchased a product of excellent quality, made from MDP or MDF wood veneer, extracted from renewable forests. It has high strength and current design.

Felicitaciones! Usted compró a un producto de excelente calidad, fabricado con placa de madera de MDP o MDF, proveniente de florestas renovables. Tiene alta resistencia y diseño actual.



**ATENÇÃO  
ATTENTION  
ATENCIÓN**

- 1)** Verifique todas as peças antes de começar a montagem.  
Check all parts before starting assembly.  
Verifique todas las partes antes de empezar el armado.
- 2)** Ao começar a montagem, não apoie as peças na parede.  
When starting the assembly, do not support the parts on the wall.  
Al empezar el armado, no apoyes las partes en la pared.
- 3)** Ao colocar as peças e ferragens de lado, cuidado para não perde-las.  
When placing parts and hardware aside, be careful not to lose them.  
Al poner las piezas y herrages a parte, cuidado para no dañarlas.
- 4)** O móvel deve ser montado no chão, para isso, use a própria caixa para proteger e não danificar o piso.  
The furniture must be mounted on the floor, to do this, use the box itself to protect and not damage the floor.  
El mueble suele ser armado al piso, para eso, use la propia caja para protegerlo y no dañar al piso.

- 5)** Comece a montagem seguindo as instruções passo a passo.  
Begin assembly by following the step-by-step instructions.  
Comience el armado siguiendo la instrucciones paso a paso.

- 6)** É de responsabilidade do montador seguir as intruções desse manual, que são fundamentais para a estrutura do móvel.  
It's the assembler's responsibility to follow the instructions in this manual, which are fundamental to the structure of the furniture.  
Es de responsabilidad del armador seguir las instrucciones de este manual, que son fundamentales para la estructura del mueble.

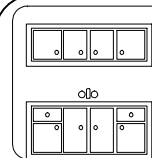

**CUIDADOS  
CARE  
CUIDADO**

- 1)** A conservação e limpeza deve ser feita com um pano levemente umedecido com água.  
Care and cleaning should be done with a cloth slightly moistened with water.  
La conservación y limpieza debe ser hecha con un trapo levemente humedecido en agua.
- 2)** Não use produtos abrasivos, como saponáceo, detergentes e esponja de aço.  
Do not use abrasive products, such as soap, detergents and steel sponge.  
No use productos abrasivos, como saponáceo, detergentes y esponja de acero.
- 3)** Não use cera ou óleo para dar brilho ao móvel.  
Do not use wax or oil to shine the furniture.  
No use cera o aceites para darle brillo al mueble.
- 4)** Não expor o móvel a interpéries e nem ao calor excessivo.  
Do not expose the furniture to weather or excessive heat.  
No exponer el mueble a interperies ni al calor excesivo.
- 5)** Ao terminar a montagem, limpe o ambiente e o móvel.  
When the assembly is finished, clean the room and the furniture.  
Al terminar el armado, limpie al ambiente y al mueble.

## FERRAMENTAS / TOOLS / HERRAMIENTAS



MARTELO  
HAMMER  
MARTILLO



MARTELO DE BORRACHA  
RUBBER HAMMER  
MARTILLO GOMA

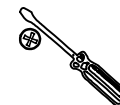

CHAVE PHILLIPS  
PHILLIPS SCREWDRIVER  
LLAVE PHILLIPS









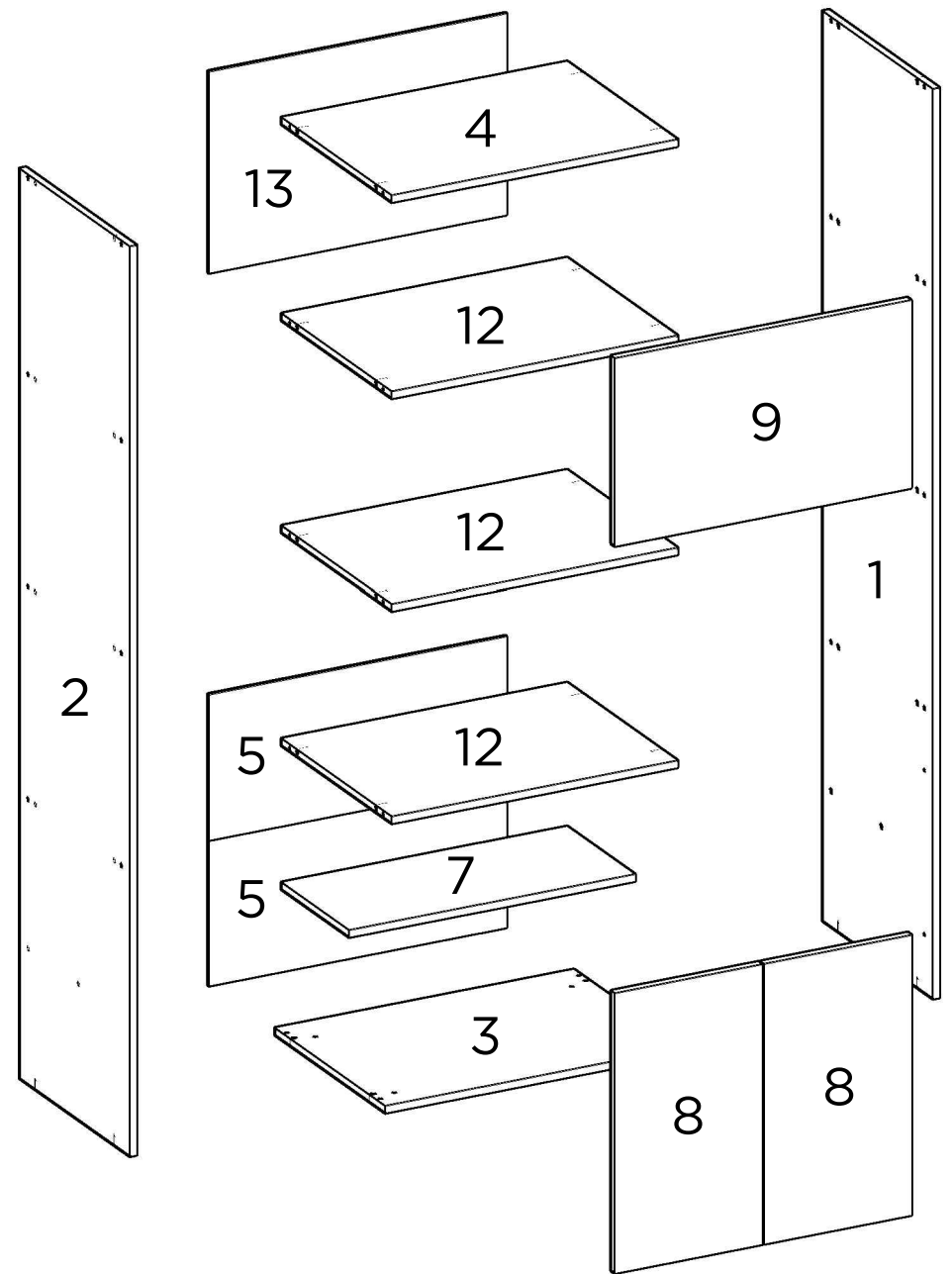



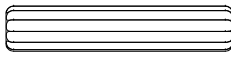

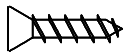
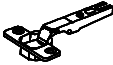

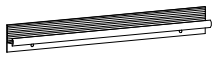
TRENA  
MEASURING TAPE  
CINTA MÉTRICA

**PEÇAS / PARTS / PIEZAS**

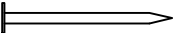
Nº No Num	DESCRIÇÃO DESCRIPTION DESCRIPCIÓN	QTD QTY CANT
1	LATERAL DIREITA RIGHT SIDE PANEL LATERAL DERECHA	1
2	LATERAL ESQUERDA LEFT SIDE PANEL LATERAL IZQUIERDA	1
3	BASE BOTTOM BASE	1
4	TAMPO TOP TABLERO	1
5	COSTA INFERIOR LOWER BACK PANEL TRASERO INFERIOR	2
7	PRATELEIRA PLATE PANEL REPISA	1
8	PORTA DOOR PUERTA	2
9	PORTA BASCULANTE TILTING DOOR PUERTA BASCULANTE	1
12	BASE / PRATELEIRA BOTTOM PANEL / PLATE PANEL BASE / REPISA	3
13	COSTA SUPERIOR UPPER BACK PANEL TRASERO SUPERIOR	1

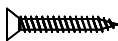
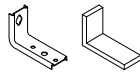

## FERRAGENS / HARDWARE / HERRAJES

CÓD CODE COD	DESCRIÇÃO DESCRIPTION DESCRIPCIÓN	QTD QTY CANT
A	 CAVILHA WOODEN DOWEL TARUGO	20
B	 SUPORTE DE PRATELEIRA SHELF SUPPORT SOPORTE DE ESTANTES	4
C	 PARAFUSO 4X14mm SCREW 4X14mm TORNILLO 4X14mm	33
D	 DOBRADIÇA HINGE BIZAGRA	6
E	 CALÇO PARA DOBRADIÇA HINGE SHED CALZO DE BISAGRA	6
F	 PUXADOR PULLER TIRADOR	3
G	 PÉ LEG PATA	4
H	 PARAFUSO 5X50mm SCREW 5X50mm TORNILLO 5X50mm	1
I	 PARAFUSO 3,5X40mm SCREW 3,5X40mm TORNILLO 3,5X40mm	20
J	 PREGO NAIL CLAVO	56
K	 PERFIL I PROFILE I PERFIL I	1
L	 PARAFUSO 3,5X25mm SCREW 3,5X25mm TORNILLO 3,5X25mm	1
M	 SUPORTE DE FIXAÇÃO MOUNTING SUPPORT SOPORTE DE MONTAJE	1
N	 BUCHA PLÁSTICA PLASTIC BUSHING CASQUILLO PLÁSTICO	1
O	 PARAFUSO 4X16mm SCREW 4X16mm TORNILLO 4X16mm	16
P	 TAPA-FURO HOLE COVER TAPA AGUJERO	4
Q	 PISTÃO PISTON PISTÓN	1

UTILIZE A RÉGUA PARA IDENTIFICAR OS PARAFUSOS  
USE THE RULER TO IDENTIFY THE SCREWS  
UTILICE LA REGLA PARA IDENTIFICAR LOS TORNILLOS

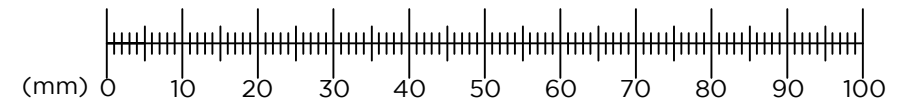

**PESO SUPORTADO / WEIGHT SUPPORTED / PESO SOPORTADO**

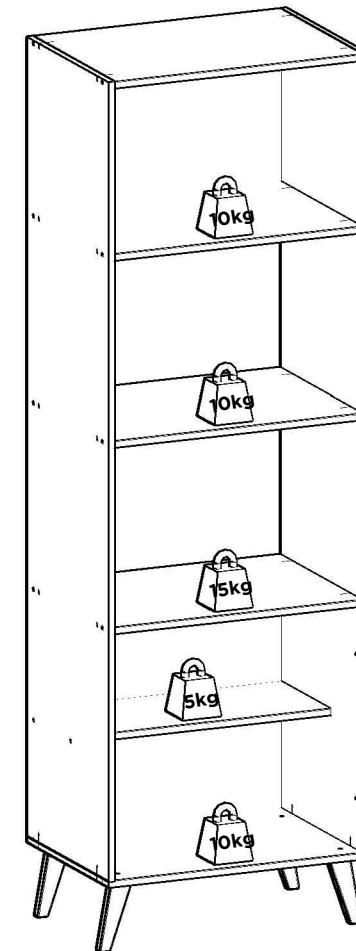

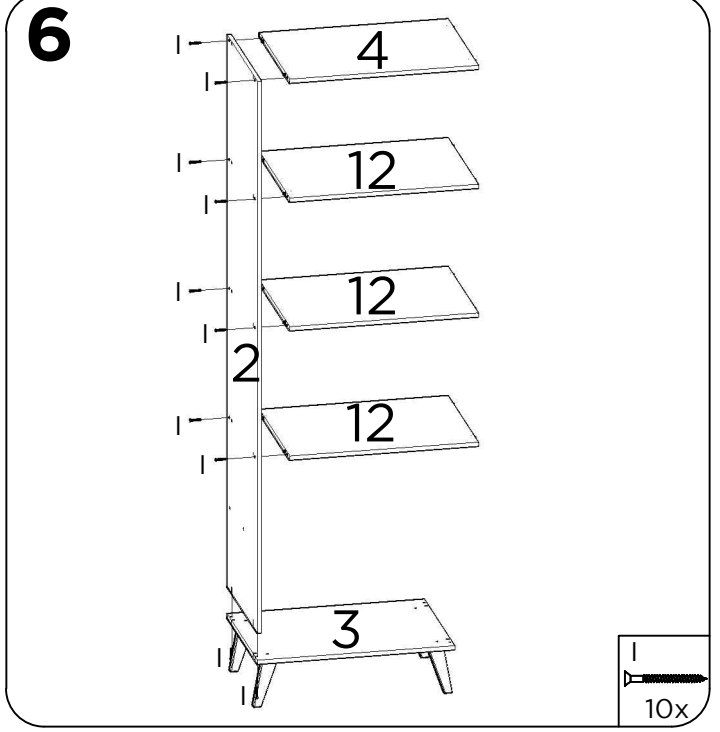
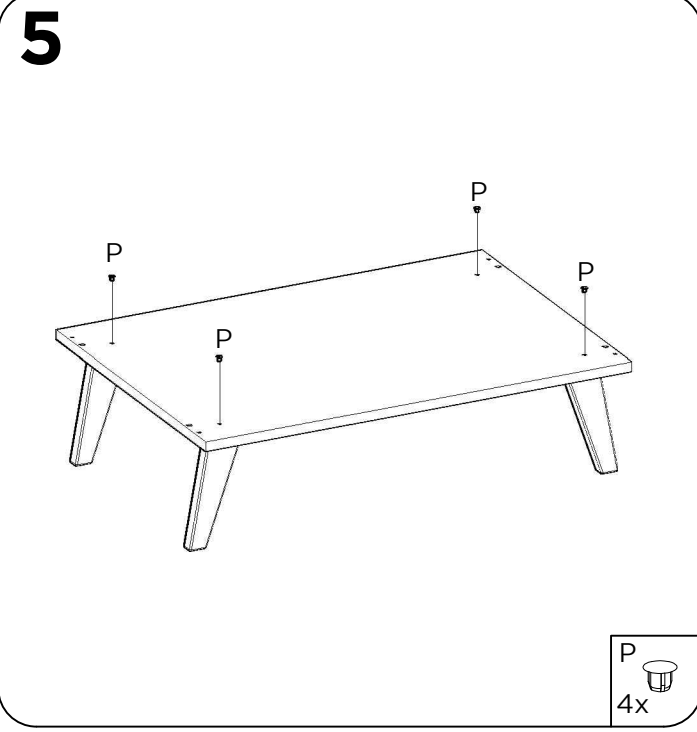
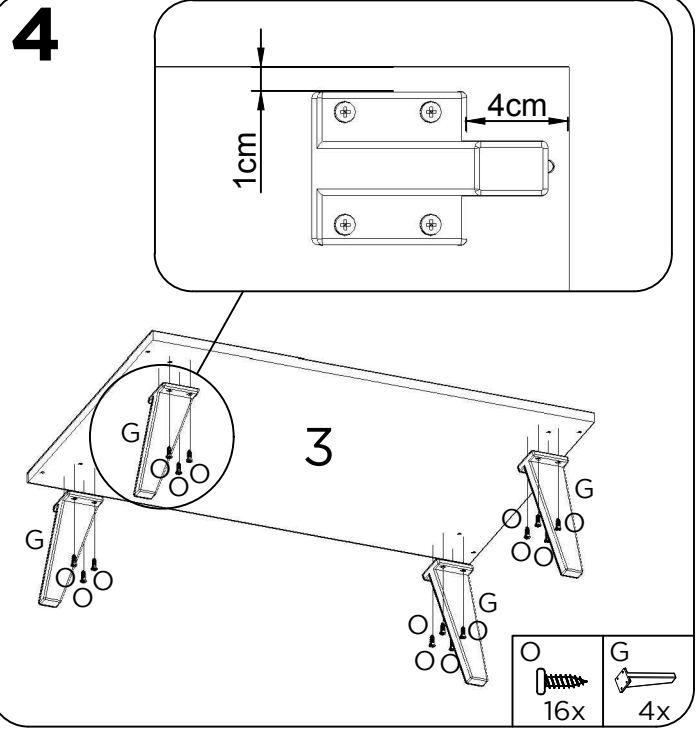
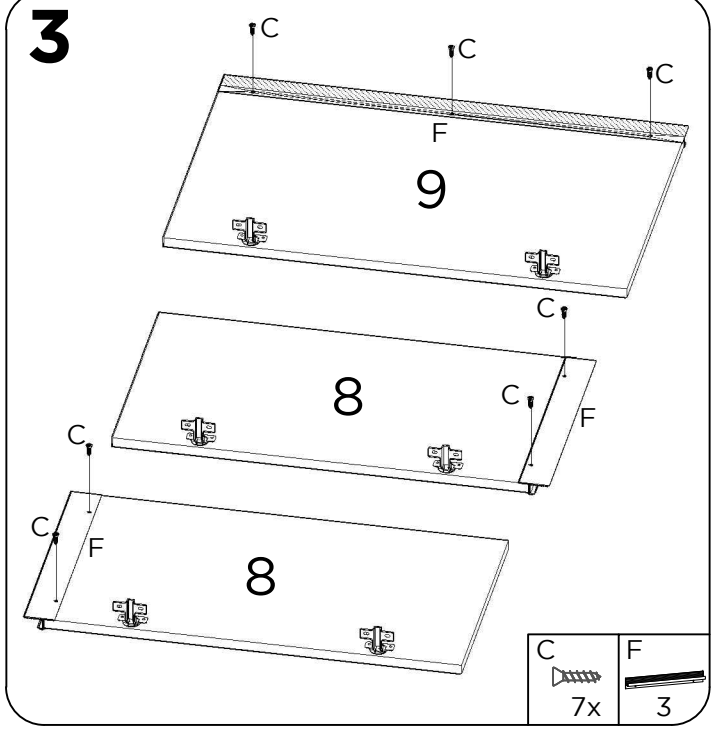
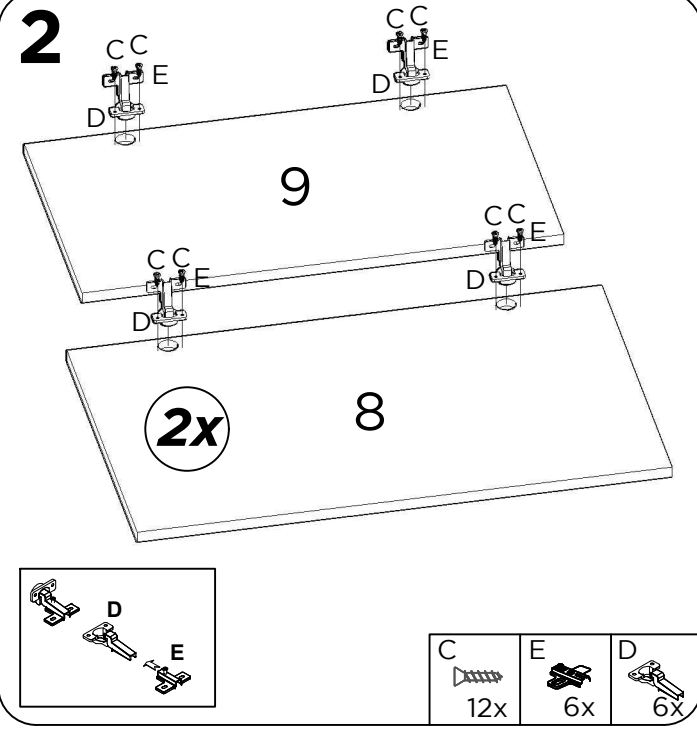
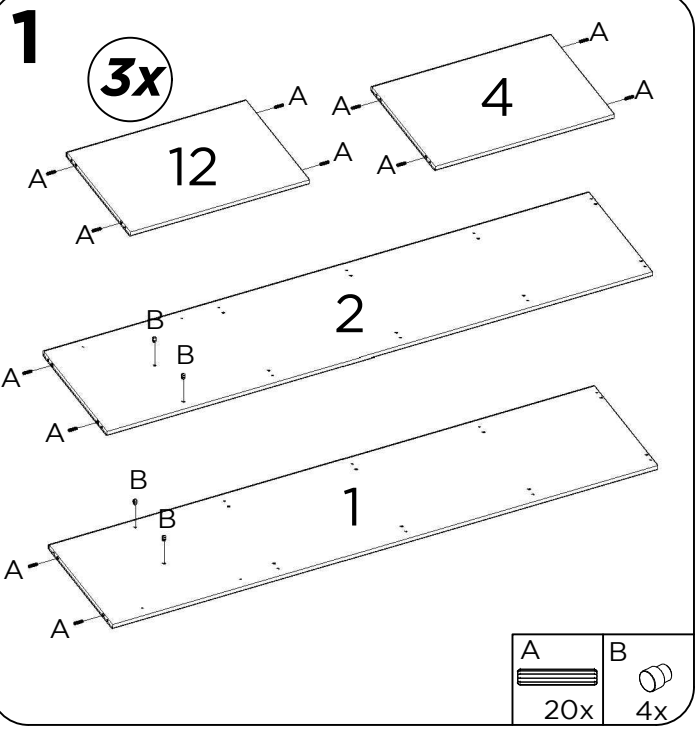

7

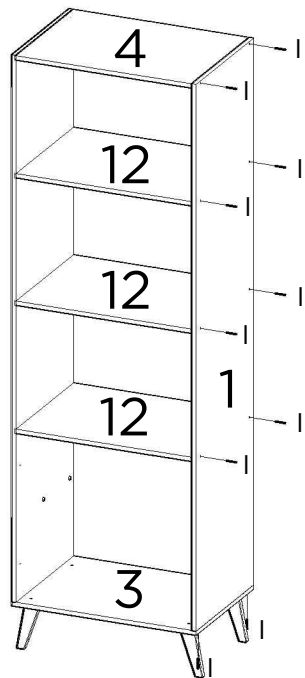

10x

8

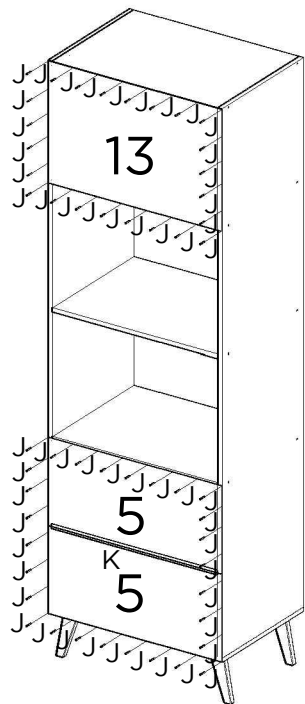
J  
56xK  
1x

9

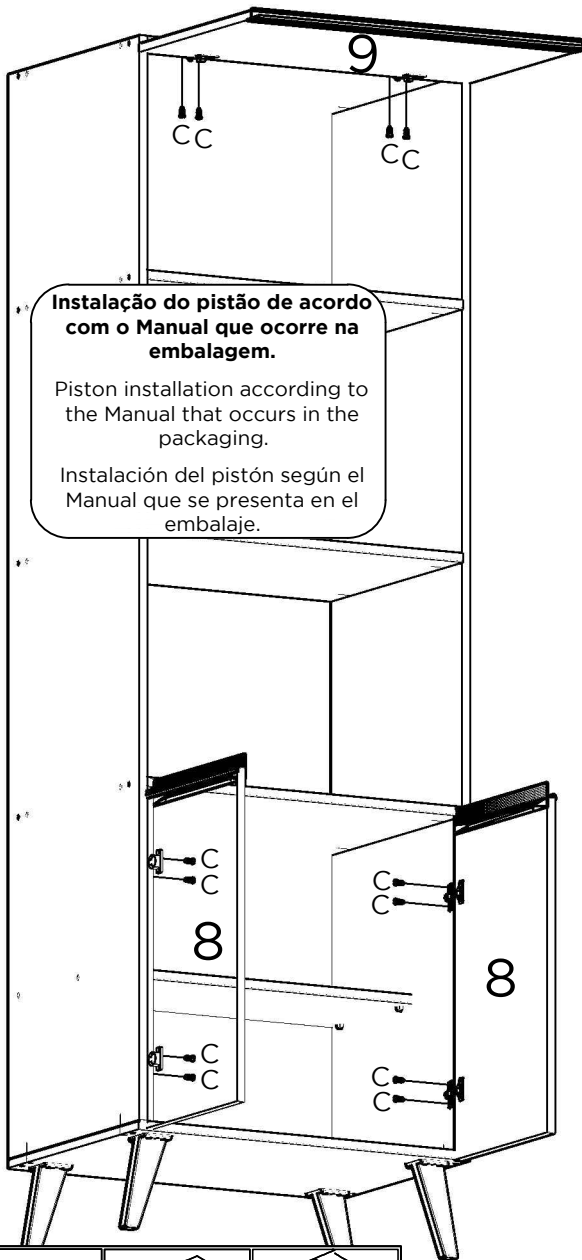

**Instalação do pistão de acordo com o Manual que ocorre na embalagem.**

Piston installation according to the Manual that occurs in the packaging.

Instalación del pistón según el Manual que se presenta en el embalaje.

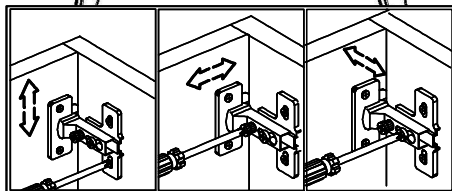
C  
12xQ  
1x

10

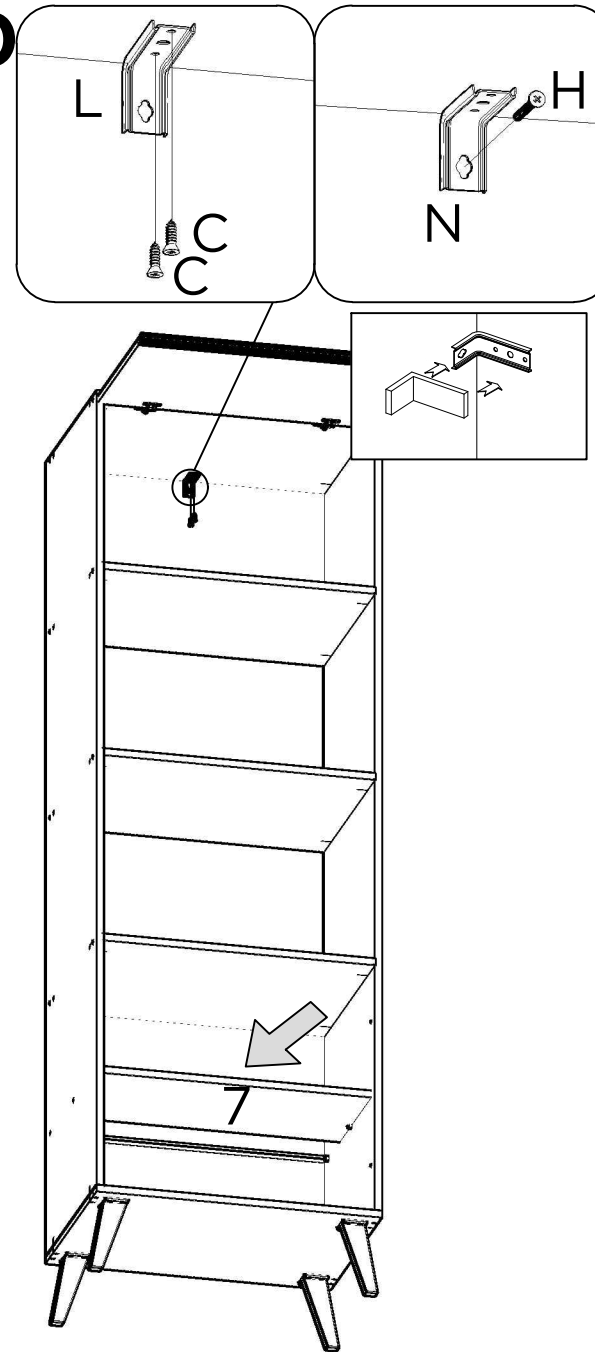
C  
2xM  
1xH  
1xN  
1x

11

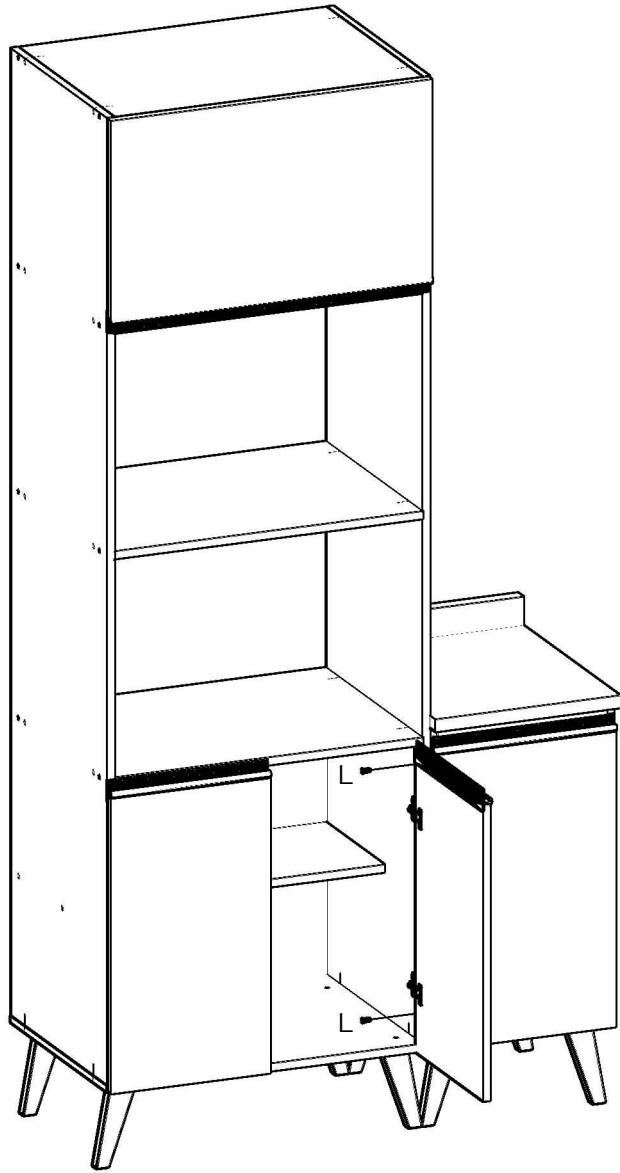

L  
2x

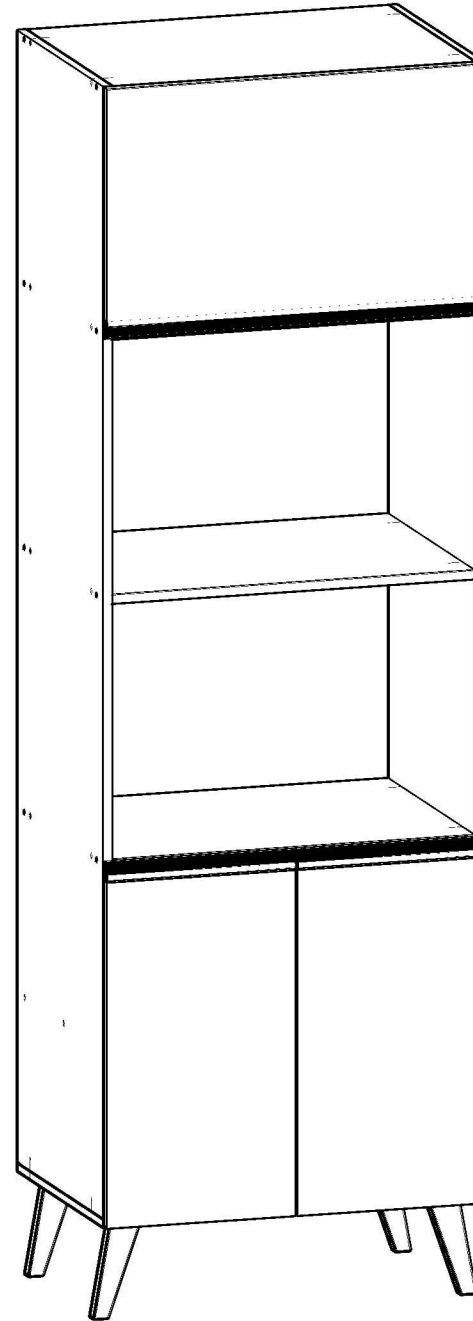

# MANUAL DE MONTAGEM / ASSEMBLY INSTRUCTIONS / PLANO DE ARMADO

**Antes de montar o móvel, leia com atenção o manual de montagem!**  
**Before assembling the furniture, carefully read the assembly instructions!**  
**Antes de armar el mueble, lea con atención el manual de ensamble!**

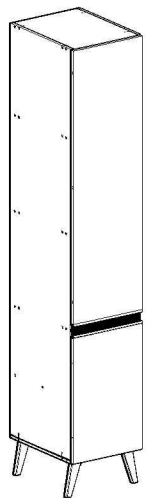

**Ref.: 1252**

**genialflex**  
ambientes incríveis para todos

Parabéns! Você comprou um produto de excelente qualidade, fabricado com chapa de madeira de MDP ou MDF, extraída de florestas renováveis. Possui alta resistência e design atual.

Congratulations! You have purchased a product of excellent quality, made from MDP or MDF wood veneer, extracted from renewable forests. It has high strength and current design.

Felicitaciones! Usted compró a un producto de excelente calidad, fabricado con placa de madera de MDP o MDF, proveniente de florestas renovables. Tiene alta resistencia y diseño actual.



**ATENÇÃO  
ATTENTION  
ATENCIÓN**

- 1) Verifique todas as peças antes de começar a montagem.  
Check all parts before starting assembly.  
Verifique todas las partes antes de empezar el armado.
- 2) Ao começar a montagem, não apoie as peças na parede.  
When starting the assembly, do not support the parts on the wall.  
Al empezar el armado, no apoyes las partes en la pared.
- 3) Ao colocar as peças e ferragens de lado, cuidado para não perde-las.  
When placing parts and hardware aside, be careful not to lose them.  
Al poner las piezas y herrages a parte, cuidado para no dañarlas.
- 4) O móvel deve ser montado no chão, para isso, use a própria caixa para proteger e não danificar o piso.  
The furniture must be mounted on the floor, to do this, use the box itself to protect and not damage the floor.  
El mueble suele ser armado al piso, para eso, use la propia caja para protegerlo y no dañar al piso.
- 5) Comece a montagem seguindo as instruções passo a passo.  
Begin assembly by following the step-by-step instructions.  
Comience el armado siguiendo la instrucciones paso a paso.
- 6) É de responsabilidade do montador seguir as intruções desse manual, que são fundamentais para a estrutura do móvel.  
It's the assembler's responsibility to follow the instructions in this manual, which are fundamental to the structure of the furniture.  
Es de responsabilidad del armador seguir las instrucciones de este manual, que son fundamentales para la estructura del mueble.

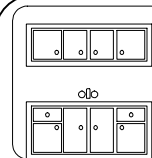

**CUIDADOS  
CARE  
CUIDADO**

- 1) A conservação e limpeza deve ser feita com um pano levemente umedecido com água.  
Care and cleaning should be done with a cloth slightly moistened with water.  
La conservación y limpieza debe ser hecha con un trapo levemente humedecido en agua.
- 2) Não use produtos abrasivos, como saponáceo, detergentes e esponja de aço.  
Do not use abrasive products, such as soap, detergents and steel sponge.  
No use productos abrasivos, como saponáceo, detergentes y esponja de acero.
- 3) Não use cera ou óleo para dar brilho ao móvel.  
Do not use wax or oil to shine the furniture.  
No use cera o aceites para darle brillo al mueble.
- 4) Não expor o móvel a interpéries e nem ao calor excessivo.  
Do not expose the furniture to weather or excessive heat.  
No exponer el mueble a interperies ni al calor excesivo.
- 5) Ao terminar a montagem, limpe o ambiente e o móvel.  
When the assembly is finished, clean the room and the furniture.  
Al terminar el armado, limpie al ambiente y al mueble.

## FERRAMENTAS / TOOLS / HERRAMIENTAS



MARTELO  
HAMMER  
MARTILLO



MARTELO DE BORRACHA  
RUBBER HAMMER  
MARTILLO GOMA

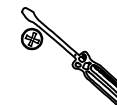

CHAVE PHILLIPS  
PHILLIPS SCREWDRIVER  
LLAVE PHILLIPS









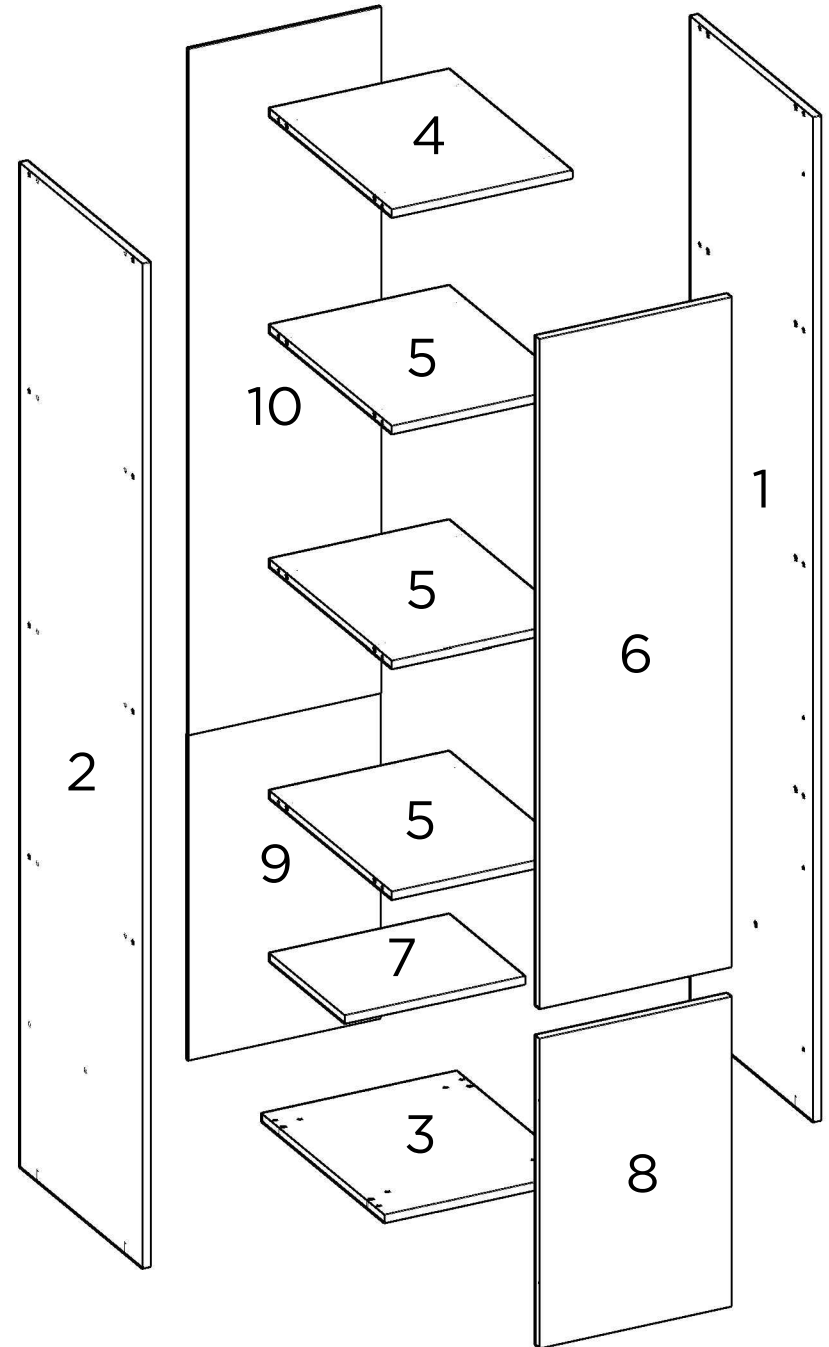



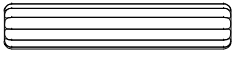

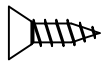

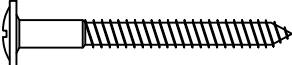
TRENA  
MEASURING TAPE  
CINTA MÉTRICA

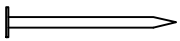
**PEÇAS / PARTS / PIEZAS**

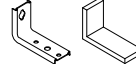
Nº No Num	DESCRIÇÃO DESCRIPTION DESCRIPCIÓN	QTD QTY CANT
1	LATERAL DIREITA RIGHT SIDE PANEL LATERAL DERECHA	1
2	LATERAL ESQUERDA LEFT SIDE PANEL LATERAL IZQUIERDA	1
3	BASE BOTTOM BASE	1
4	TAMPO TOP TABLERO	1
5	PRATELEIRA FIXA FIXED PLATE REPISA FIJO	3
6	PORTA SUPERIOR UPPER DOOR PUERTA SUPERIOR	1
7	PRATELEIRA MÓVEL MOBILE PLATE REPISA MÓVIL	1
8	PORTA DOOR PUERTA	1
9	COSTA INFERIOR LOWER BACK PANEL TRASERO INFERIOR	1
10	COSTA SUPERIOR UPPER BACK PANEL TRASERO SUPERIOR	1

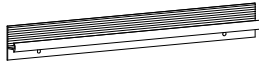

## FERRAGENS / HARDWARE / HERRAJES

CÓD CODE COD	DESCRIÇÃO DESCRIPTION DESCRIPCIÓN	QTD QTY CANT
A	 CABILHA WOODEN DOWEL TARUGO	20
B	 SUPORTE DE PRATELEIRA SHELF SUPPORT SOPORTE DE ESTANTES	4
C	 PARAFUSO 4X14mm SCREW 4X14mm TORNILLO 4X14mm	26
D	 CALÇO PARA DOBRADIÇA HINGE SHED CALZO DE BISAGRA	5
E	 DOBRADIÇA HINGE BIZAGRA	5
F	 PARAFUSO 5X50mm SCREW 5X50mm TORNILLO 5X50mm	1
G	 PÉ LEG PATA	4
H	 PARAFUSO 3,5X40mm SCREW 3,5X40mm TORNILLO 3,5X40mm	20
I	 PREGO NAIL CLAVO	53
J	 GARRA METÁLICA METALLIC CLAW GRAB METALICA	3
K	 SUPORTE DE FIXAÇÃO MOUNTING SUPPORT SOPORTE DE MONTAJE	1
L	 BUCHA PLÁSTICA PLASTIC BUSHING CASQUILLO PLÁSTICO	1
M	 PUXADOR PULLER TIRADOR	2
N	 PARAFUSO 3,5X25mm SCREW 3,5X25mm TORNILLO 3,5X25mm	2
O	 PARAFUSO 4X16mm SCREW 4X16mm TORNILLO 4X16mm	16
P	 TAPA-FURO HOLE COVER TAPA AGUJERO	4

UTILIZE A RÉGUA PARA IDENTIFICAR OS PARAFUSOS  
USE THE RULER TO IDENTIFY THE SCREWS  
UTILICE LA REGLA PARA IDENTIFICAR LOS TORNILLOS

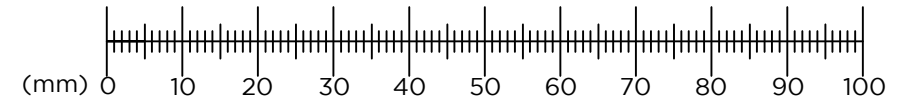

**PESO SUPORTADO / WEIGHT SUPPORTED / PESO SOPORTADO**

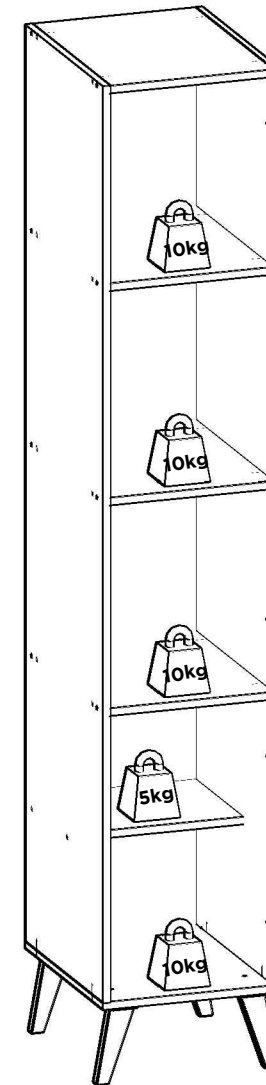

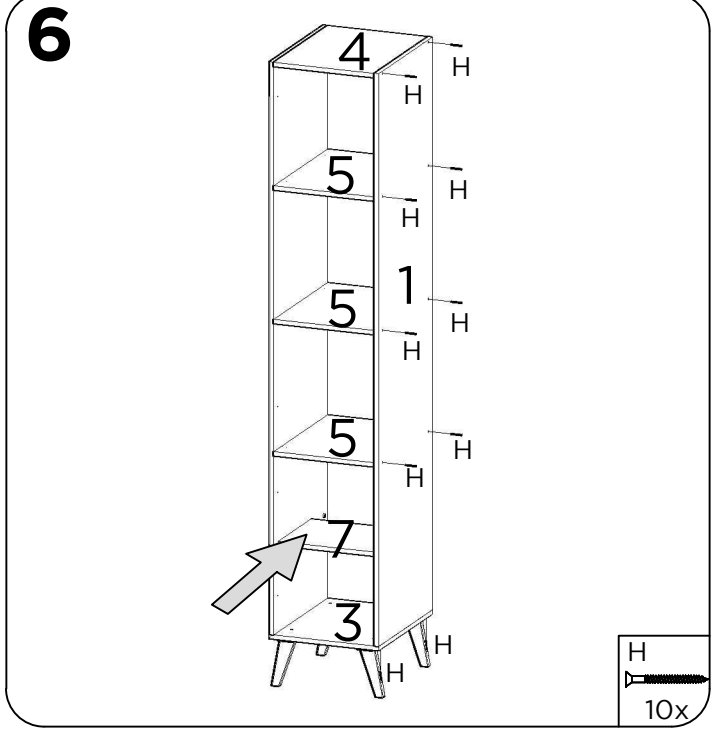
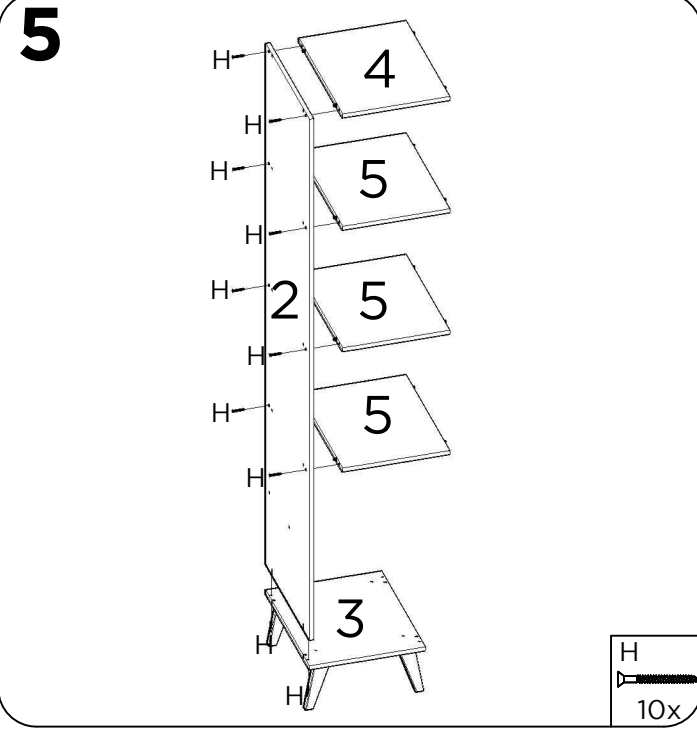
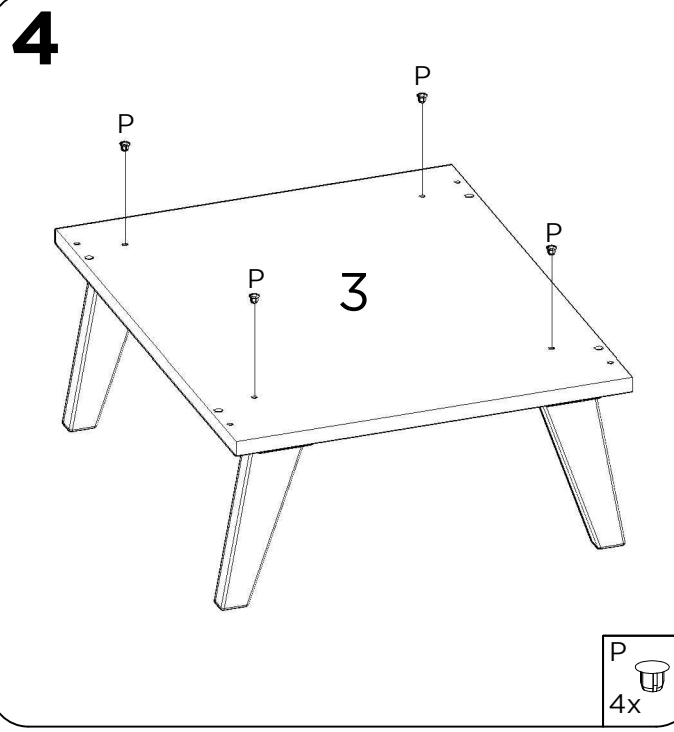
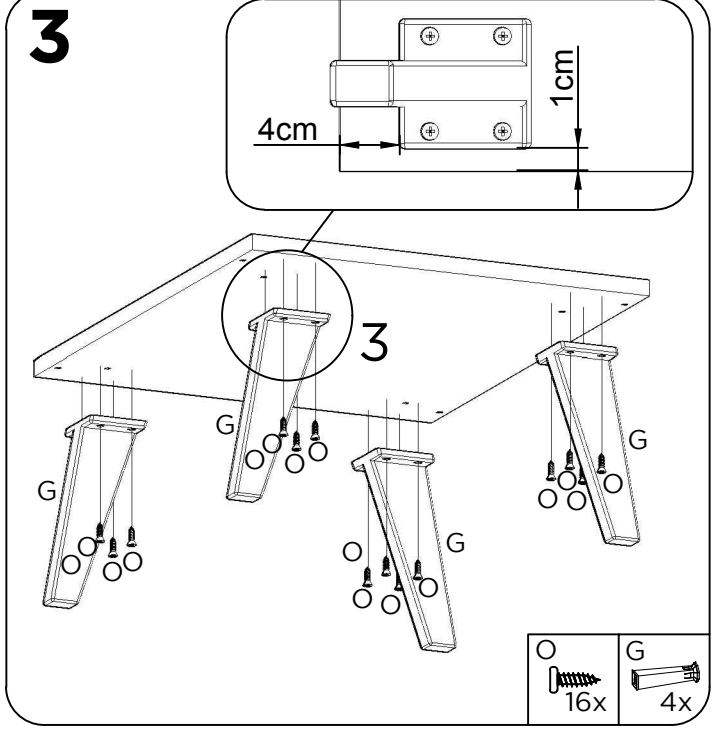
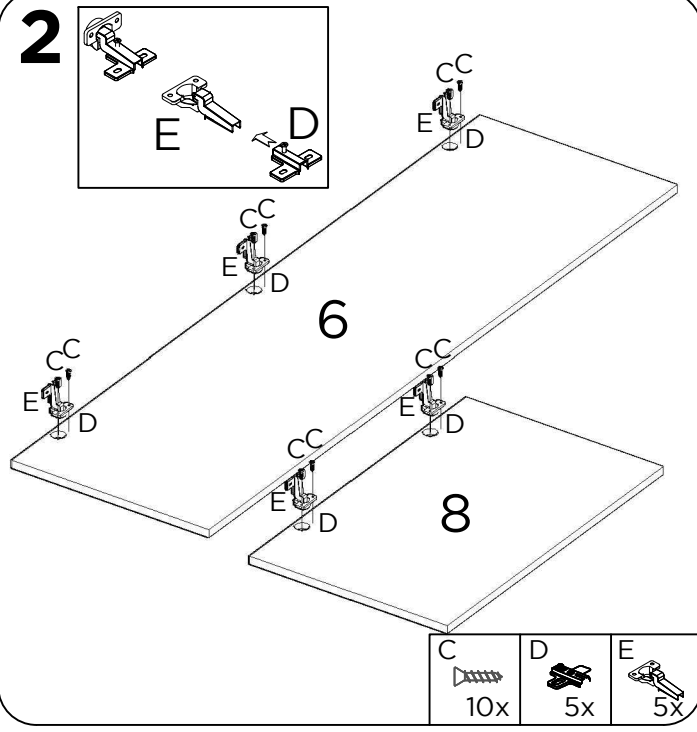
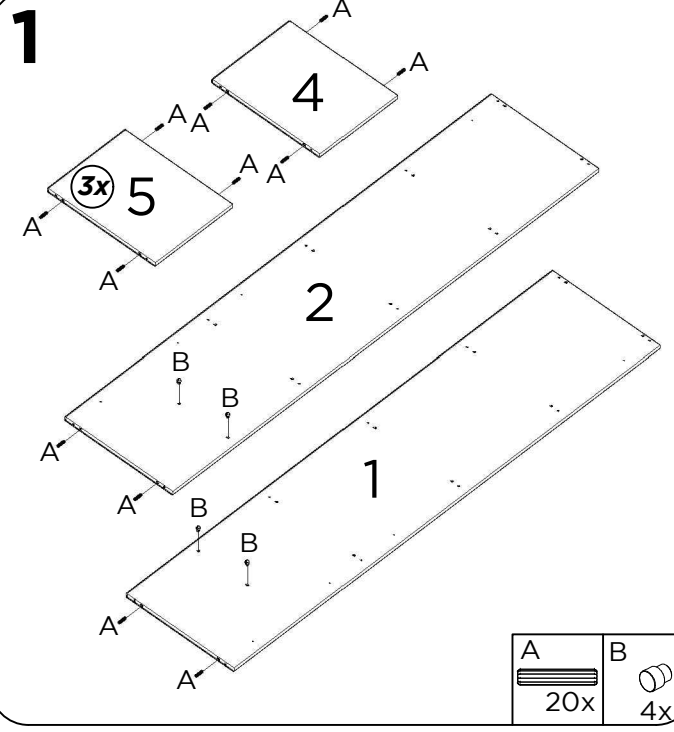

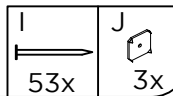
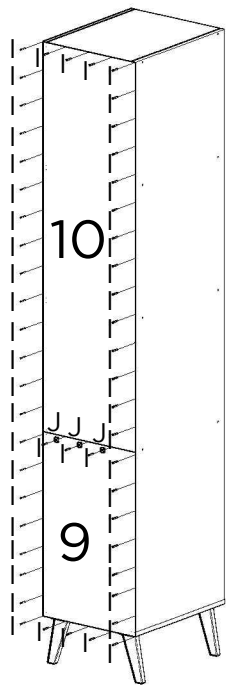
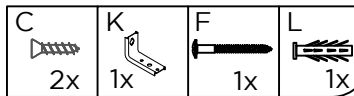
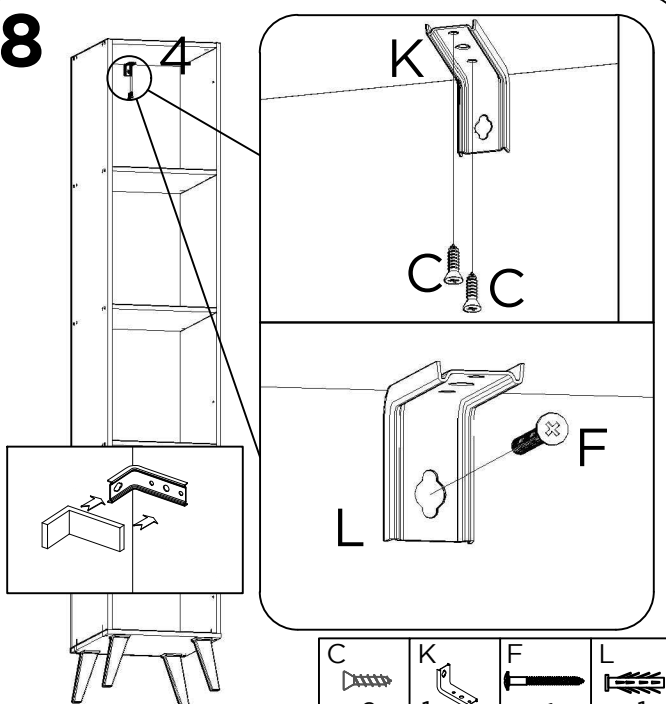
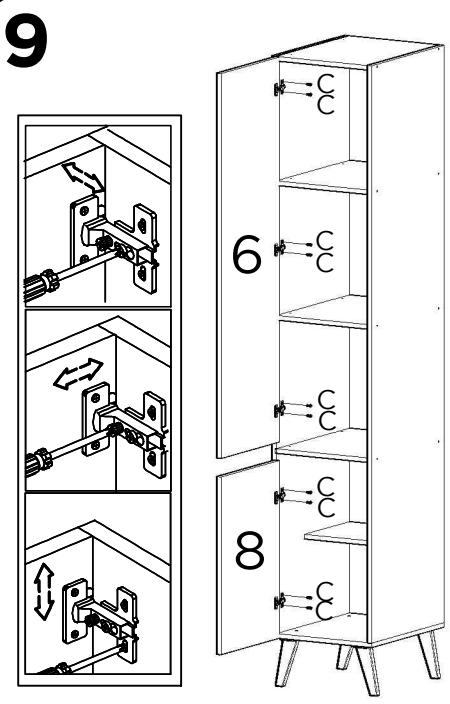
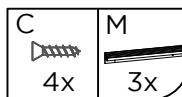
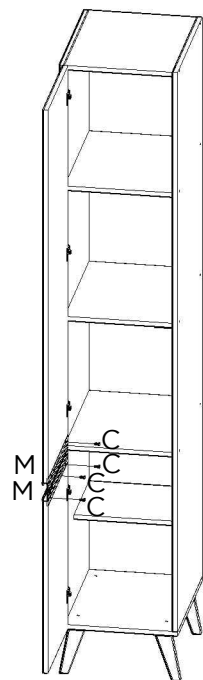
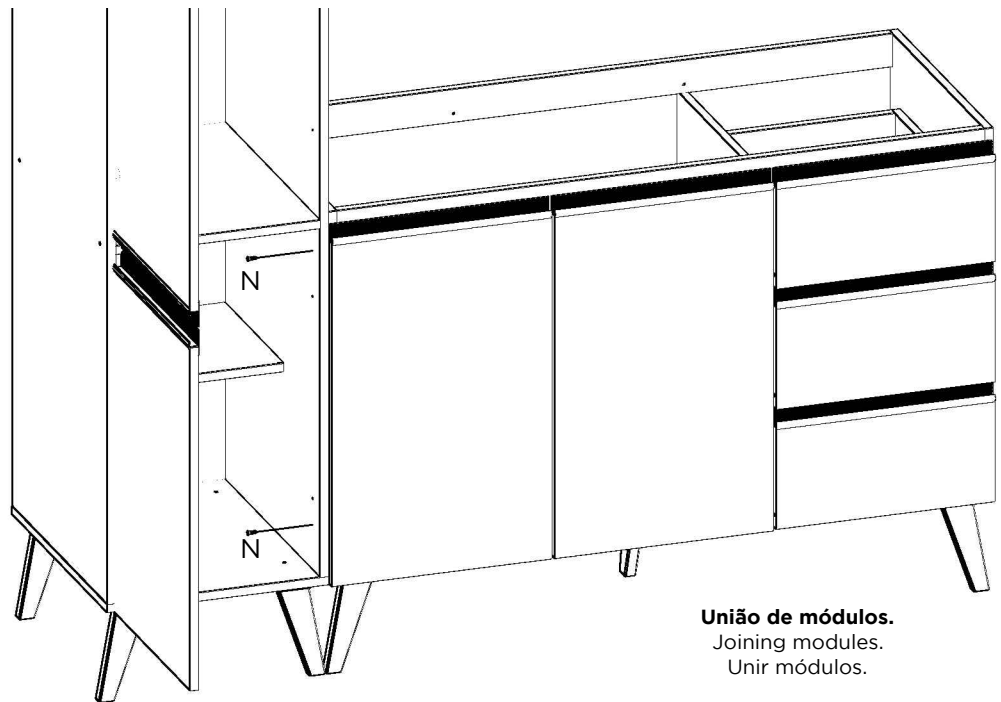
**7****8****9****10****11**

**União de módulos.**  
Joining modules.  
Unir módulos.



# Manual de montagem / Plano de armado

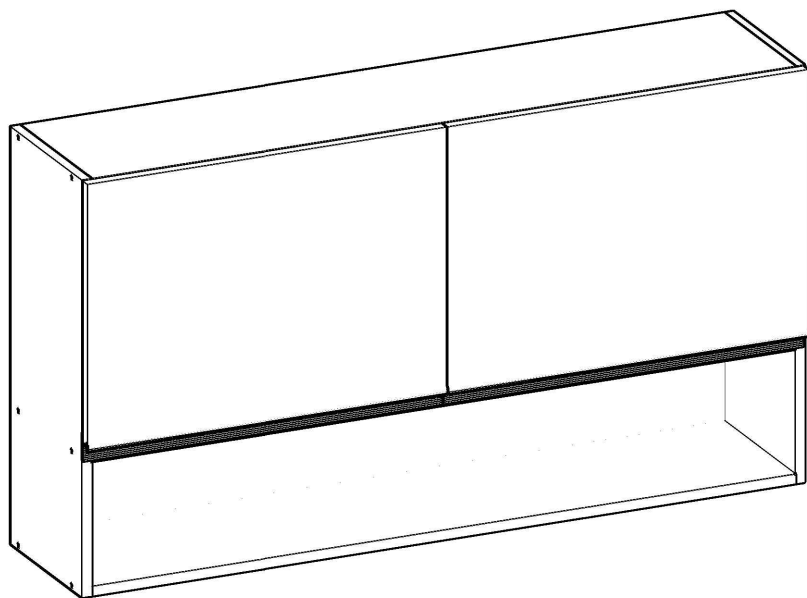

**Ref.: 1202**

**Antes de começar a montagem certifique-se que as caixas estão em perfeitas condições.**

Antes de empezar el armado asegúrese que las cajas estén en perfectas condiciones.



**Parabéns! Você comprou um produto de excelente qualidade, fabricado com chapa de madeira de MDP ou MDF, extraída de florestas renováveis. Possui alta resistência e design atual.**

Felicitaciones! Usted compró a un producto de excelente calidad, fabricado con placa de madera de MDP o MDF, proveniente de florestas renovables. Tiene alta resistencia y diseño actual.

**Antes de montar o móvel, leia com atenção o manual de montagem!**  
**Antes de armar el mueble, lea con atención el manual de ensamble!**



**ATENÇÃO:**  
**ATENCIÓN:**

- 1) Verifique todas as peças antes de começar a montagem.**  
Verifique todas las partes antes de empezar el armado.
- 2) Ao começar a montagem, não apoie as peças na parede.**  
Al empezar el armado, no apoyes las partes en la pared.
- 3) Ao colocar as peças e ferragens de lado, cuidado para não perde-las.**  
Al poner las piezas y herrages a parte, cuidado para no dañarlas.
- 4) O móvel deve ser montado no chão, para isso, use a própria caixa para proteger e não danificar o piso.**  
El mueble suele ser armado al piso, para eso, use la propia caja para protegerlo y no dañar al piso.
- 5) Comece a montagem seguindo as instruções passo a passo.**  
Comience el armado siguiendo la instrucciones paso a paso.
- 6) É de responsabilidade do montador seguir as intruções desse manual, que são fundamentais para a estrutura do móvel.**  
Es de responsabilidad del armador seguir las instrucciones de este manual, que son fundamentales para la estructura del mueble.

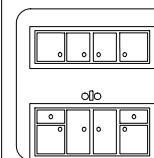

**CUIDADOS:**  
**CUIDADOS:**

- 1) A conservação e limpeza deve ser feita com um pano levemente umedecido com água.**  
La conservación y limpieza debe ser hecha con un trapo levemente humedecido en agua.
- 2) Não use produtos abrasivos, como saponáceo, detergentes e esponja de aço.**  
No use productos abrasivos, como saponáceo, detergentes y esponja de acero.
- 3) Não use cera ou óleo para dar brilho ao móvel.**  
No use cera o aceites para darle brillo al mueble.
- 4) Não expor o móvel a interpéries e nem ao calor excessivo.**  
No exponer el mueble a interperies ni al calor excesivo.
- 5) Ao terminar a montagem, limpe o ambiente e o móvel.**  
Al terminar el armado, limpie al ambiente y al mueble.

**FERRAMENTAS:**  
**HERRAMIENTAS:**

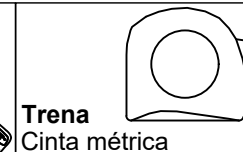

Lista de peças / Lista de piezas		
Nº	Descrição / Descripción	Qtd. Cant.
1	Lateral esquerda / Lateral izquierda	1
2	Lateral direita / Lateral derecha	1
3	Base / Base	2
4	Tampo / Tope	1
5	Porta / Puerta	2
6	Divisória / Divisoria	1
7	Prateleira / Repisa	1
8	Costa inferior / Trasero inferior	1
9	Costa superior / Trasero superior	1

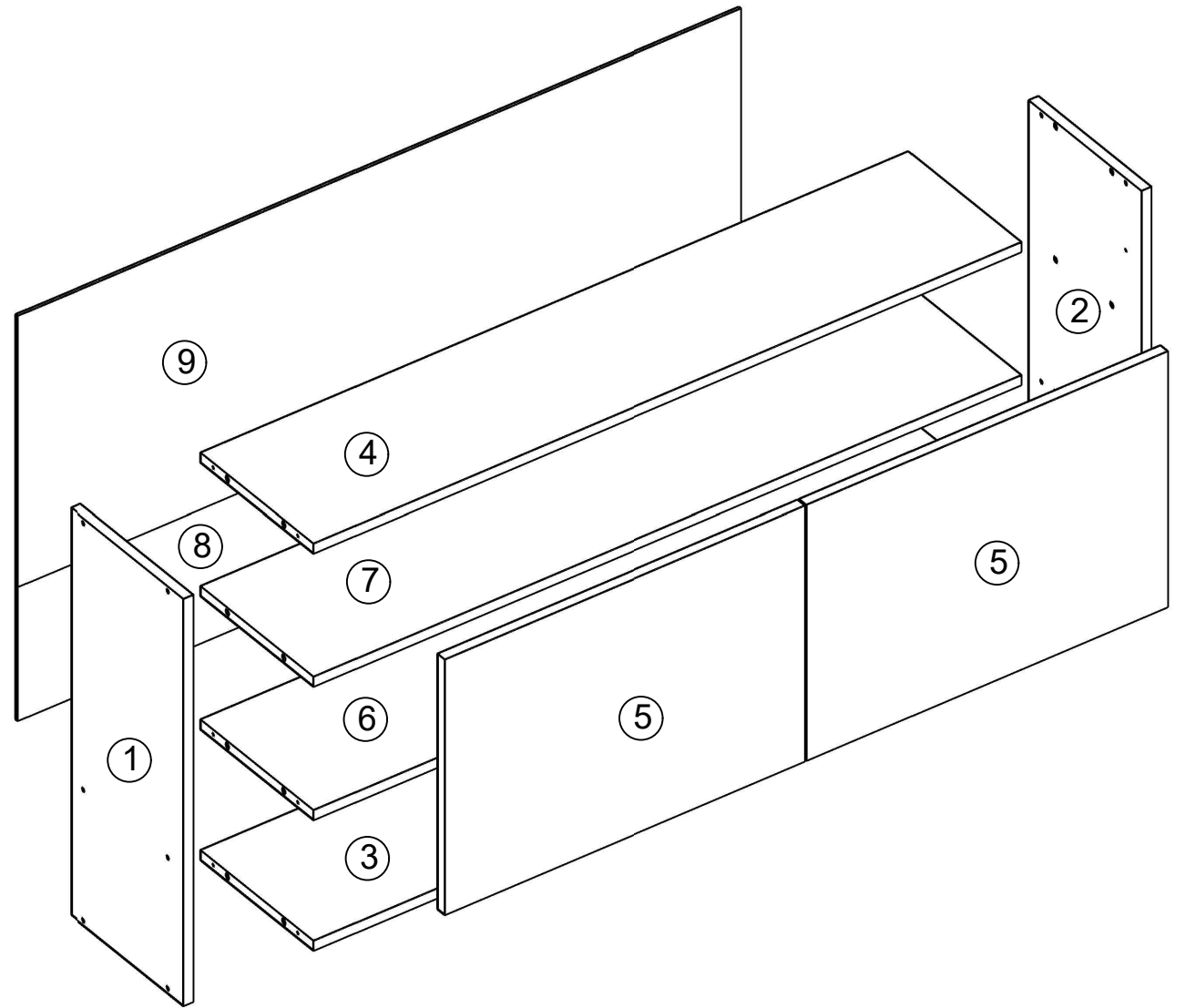

LISTA DE FERRAGENS / LISTA DE HERRAJES

ITEM	DESCRÇÃO / DESCRIPCIÓN	QTD. CANT.
C1	CAVILHAS 8X30 CLAVIJAS 8X30	16
P1	PARAFUSO 4X50 TORNILLO 4X50	12
P2	PARAFUSO 4X14 TORNILLO 4X14	26
P4	PARAFUSO 3,5X25 TORNILLO 3,5X25	2
P5	PARAFUSO 5X50 TORNILLO 5X50	2
D3	CALÇO DE DOBRADIÇA CALZO DE BISAGRA	4
D4	DOBRADIÇA 35mm BISAGRA 35mm	4
R1	PREGO 10X10 CLAVO 10X10	45
GR	GARRA METÁLICA GRAB METALICA	5
U1	PUXADOR TIRADOR	2
S3	SUPORTE DE FIXAÇÃO SOPORTE DE FIJACIÓN	2
CP	CAPA PARA SUPORTE TAPA PARA SOPORTE	2
BA	BUCHA BUSH	2

USE A RÉGUA PARA IDENTIFICAR OS PARAFUSOS  
UTILICE EL REGUA PARA IDENTIFICAR LOS TORNILLOS

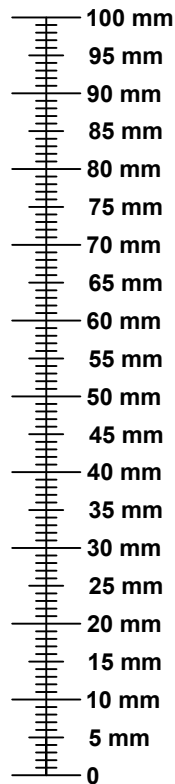

1

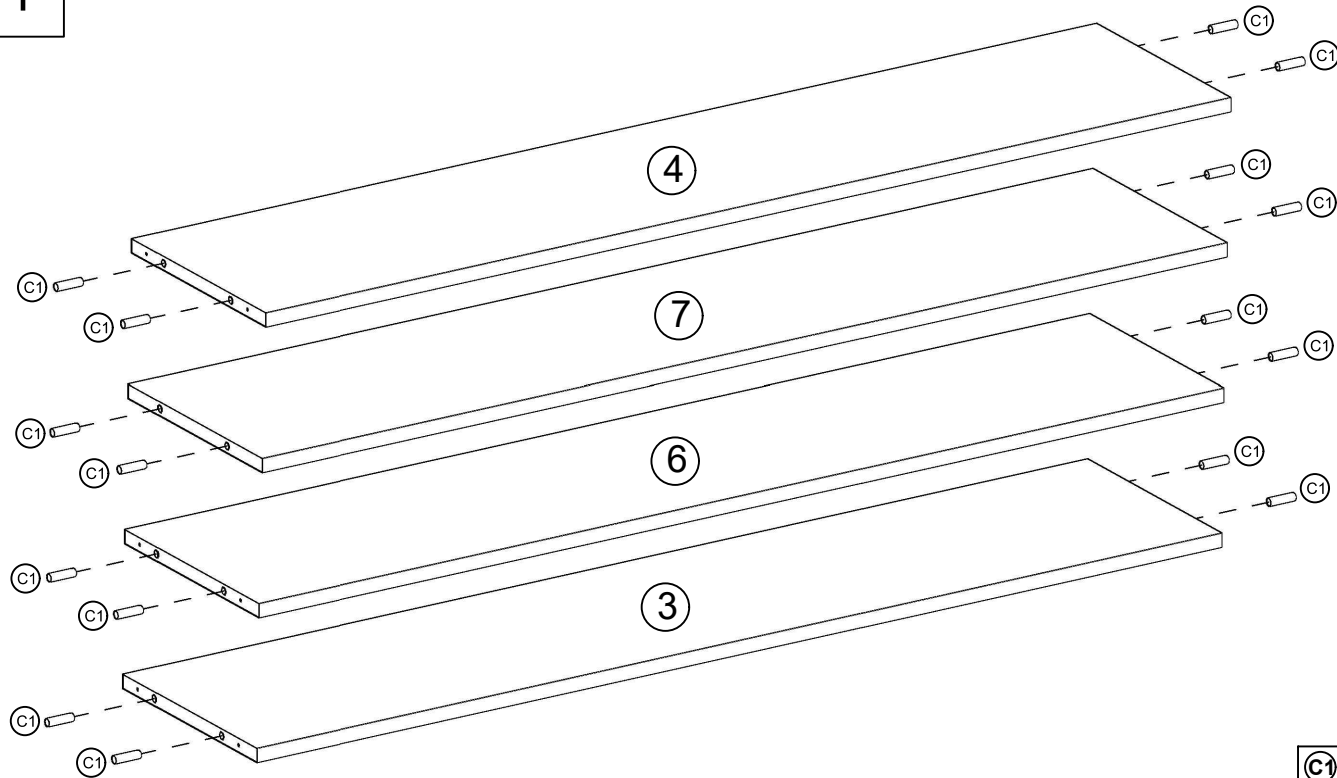

C1  
16X

2

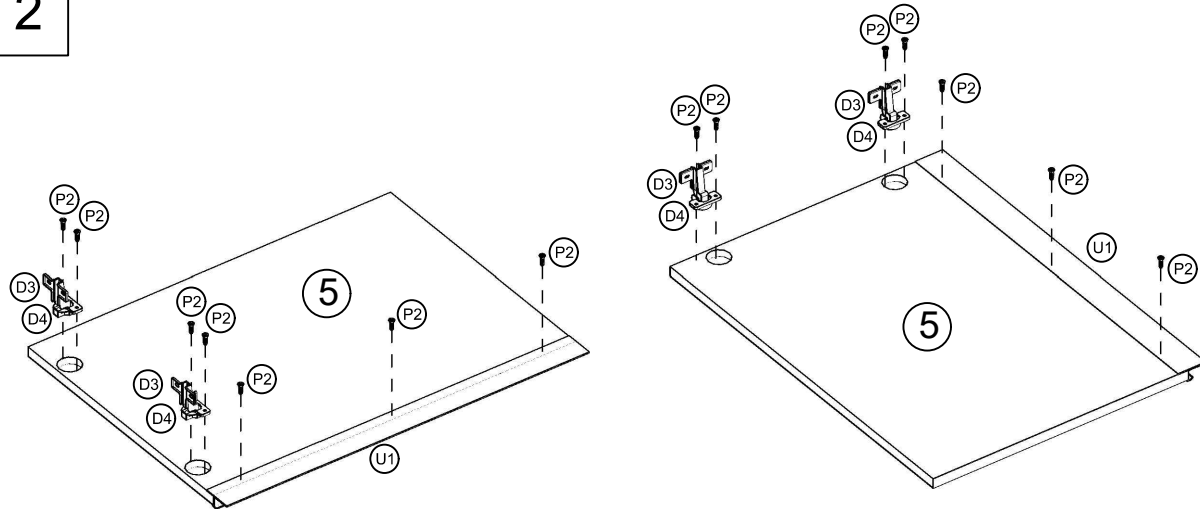

Fixação da peça "D4" na peça "D3", para em seguida fixar o conjunto da dobradiça na porta.

Fijación de la pieza "D4" a la pieza "D3", para en seguida fijar el conjunto de la bisagra en la puerta.

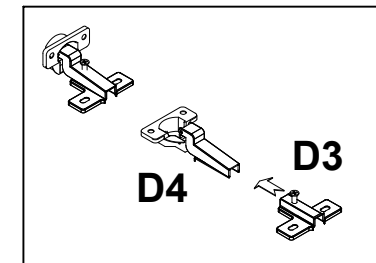

U1 2X  
D4 4X  
D3 4X  
P2 14X

3

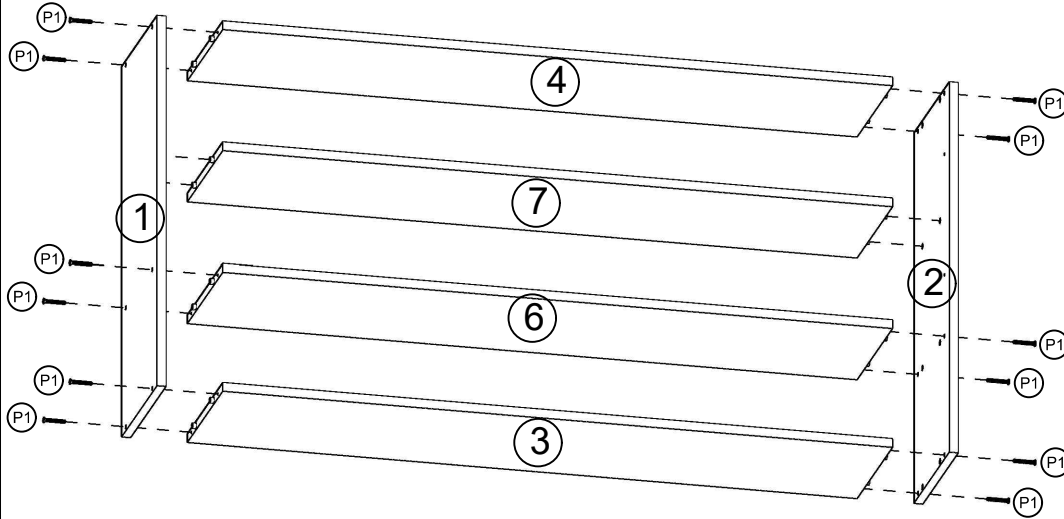

4

COLOQUE AS COSTAS (8 E 9)  
PONGA LOS TRASEROS (8 Y 9)

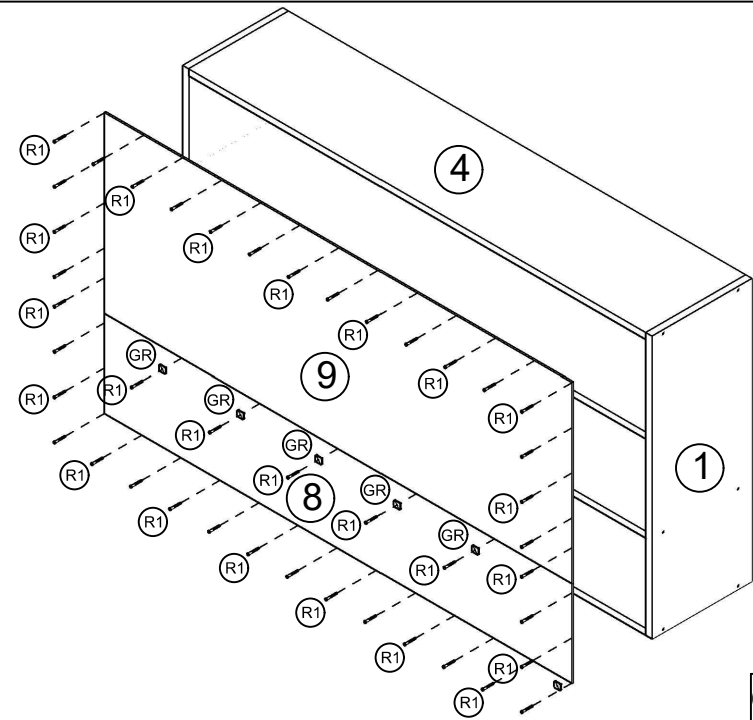

5

**Fixe os suportes de  
fixação nas laterais e no  
tampo do móvel.**

Fije los soportes de fijación  
en las laterales y en el  
tablero del mueble.

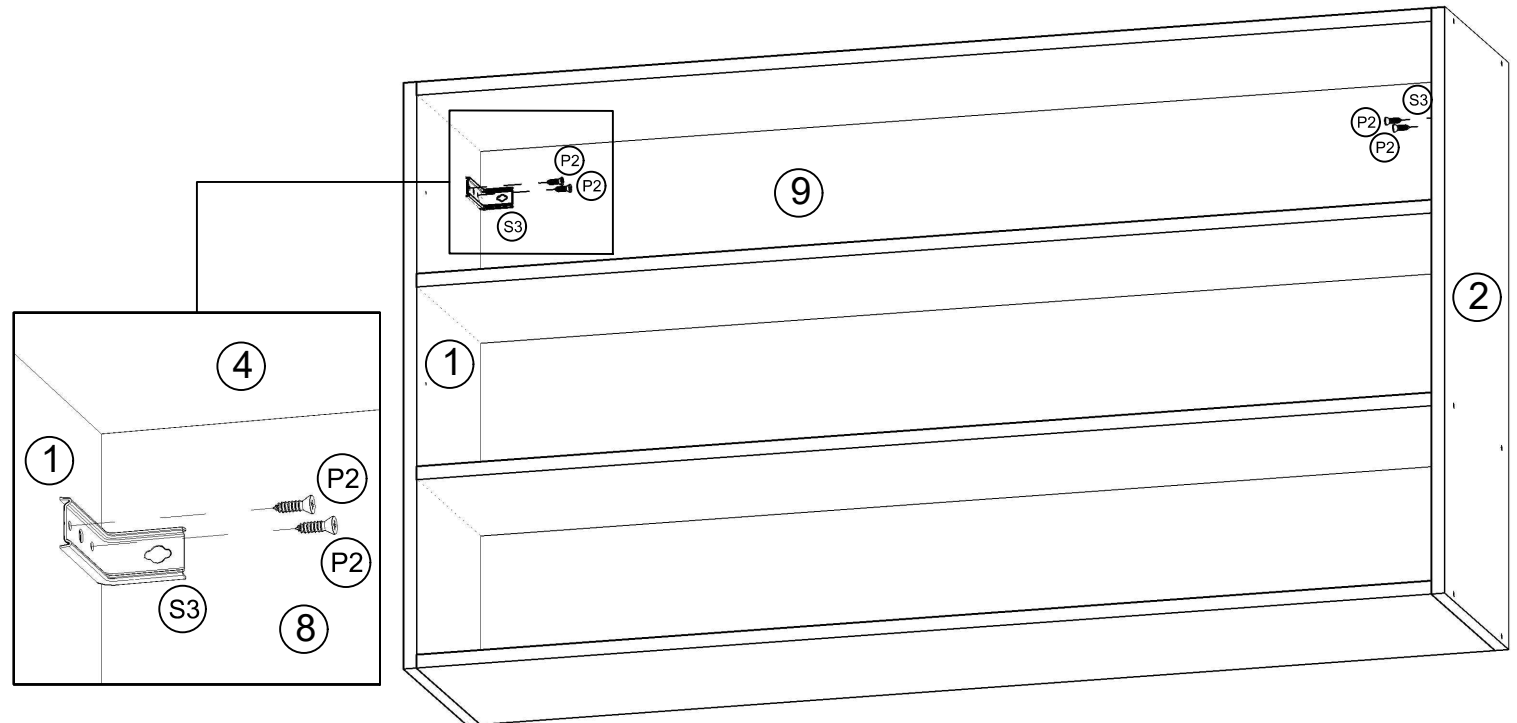

6

**FIXE O MÓVEL NA PAREDE.**

FIJE EL MUEBLE EN LA PARED.

Fixação do móvel na parede através da utilização da bucha "BA" e do parafuso "P5". Depois da fixação fazer uso da capa para suporte "CP".

Fijación del mueble en la pared mediante el uso de la bush "BA" e del tornillo "P5". Después de la fijación hacer uso de la tapa para soporte "CP".

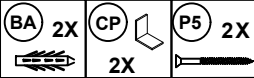
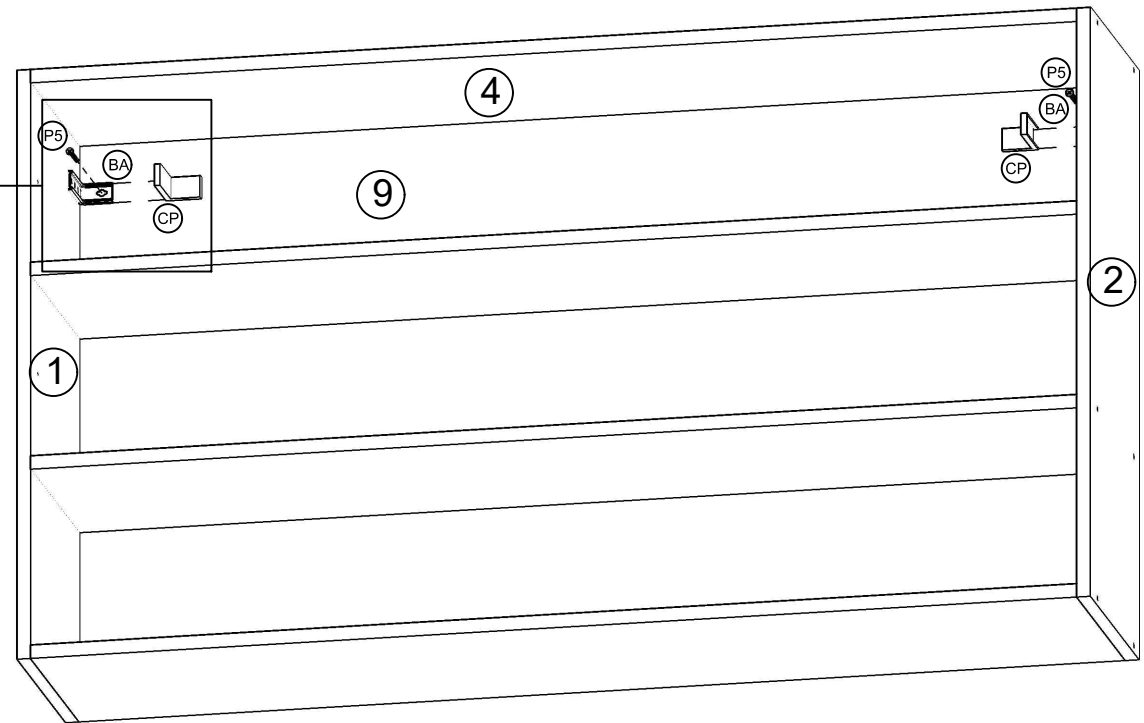
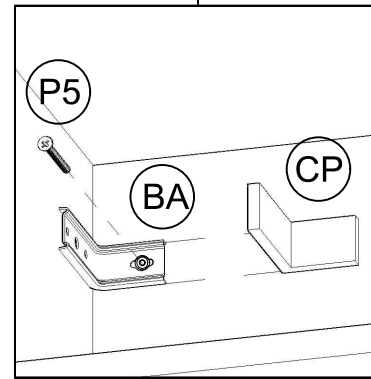

7

**COLOQUE AS PORTAS (6)**  
**PONGA LAS PUERTAS (6)**

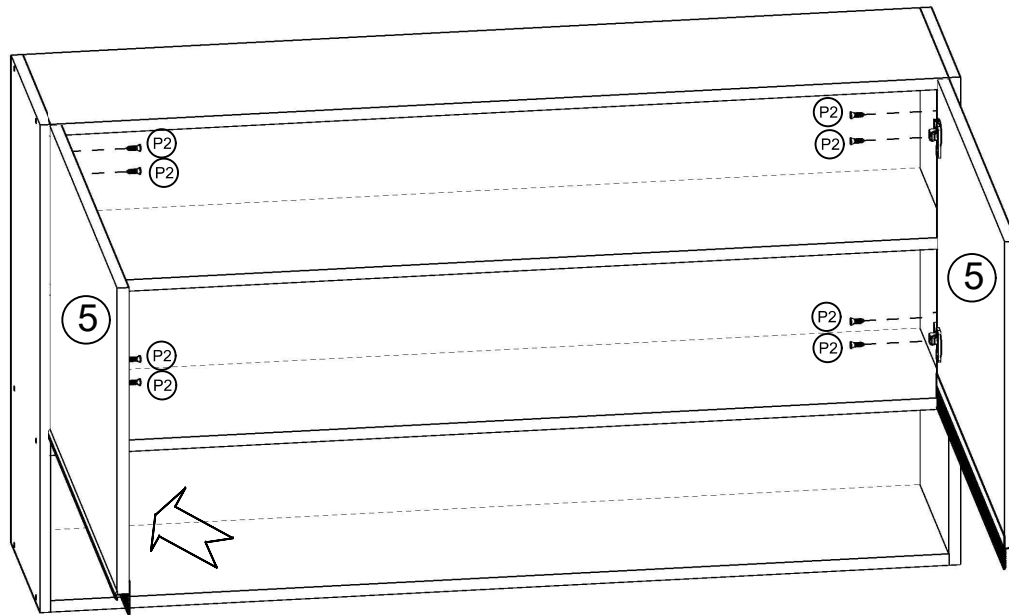

**REGULAGEM DAS PORTAS**  
**AJUSTE DE LAS PUERTAS**

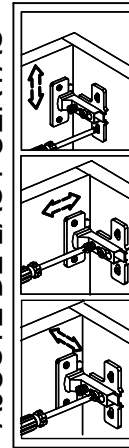

Para realizar a união entre diferentes módulos, fazer uso do parafuso "P4".

Para hacer la unión entre los diferentes módulos, utilice los tornillos "P4".



# MANUAL DE MONTAGEM / ASSEMBLY INSTRUCTIONS / PLANO DE ARMADO

**Antes de montar o móvel, leia com atenção o manual de montagem!**  
**Before assembling the furniture, carefully read the assembly instructions!**  
**Antes de armar el mueble, lea con atención el manual de ensamble!**



**Ref.: 1254**

**genialflex**  
ambientes incríveis para todos

Parabéns! Você comprou um produto de excelente qualidade, fabricado com chapa de madeira de MDP ou MDF, extraída de florestas renováveis. Possui alta resistência e design atual.

Congratulations! You have purchased a product of excellent quality, made from MDP or MDF wood veneer, extracted from renewable forests. It has high strength and current design.

Felicitaciones! Usted compró a un producto de excelente calidad, fabricado con placa de madera de MDP o MDF, proveniente de florestas renovables. Tiene alta resistencia y diseño actual.



**ATENÇÃO**  
**ATTENTION**  
**ATENCIÓN**

- 1)** Verifique todas as peças antes de começar a montagem.  
Check all parts before starting assembly.  
Verifique todas las partes antes de empezar el armado.
- 2)** Ao começar a montagem, não apoie as peças na parede.  
When starting the assembly, do not support the parts on the wall.  
Al empezar el armado, no apoyes las partes en la pared.
- 3)** Ao colocar as peças e ferragens de lado, cuidado para não perde-las.  
When placing parts and hardware aside, be careful not to lose them.  
Al poner las piezas y herrages a parte, cuidado para no dañarlas.
- 4)** O móvel deve ser montado no chão, para isso, use a própria caixa para proteger e não danificar o piso.  
The furniture must be mounted on the floor, to do this, use the box itself to protect and not damage the floor.  
El mueble suele ser armado al piso, para eso, use la propia caja para protegerlo y no dañar al piso.

- 5)** Comece a montagem seguindo as instruções passo a passo.  
Begin assembly by following the step-by-step instructions.  
Comience el armado siguiendo la instrucciones paso a paso.

- 6)** É de responsabilidade do montador seguir as intruções desse manual, que são fundamentais para a estrutura do móvel.  
It's the assembler's responsibility to follow the instructions in this manual, which are fundamental to the structure of the furniture.  
Es de responsabilidad del armador seguir las instrucciones de este manual, que son fundamentales para la estructura del mueble.

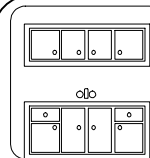

**CUIDADOS**  
**CARE**  
**CUIDADO**

- 1)** A conservação e limpeza deve ser feita com um pano levemente umedecido com água.  
Care and cleaning should be done with a cloth slightly moistened with water.  
La conservación y limpieza debe ser hecha con un trapo levemente humedecido en agua.
- 2)** Não use produtos abrasivos, como saponáceo, detergentes e esponja de aço.  
Do not use abrasive products, such as soap, detergents and steel sponge.  
No use productos abrasivos, como saponáceo, detergentes y esponja de acero.
- 3)** Não use cera ou óleo para dar brilho ao móvel.  
Do not use wax or oil to shine the furniture.  
No use cera o aceites para darle brillo al mueble.
- 4)** Não expor o móvel a interpéries e nem ao calor excessivo.  
Do not expose the furniture to weather or excessive heat.  
No exponer el mueble a interperies ni al calor excesivo.
- 5)** Ao terminar a montagem, limpe o ambiente e o móvel.  
When the assembly is finished, clean the room and the furniture.  
Al terminar el armado, limpie al ambiente y al mueble.

## FERRAMENTAS / TOOLS / HERRAMIENTAS



MARTELO  
HAMMER  
MARTILLO



MARTELO DE BORRACHA  
RUBBER HAMMER  
MARTILLO GOMA

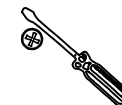

CHAVE PHILLIPS  
PHILLIPS SCREWDRIVER  
LLAVE PHILLIPS









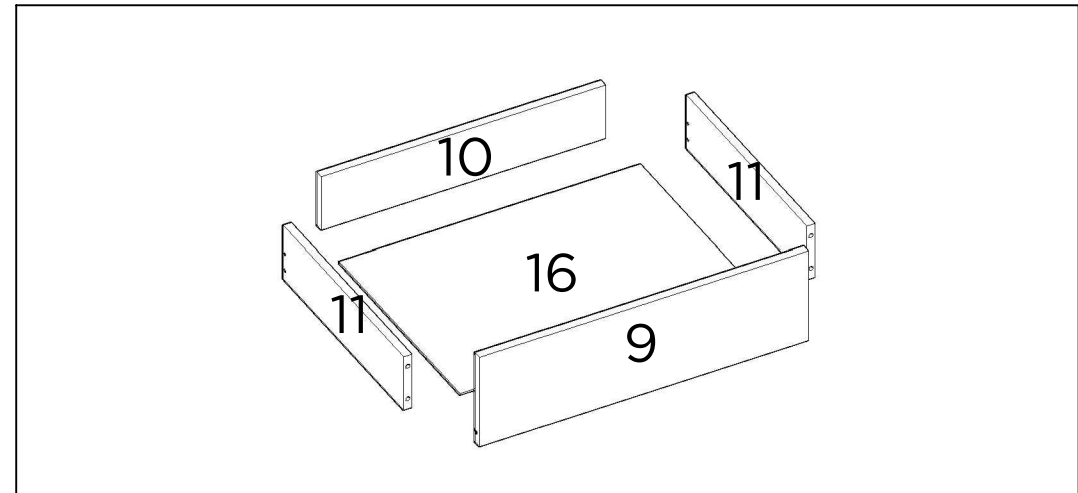
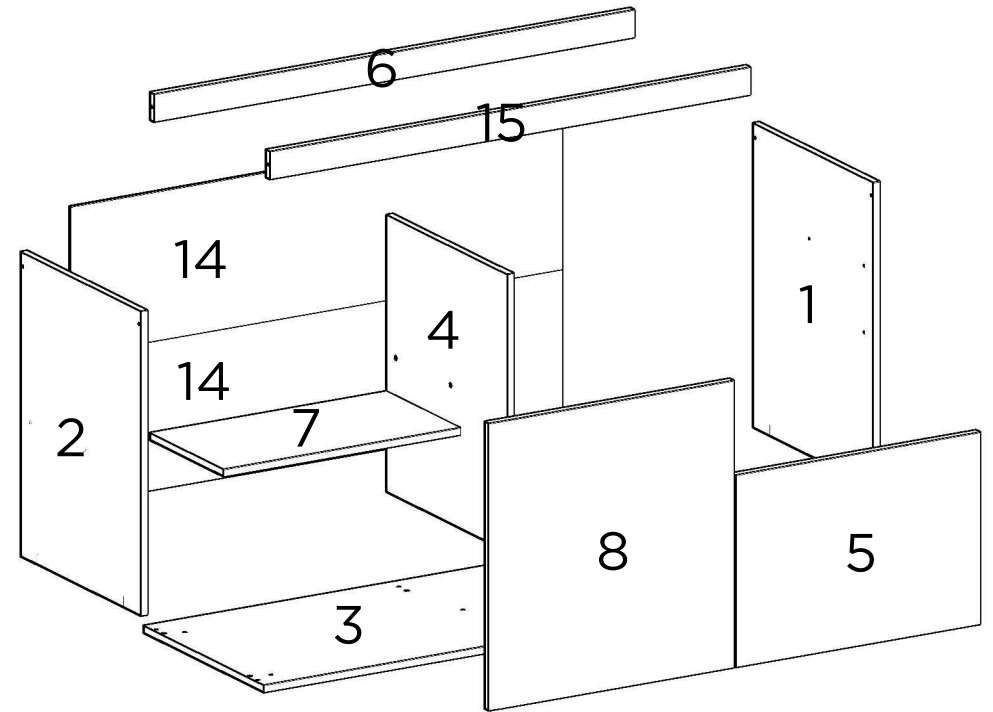



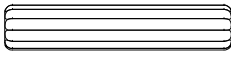





TRENA  
MEASURING TAPE  
CINTA MÉTRICA

**PEÇAS / PARTS / PIEZAS**

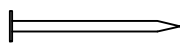
<b>Nº No Num</b>	<b>DESCRIÇÃO DESCRIPTION DESCRIPCIÓN</b>	<b>QTD QTY CANT</b>
1	LATERAL DIREITA RIGHT SIDE PANEL LATERAL DERECHA	1
2	LATERAL ESQUERDA LEFT SIDE PANEL LATERAL IZQUIERDA	1
3	BASE BOTTOM BASE	1
4	DIVISÓRIA DIVISION DIVISIÓN	1
5	PORTA MENOR MINOR DOOR PUERTA MENOR	1
6	TRAVESSA TRASEIRA BACK PLATE TRAVESAÑO TRASERO	1
7	PRATELEIRA PLATE PANEL REPISA	1
8	PORTA MAIOR BIGGER DOOR PUERTA MAJOR	1
9	FRENTE DE GAVETA DRAWER FRONT FRENTE DEL CAJÓN	1
10	COSTA DE GAVETA DRAWER BACK TRASERO DEL CAJÓN	1
11	LATERAL DE GAVETA DRAWER SIDE LATERAL DEL CAJÓN	2
14	COSTA BACK PANEL TRASERO	2
15	TRAVESSA FRONTAL FRONTAL PLATE TRAVESAÑO FRONTAL	1
16	FUNDO DE GAVETA DRAWER BOTTOM PANEL FONDO DEL CAJÓN	1

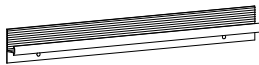

## FERRAGENS / HARDWARE / HERRAJES

CÓD CODE COD	DESCRIÇÃO DESCRIPTION DESCRIPCIÓN	QTD QTY CANT
A	 CAVILHA WOODEN DOWEL TARUGO	10
B	 SUPORTE DE PRATELEIRA SHELF SUPPORT SOPORTE DE ESTANTES	4
C	 PARAFUSO 4X14mm SCREW 4X14mm TORNILLO 4X14mm	40
D	 LATERAL GAVETA CORREDIÇA SLIDE CORREDERA	1
E	 DOBRADIÇA HINGE BIZAGRA	4
F	 CALÇO PARA DOBRADIÇA HINGE SHED CALZO DE BISAGRA	4
H	 PÉ LEG PATA	5
I	 PARAFUSO 3,5X40mm SCREW 3,5X40mm TORNILLO 3,5X40mm	10
J	 CANTONEIRA DE 2 FUROS METALLIC ANGLE CANTONERA 2 AGUJEROS	2
K	 PARAFUSO 3,5X25mm SCREW 3.5X25mm TORNILLO 3.5X25mm	4
L	 PREGO NAIL CLAVO	52
M	 PERFIL I PROFILE I PERFIL I	1
N	 CANTONEIRA DE 4 FUROS METALLIC ANGLE CANTONERA 4 AGUJEROS	2
O	 PREGO ANELADO RINGED NAIL CLAVO ANILLADO	4
P	 PUXADOR PULLER TIRADOR	3
Q	 PARAFUSO 4X16mm SCREW 4X16mm TORNILLO 4X16mm	20
R	 TAPA-FURO HOLE COVER TAPA AGUJERO	5

UTILIZE A RÉGUA PARA IDENTIFICAR OS PARAFUSOS  
USE THE RULER TO IDENTIFY THE SCREWS  
UTILICE LA REGLA PARA IDENTIFICAR LOS TORNILLOS

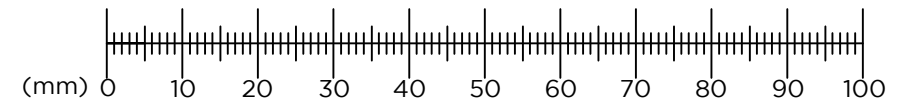

**PESO SUPORTADO / WEIGHT SUPPORTED / PESO SOPORTADO**

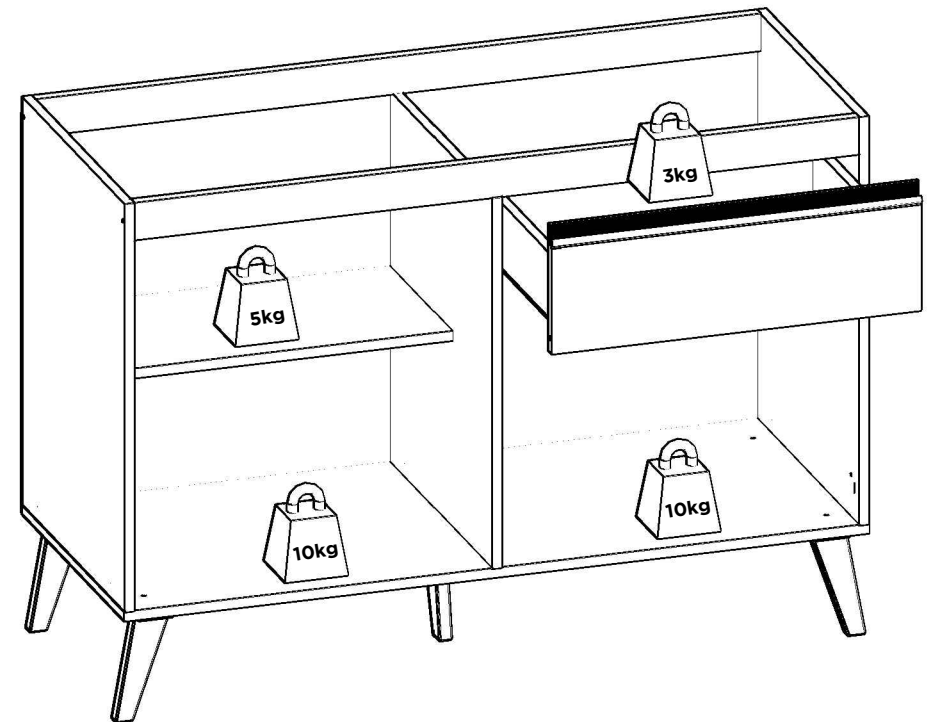

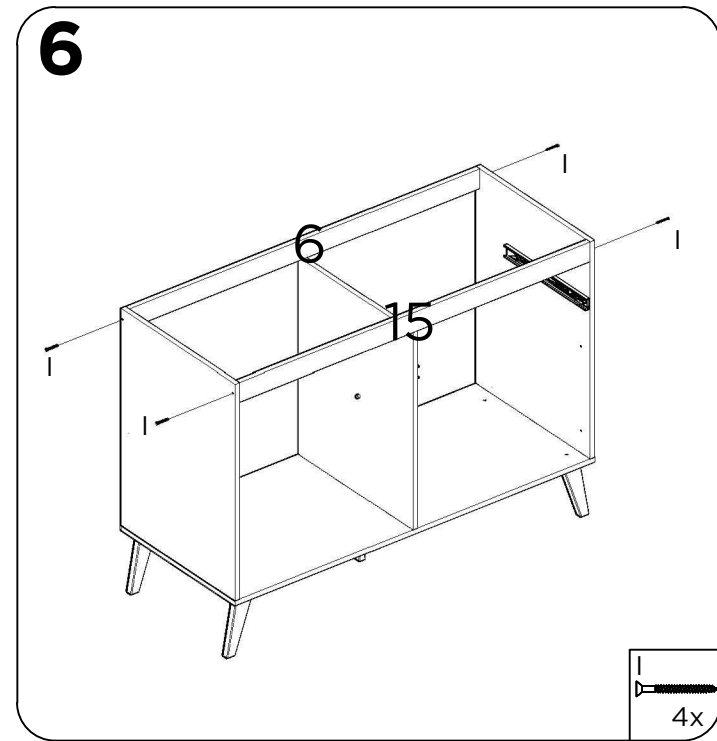
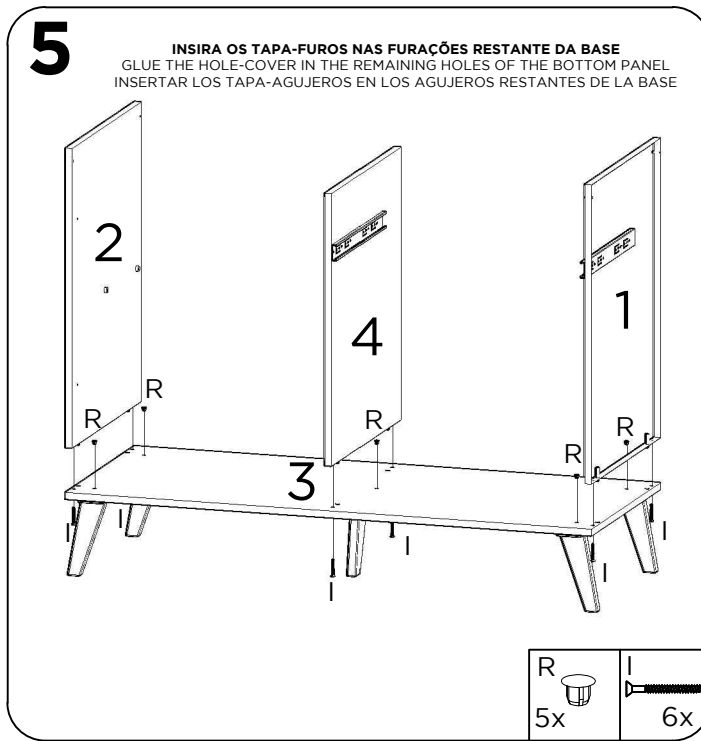
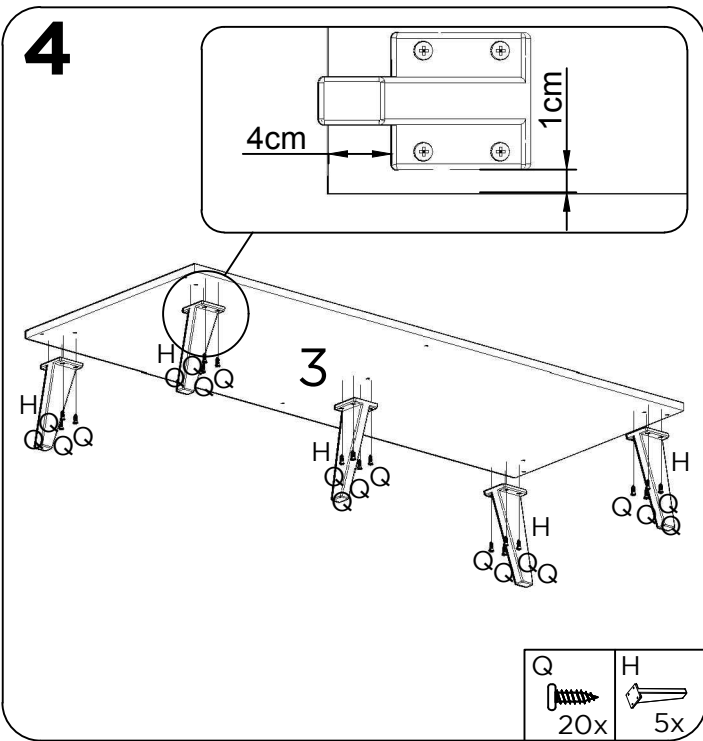
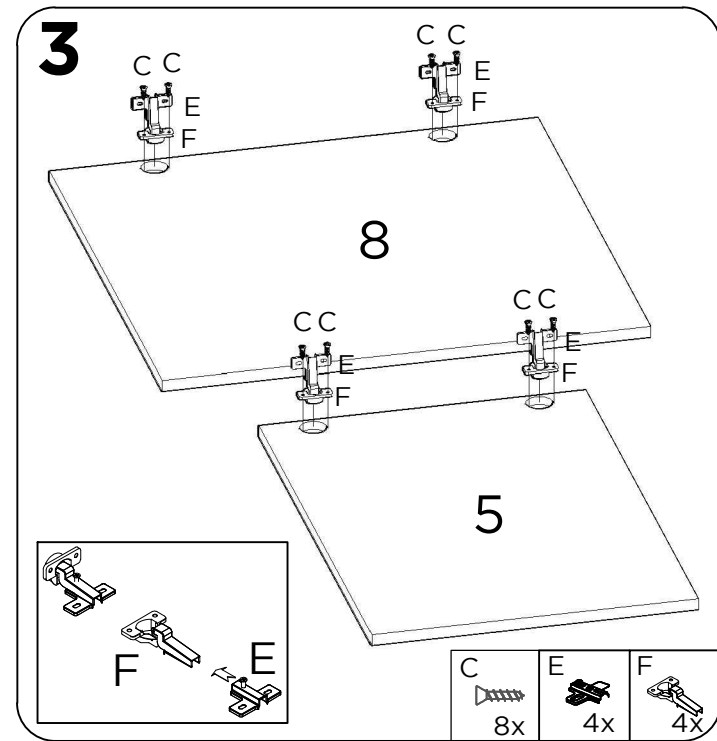
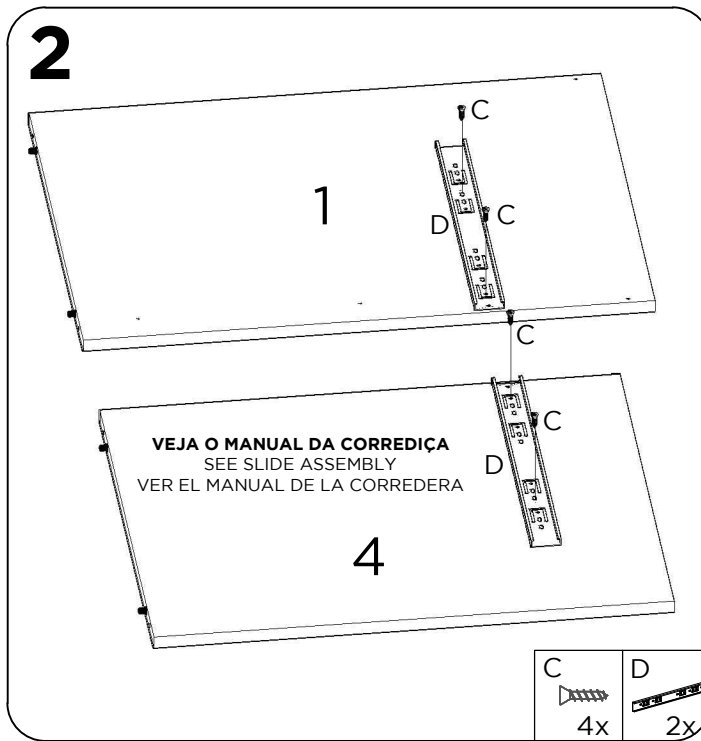
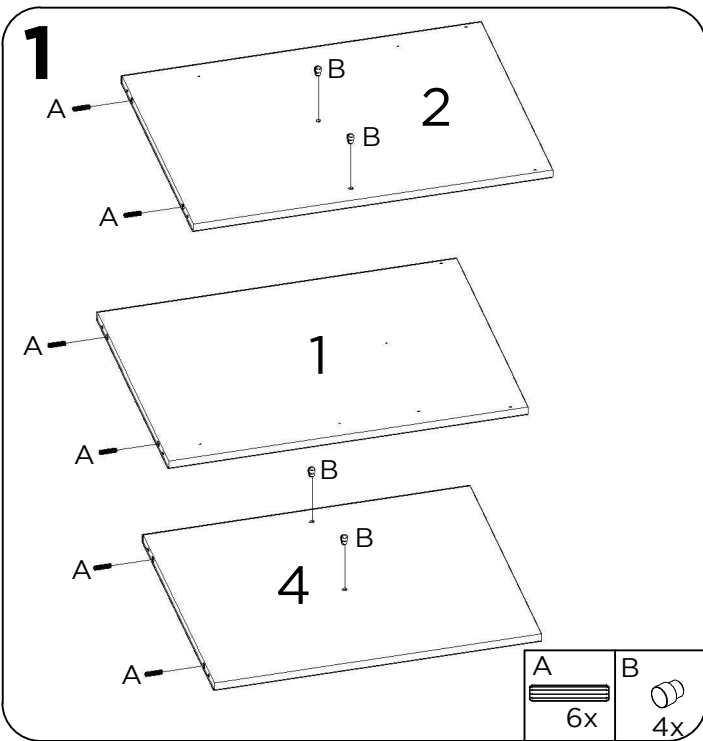

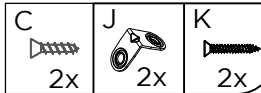
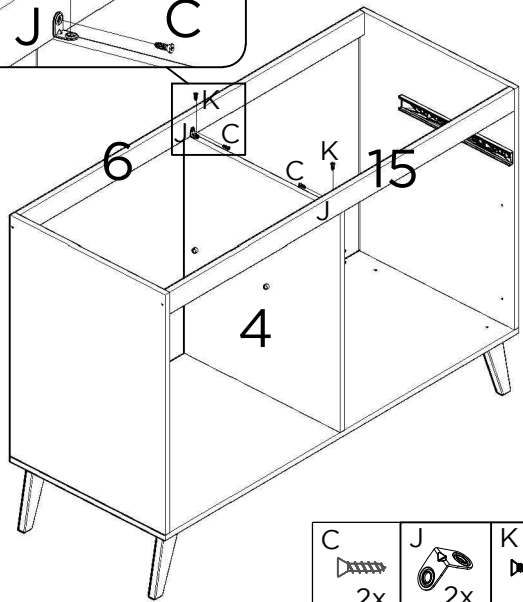
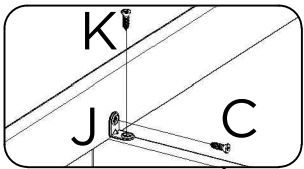
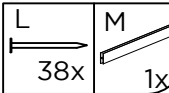
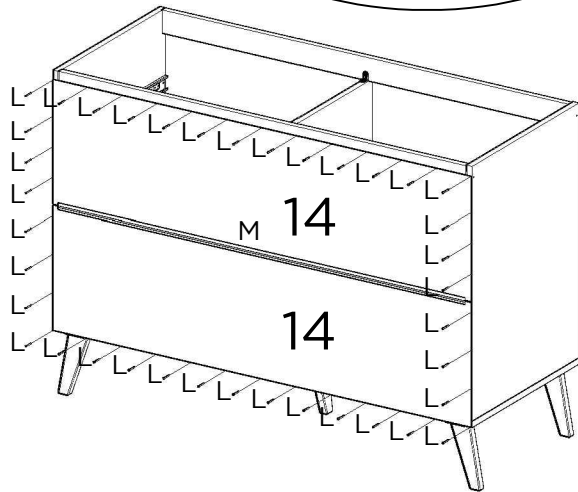
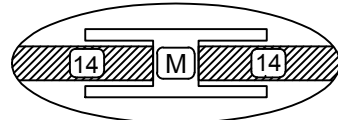
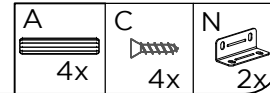
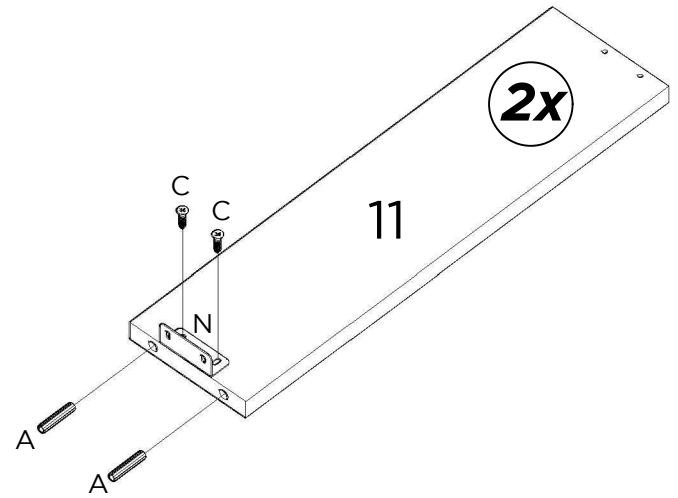
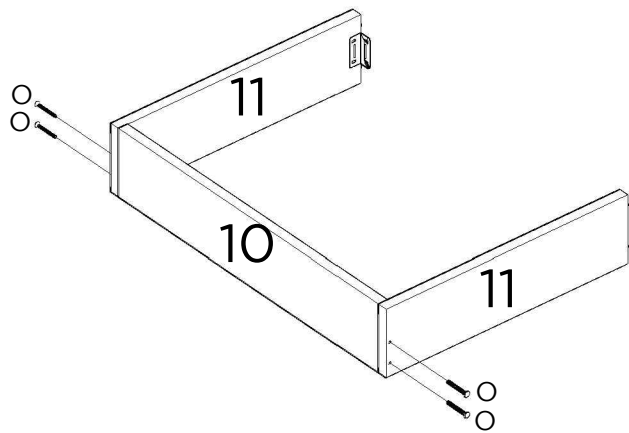
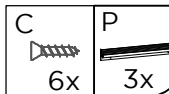
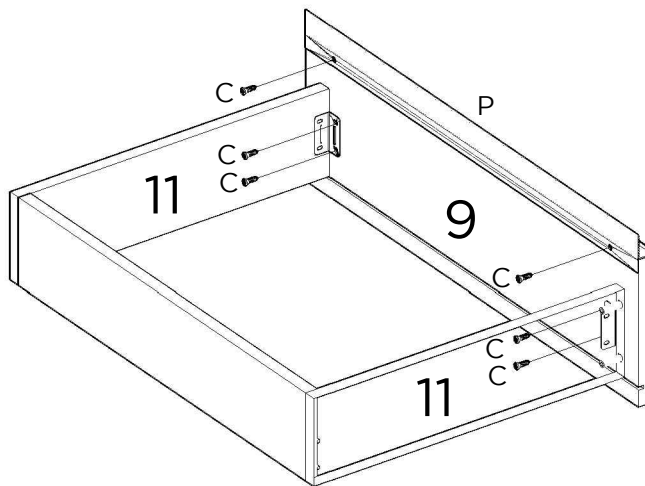
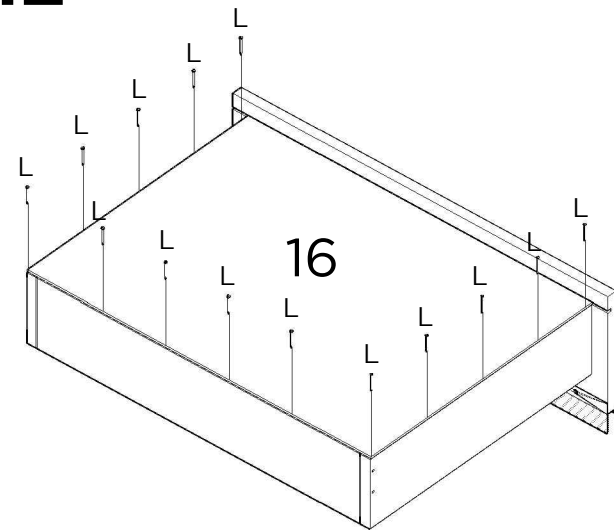
**7****8****9****10****11****12**

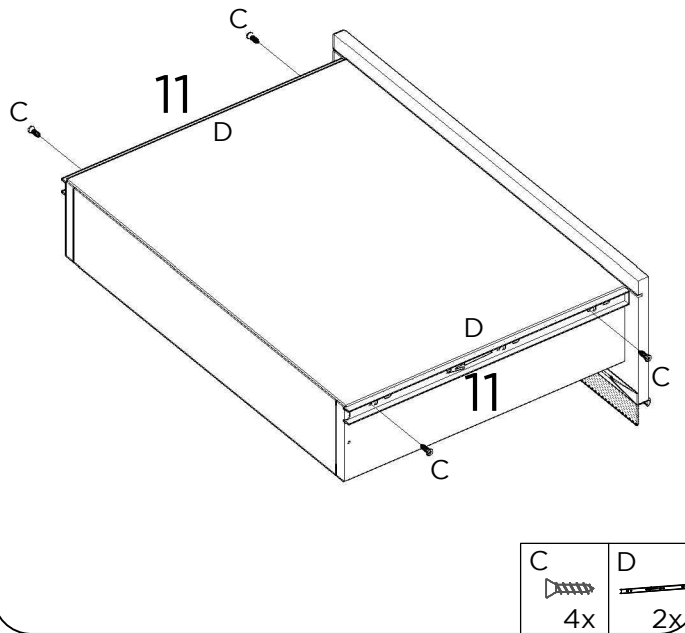
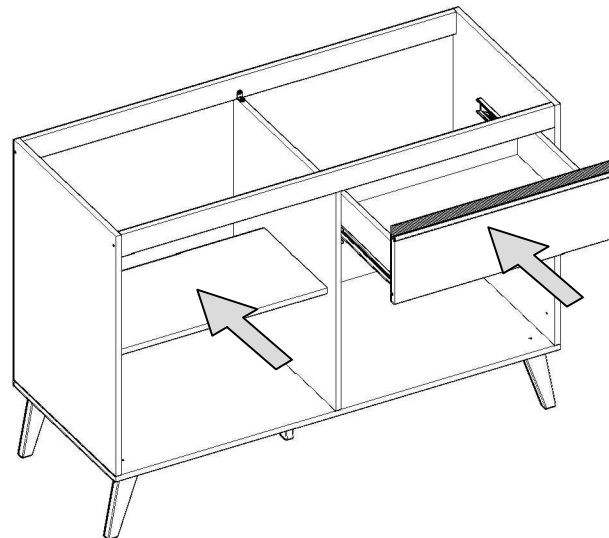
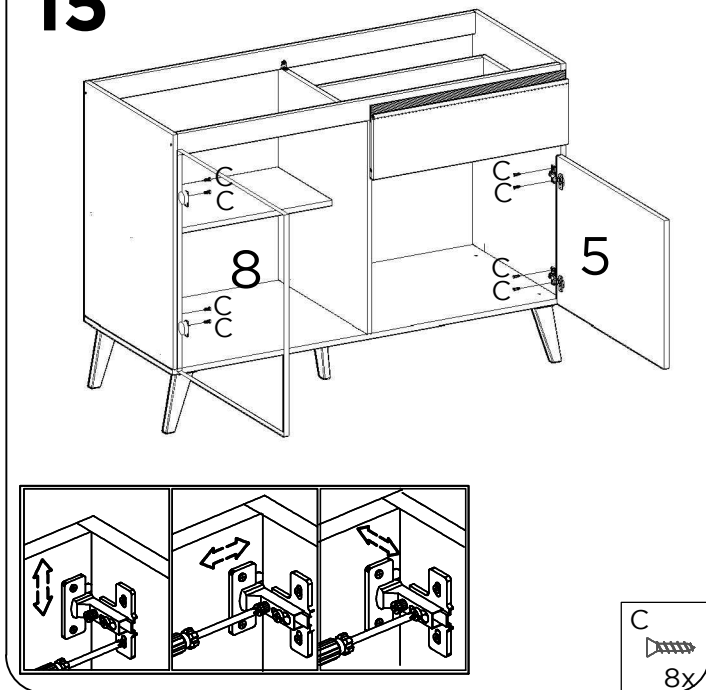
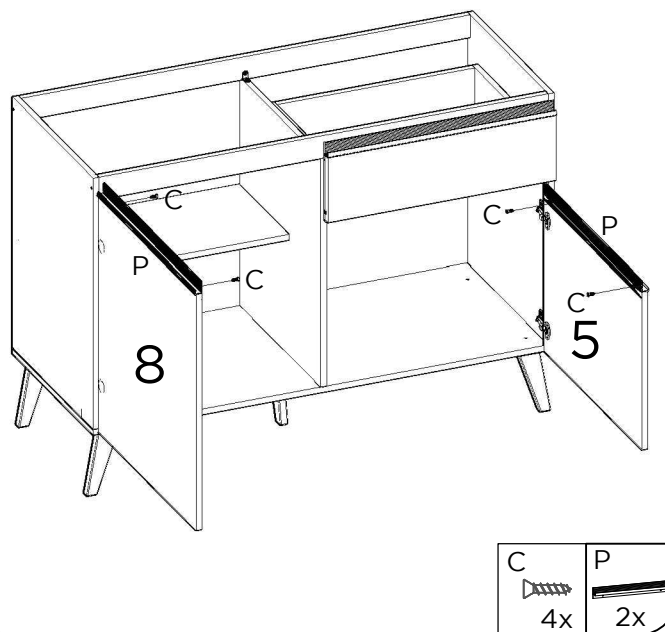
**13****14****15****16****17**

UNIR MÓDULOS  
JOINING MODULES  
UNIÓN MÓDULOS

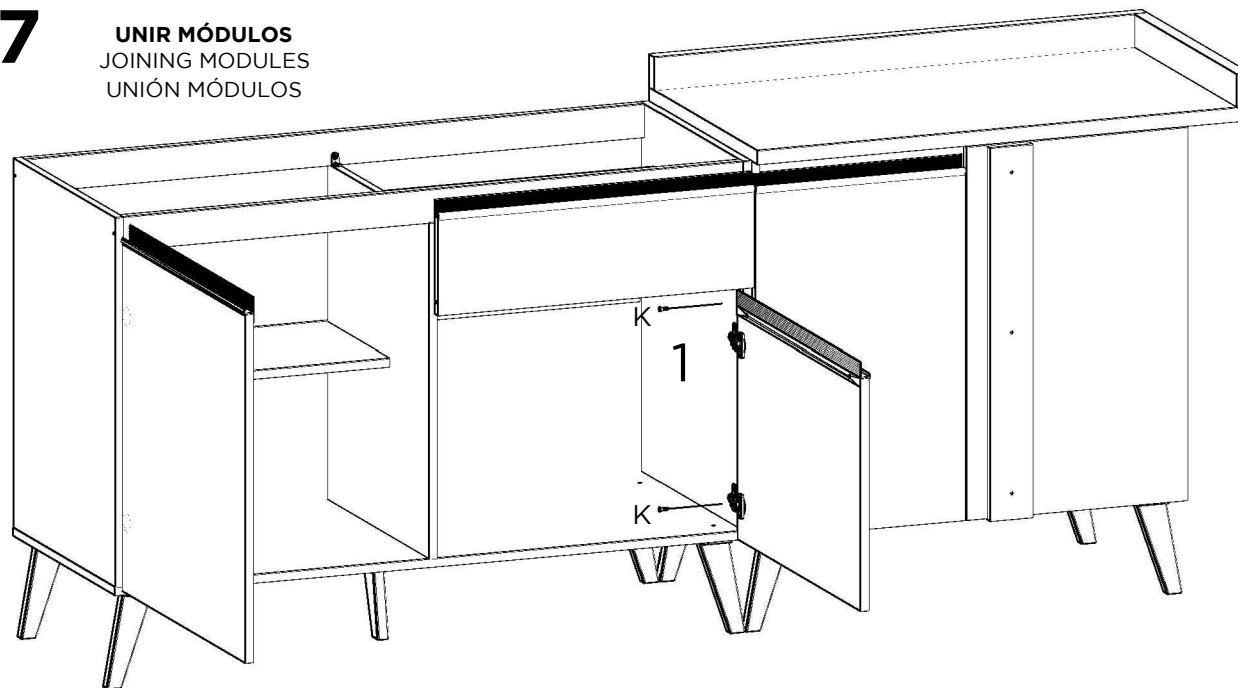

**Para instalar as corrediças telescópicas é necessário seguir os passos, separando as partes que compõem a corrediça.**

Para instalar las correderas telescópicas es necesario seguir los pasos, separando las dos partes que componen la pieza.

### Corrediça telescópica / Corredera telescópica



#### Passo 1 / Paso 1

#### Corrediça telescópica aberta / Corredera telescópica abierta

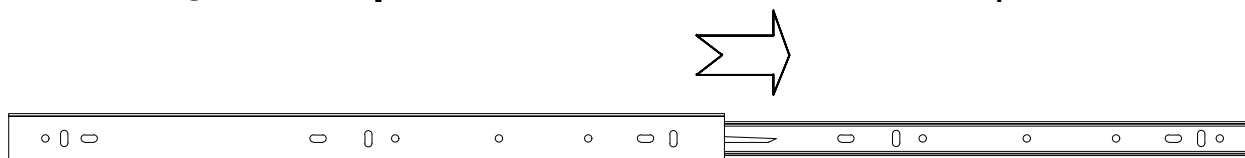

**Para separar as partes da corrediça, puxe o engate que está na parte traseira da corrediça (desenho ao lado) no sentido anti-horário, separando as duas partes, para facilitar a fixação no móvel.**

Para separar las dos partes de la corredera, tire el engate que está en la parte de atrás de la corredera (dibujo al lado) en el sentido anti-horario, separando las dos partes, para facilitar la fijación en el mueble.

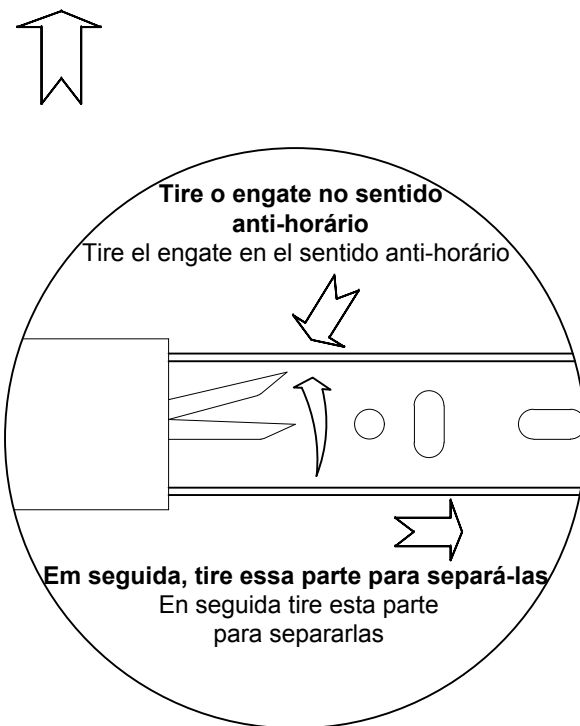

#### Passo 2 / Paso 2

**Com as partes da corrediça separadas, fixar-las no móvel.**

Con las partes de la corredera separadas, fijarlas en el mueble.

#### Parte A

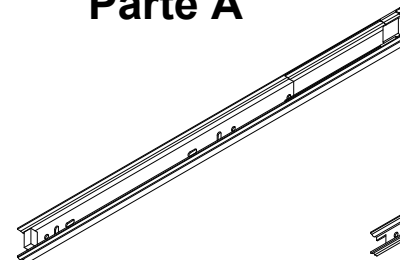

#### Parte B

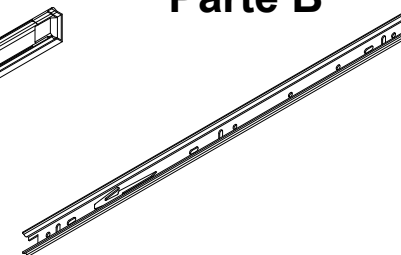

**As corrediças devem ficar alinhadas com a parte inferior das laterais de gavetas.**

Las correderas deben quedar aliñada con la parte inferior de las laterales de los cajónes.

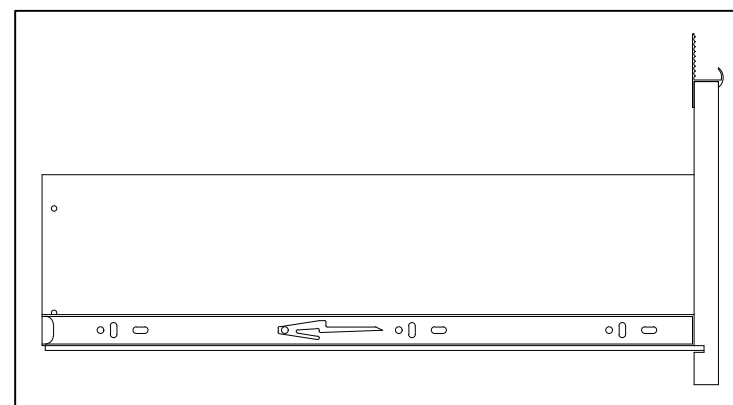

# Manual de Montagem / Plano de Armado

**Parabéns !** Você comprou um produto de excelente qualidade, fabricado com **chapa de madeira de MDP ou MDF, extraída de florestas renováveis.** Possui alta resistência e design atual.

**Felicitaciones !** Ud. compró a un producto de excelente calidad, fabricado con **placa de madera de MDP o MDF, proveniente de florestas renovables.** Tiene alta resistencia y diseño actual.

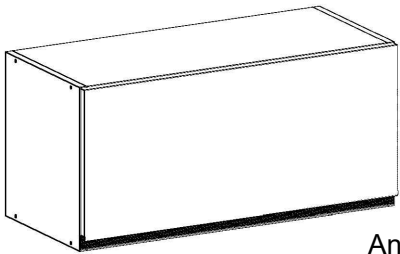

**Ref. 1203**

Antes de começar a montagem, certifique-se de que as caixas estejam em perfeitas condições.

Antes de empezar el armado asegúrese que las cajas estén en perfectas condiciones.

Antes de montar o móvel, leia com atenção o manual de montagem!  
Antes de armar el mueble, lea con atención el manual de ensamble!



Atenção:  
Atención:

- 1) Verifique todas as peças antes de começar a montagem. Verifique todas las partes antes de empezar el armado.
- 2) **Ao começar a montagem, não apoie as peças na parede. Al empezar el armado, no apoyes las partes en la pared.**
- 3) Ao colocar as peças e ferragens de lado, cuidado para não perde-las. Al poner las piezas y herrajes a parte, cuidado para no dañarlas.
- 4) O móvel deve ser montado no chão, para isso, use a própria caixa para proteger e não danificar o piso. El mueble suele ser armado al piso, para eso, use la propia caja para protegerlo y no dañar al piso.
- 5) **Comece a montagem seguindo as instruções passo a passo. Comience el armado siguiendo las instrucciones paso a paso.**
- 6) É de responsabilidade do montador seguir as instruções desse manual, **que são fundamentais para a estrutura do móvel.** Es de responsabilidad del armador seguir las instrucciones de este manual, **que son fundamentales para la estructura del mueble.**

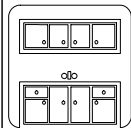

Cuidados:  
Cuidados:

- 1) A conservação e limpeza deve ser feita com um pano **levemente umedecido com água.** La conservación y limpieza debe ser hecha con un trapo **levemente humedecido en agua.**
- 2) Não use produtos abrasivos, como saponáceo, detergentes e esponja de aço. No use productos abrasivos, como saponáceo, detergentes y esponja de acero.
- 3) **Não use cera ou óleo para dar brilho ao móvel. No use cera o aceites para darle brillo al mueble.**
- 4) Não expor o móvel a intempéries e nem ao calor excessivo. No exponer el mueble a intemperies ni al calor excesivo .
- 5) **Ao terminar a montagem, limpe o ambiente e o móvel. A terminar el armado, limpie al ambiente y al mueble.**

Ferramentas:  
Herramientas:



Ítem	Descrição / Descripción	Qtd.
1	Lateral / Lateral	2
3	Tampo / Tope	1
5	Costa / Tasero	1
9	Porta / Puerta	1
12	Base / Base	1

ITEM	LISTA DE FERRAGENS	DESCRIÇÃO	QTD.
ITEM	LISTA DE HERRAJES	DESCRIPCIÓN	QTD.
C1		CAVILHAS 8X30 CLAVIJAS 8X30	8
P1		PARAFUSO 4X50 TORNILLO 4X50	8
P2		PARAFUSO 4X14 TORNILLO 4X14	15
R1		PREGO 10X10 CLAVO 10X10	16
P4		PARAFUSO 3,5X25 TORNILLO 3,5X25	2
D1		CALÇO DE DOBRADIÇA 26MM CALZO DE BISAGRA 26MM	2
D2		DOBRADIÇA 26mm BISAGRA 26mm	2
U1		PUXADOR TIRADOR	1
P5		PARAFUSO 5X50 TORNILLO 5X50	2
PT		PISTÃO PISTÓN	1
S3		SUPORTE DE FIXAÇÃO SOPORTE FIJACIÓN	2
CP		CAPA PARA SUPORTE CUBIERTA PARA SOPORTE	2
BA		BUCHA BUSH	2

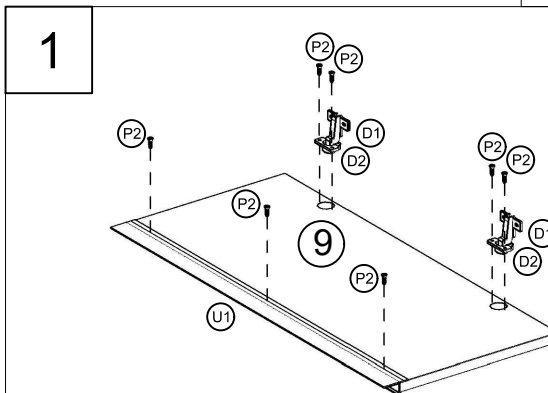
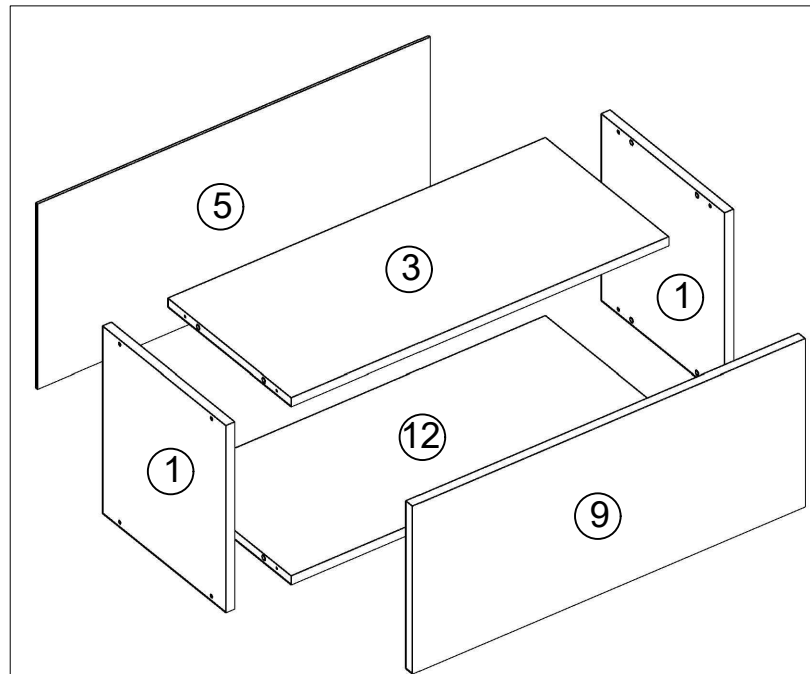

**Fijación da peça "D2" na peça "D1", para na sequência fixar o conjunto da dobradiça na porta.**

Fijación de la pieza "D2" en la pieza "D1", para después fijar el conjunto de la bisagra en la puerta.

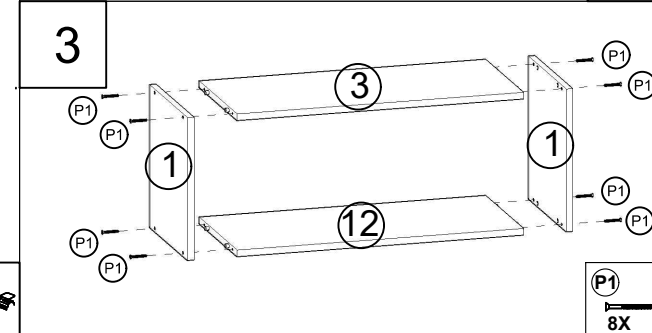
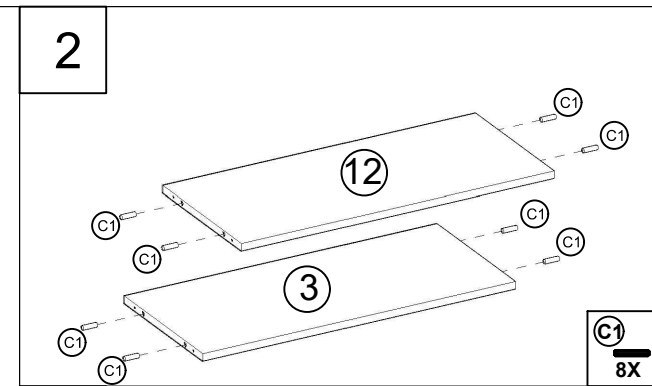
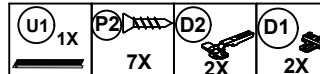
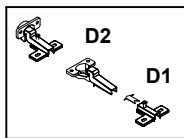

4

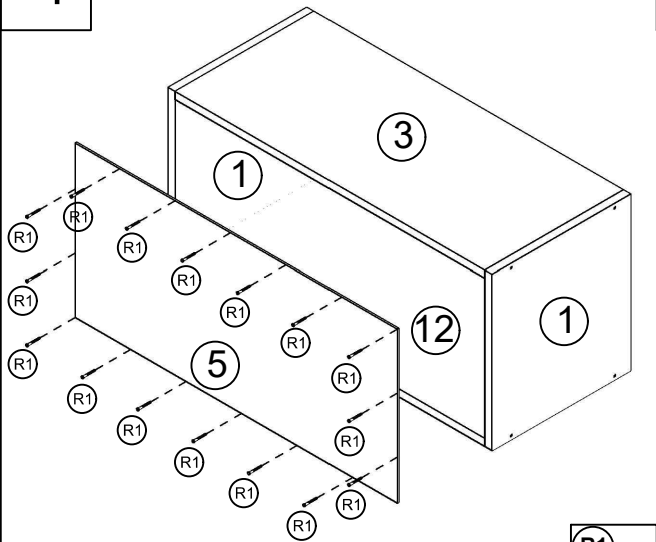

R1 16X

5

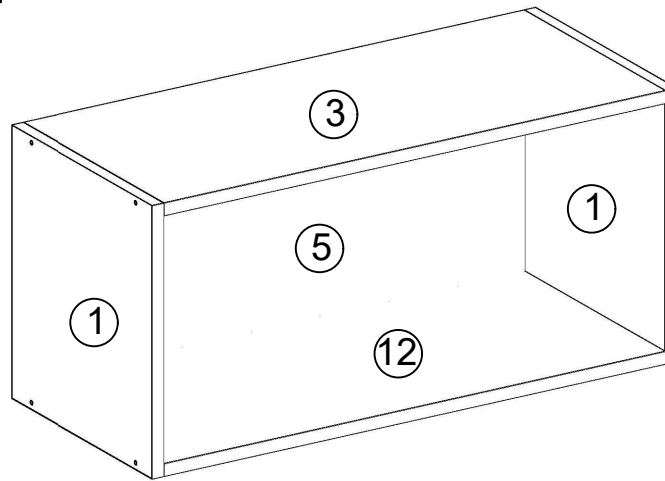

Realizar a fixação do móvel na parede através dos suportes de fixação (S3), bucha alvenaria (BA) e dos parafusos alvenaria (P5), devendo ser realizada nas laterais do móvel.

Realizar la fijación del mueble en la pared a través de los soportes de fijación (S3), bush (BA) y tornillos (P5). Se debe realizar en los lados del mueble.

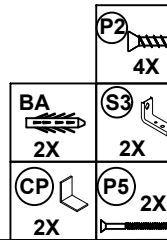
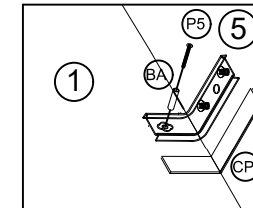
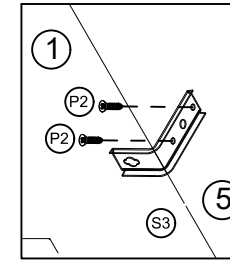

6

REGULAGEM DAS PORTAS  
AJUSTE DE LAS PUERTAS

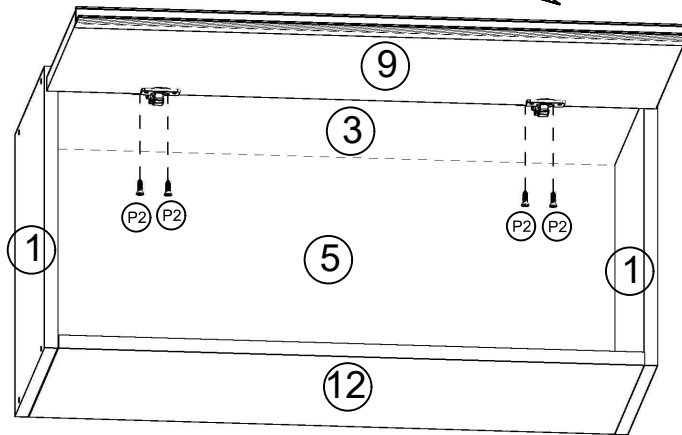
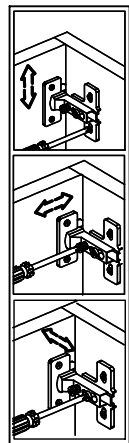

Fixação do pistão  
Fijación del pistón

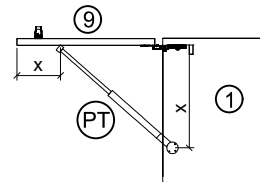

A fixação do pistão deve ser realizada de acordo com o manual que ocorre na embalagem deste acessório, devendo ser realizada na porta basculante (9).

La fijación del pistón debe ser hecha de acuerdo con el manual que viene dentro de la embalagem del accesorio, debiendo ser hecha en la puerta basculante (9).

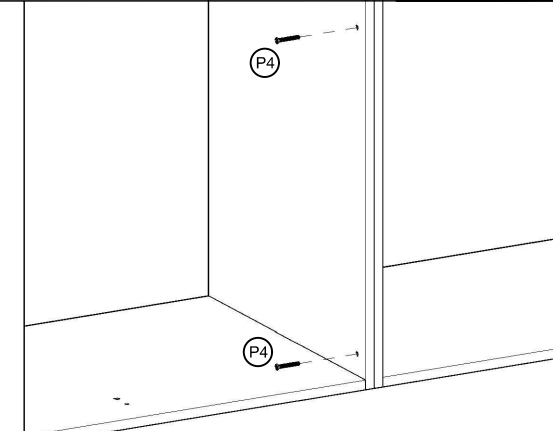

Para realizar a união entre diferentes módulos, fazer uso do parafuso "P4".

Para hacer la unión entre los diferentes módulos, utilice los tornillos "P4".

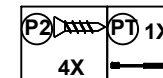

# MANUAL DE MONTAGEM / ASSEMBLY INSTRUCTIONS / PLANO DE ARMADO

**Antes de montar o móvel, leia com atenção o manual de montagem!**  
**Before assembling the furniture, carefully read the assembly instructions!**  
**Antes de armar el mueble, lea con atención el manual de ensamble!**

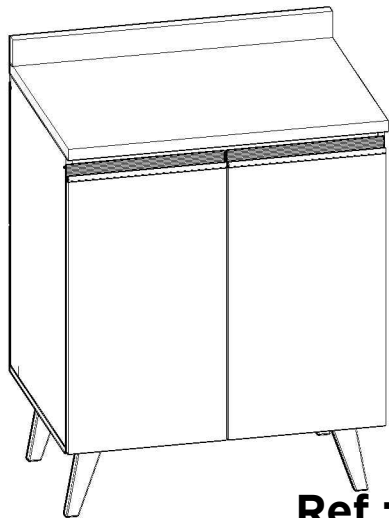

**Ref.: 1253**

**genialflex**  
ambientes incríveis para todos

Parabéns! Você comprou um produto de excelente qualidade, fabricado com chapa de madeira de MDP ou MDF, extraída de florestas renováveis. Possui alta resistência e design atual.

Congratulations! You have purchased a product of excellent quality, made from MDP or MDF wood veneer, extracted from renewable forests. It has high strength and current design.

Felicitaciones! Usted compró a un producto de excelente calidad, fabricado con placa de madera de MDP o MDF, proveniente de florestas renovables. Tiene alta resistencia y diseño actual.



**ATENÇÃO**  
**ATTENTION**  
**ATENCIÓN**

- 1)** Verifique todas as peças antes de começar a montagem.  
Check all parts before starting assembly.  
Verifique todas las partes antes de empezar el armado.
- 2)** Ao começar a montagem, não apoie as peças na parede.  
When starting the assembly, do not support the parts on the wall.  
Al empezar el armado, no apoyes las partes en la pared.
- 3)** Ao colocar as peças e ferragens de lado, cuidado para não perde-las.  
When placing parts and hardware aside, be careful not to lose them.  
Al poner las piezas y herrages a parte, cuidado para no dañarlas.
- 4)** O móvel deve ser montado no chão, para isso, use a própria caixa para proteger e não danificar o piso.  
The furniture must be mounted on the floor, to do this, use the box itself to protect and not damage the floor.  
El mueble suele ser armado al piso, para eso, use la propia caja para protegerlo y no dañar al piso.

- 5)** Comece a montagem seguindo as instruções passo a passo.  
Begin assembly by following the step-by-step instructions.  
Comience el armado siguiendo la instrucciones paso a paso.
- 6)** É de responsabilidade do montador seguir as intruções desse manual, que são fundamentais para a estrutura do móvel.  
It's the assembler's responsibility to follow the instructions in this manual, which are fundamental to the structure of the furniture.  
Es de responsabilidad del armador seguir las instrucciones de este manual, que son fundamentales para la estructura del mueble.

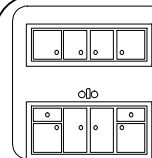

**CUIDADOS**  
**CARE**  
**CUIDADO**

- 1)** A conservação e limpeza deve ser feita com um pano levemente umedecido com água.  
Care and cleaning should be done with a cloth slightly moistened with water.  
La conservación y limpieza debe ser hecha con un trapo levemente humedecido en agua.
- 2)** Não use produtos abrasivos, como saponáceo, detergentes e esponja de aço.  
Do not use abrasive products, such as soap, detergents and steel sponge.  
No use productos abrasivos, como saponáceo, detergentes y esponja de acero.
- 3)** Não use cera ou óleo para dar brilho ao móvel.  
Do not use wax or oil to shine the furniture.  
No use cera o aceites para darle brillo al mueble.
- 4)** Não expor o móvel a interpéries e nem ao calor excessivo.  
Do not expose the furniture to weather or excessive heat.  
No exponer el mueble a interperies ni al calor excesivo.
- 5)** Ao terminar a montagem, limpe o ambiente e o móvel.  
When the assembly is finished, clean the room and the furniture.  
Al terminar el armado, limpie al ambiente y al mueble.

## FERRAMENTAS / TOOLS / HERRAMIENTAS



MARTELO  
HAMMER  
MARTILLO



MARTELO DE BORRACHA  
RUBBER HAMMER  
MARTILLO GOMA



CHAVE PHILLIPS  
PHILLIPS SCREWDRIVER  
LLAVE PHILLIPS









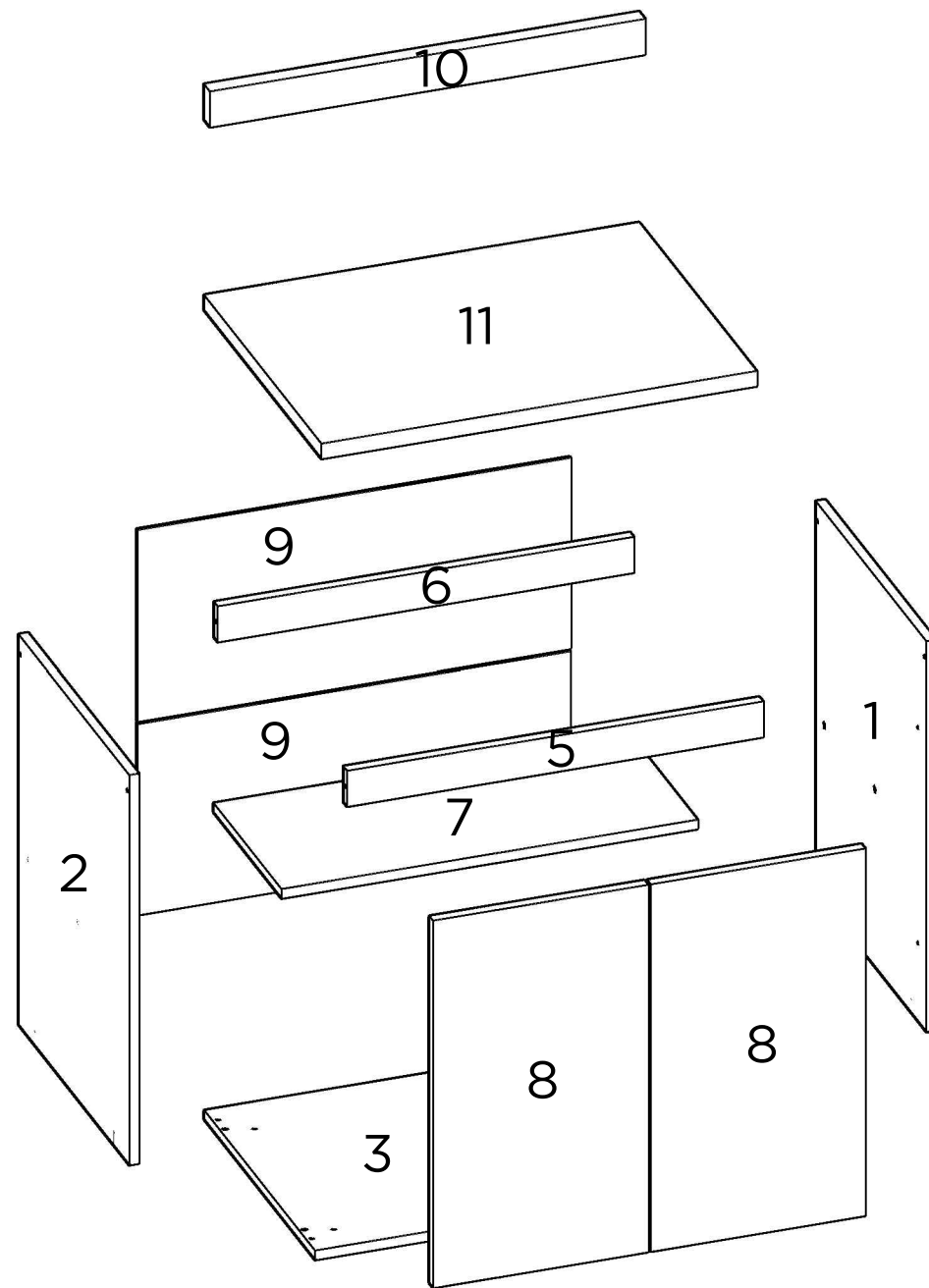



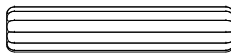

TRENA  
MEASURING TAPE  
CINTA MÉTRICA

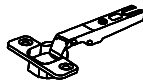
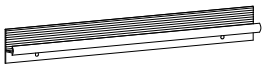
**PEÇAS / PARTS / PIEZAS**

Nº No Num	DESCRIÇÃO DESCRIPTION DESCRIPCIÓN	QTD QTY CANT
1	LATERAL DIREITA RIGHT SIDE PANEL LATERAL DERECHA	1
2	LATERAL ESQUERDA LEFT SIDE PANEL LATERAL IZQUIERDA	1
3	BASE BOTTOM BASE	1
5	TRAVESSA FRONTAL FRONTAL PLATE TRAVESAÑO FRONTAL	1
6	TRAVESSA TRASEIRA BACK PLATE TRAVESAÑO TRASERO	1
7	PRATELEIRA PLATE PANEL REPISA	1
8	PORTA DOOR PUERTA	2
9	COSTA BACK PANEL TRASERO	2
10	ESPELHO MIRROR PANEL ESPEJO	1
11	TAMPO TOP TABLERO	1

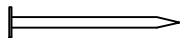
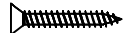

## FERRAGENS / HARDWARE / HERRAJES

CÓD CODE COD	DESCRIÇÃO DESCRIPTION DESCRIPCIÓN	QTD QTY CANT
A	 CAVILHA WOODEN DOWEL TARUGO	4
B	 SUPORTE DE PRATELEIRA SHELF SUPPORT SOPORTE DE ESTANTES	4
C	 PARAFUSO 4X14mm SCREW 4X14mm TORNILLO 4X14mm	16
D	 CANTONEIRA DE 2 FUROS METALLIC ANGLE CANTONERA 2 AGUJEROS	4
E	 CALÇO PARA DOBRADIÇA HINGE SHED CALZO DE BISAGRA	4
F	 DOBRADIÇA HINGE BIZAGRA	4
G	 PUXADOR PULLER TIRADOR	2
H	 PARAFUSO 4X60mm SCREW 4X60mm TORNILLO 4X60mm	3
I	 PÉ LEG PATA	4
J	 TAPA-FURO HOLE COVER TAPA AGUJERO	4
K	 PARAFUSO 3,5X40mm SCREW 3,5X40mm TORNILLO 3,5X40mm	8
L	 PERFIL I PROFILE I PERFIL I	1
M	 PREGO NAIL CLAVO	28
N	 PARAFUSO 3.5X25mm SCREW 3.5X25mm TORNILLO 3.5X25mm	3
O	 PARAFUSO 4X16mm SCREW 4X16mm TORNILLO 4X16mm	16

UTILIZE A RÉGUA PARA IDENTIFICAR OS PARAFUSOS  
USE THE RULER TO IDENTIFY THE SCREWS  
UTILICE LA REGLA PARA IDENTIFICAR LOS TORNILLOS



**PESO SUPORTADO / WEIGHT SUPPORTED / PESO SOPORTADO**

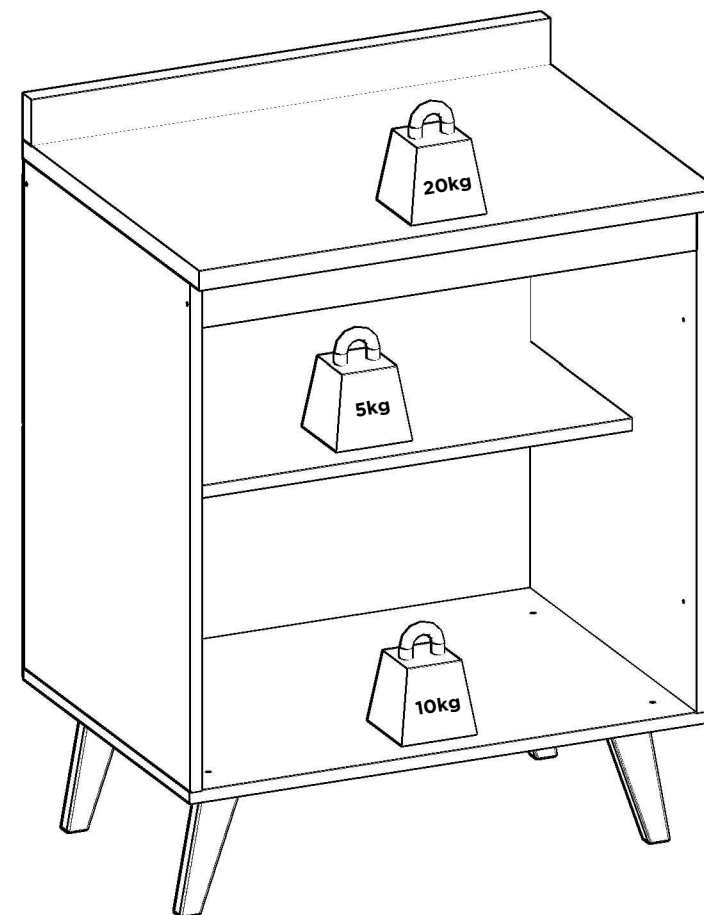

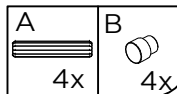
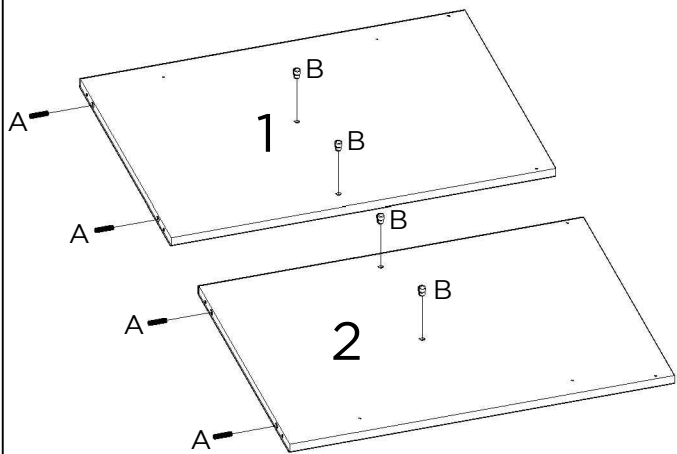
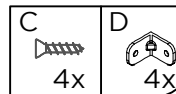
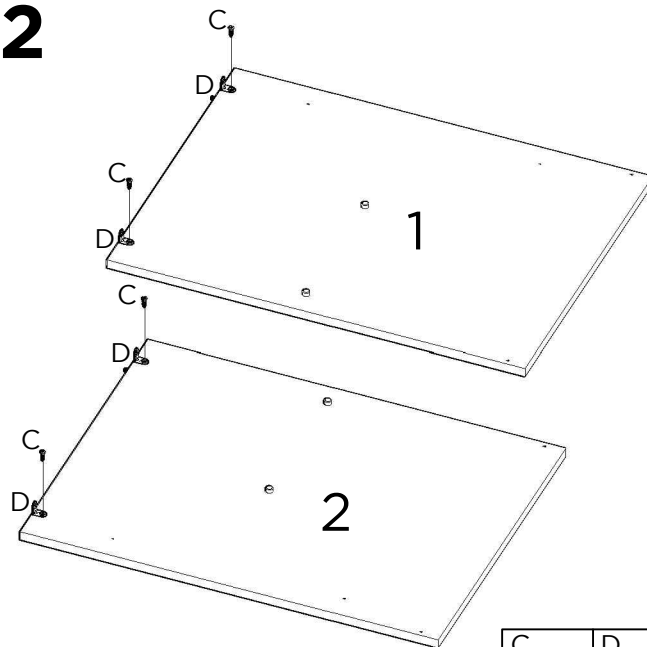
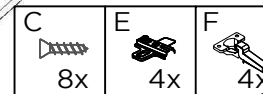
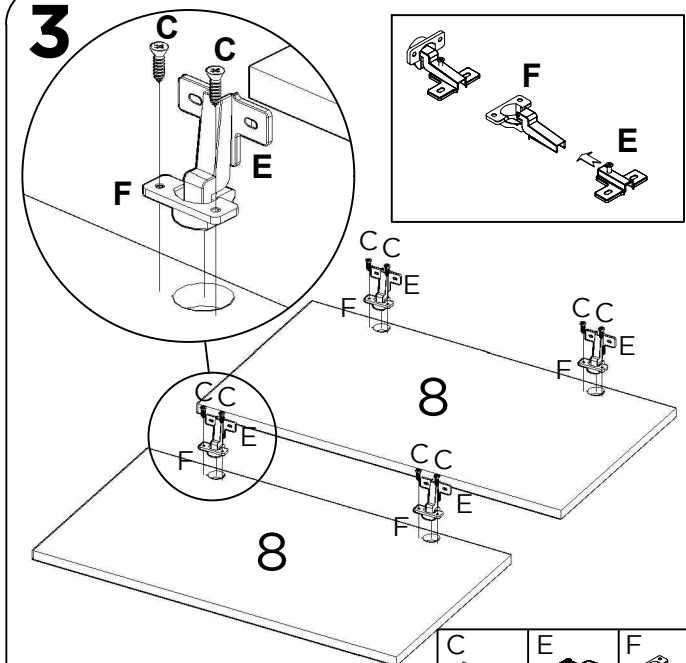
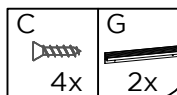
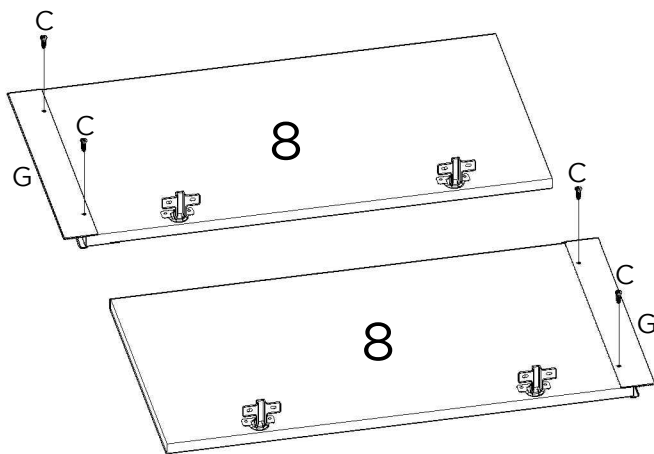
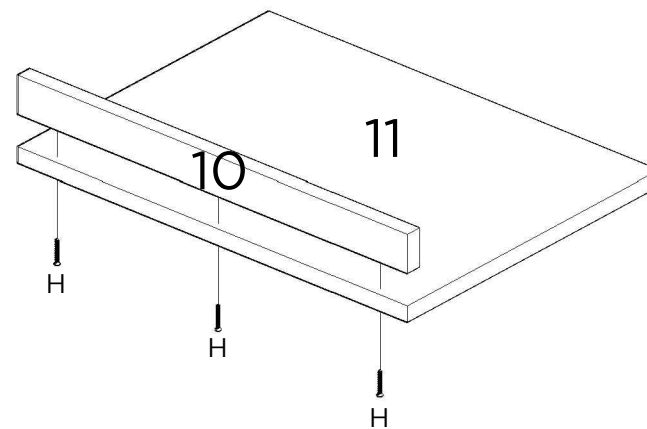
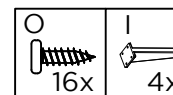
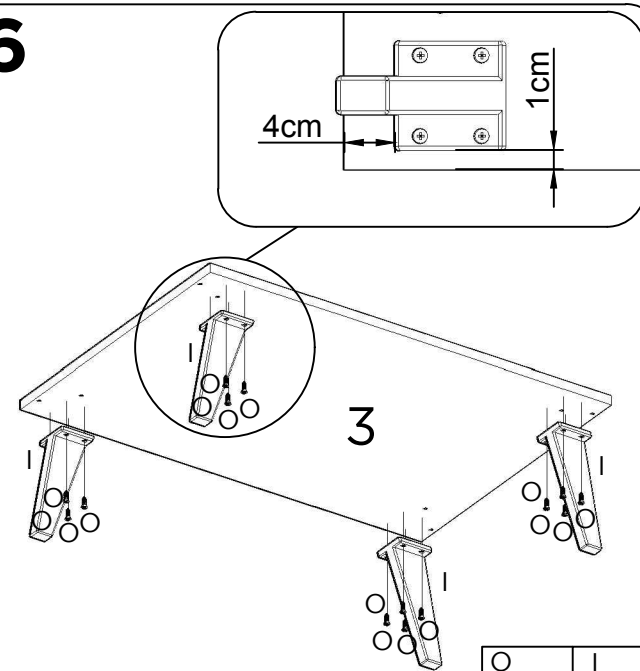
**1****2****3****4****5****6**

7

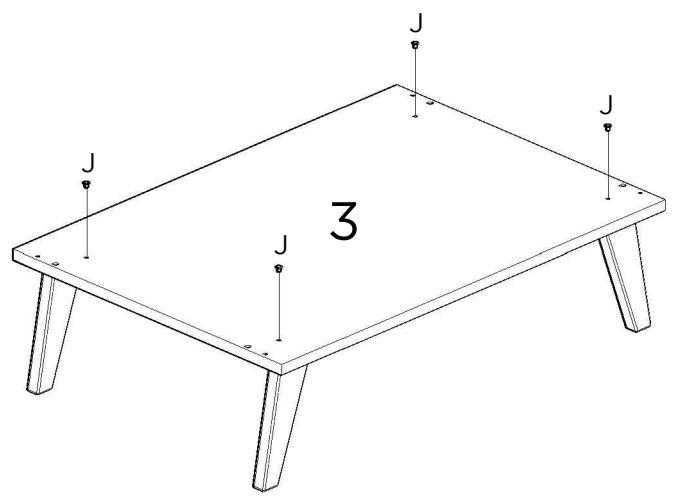

J  
4x

8

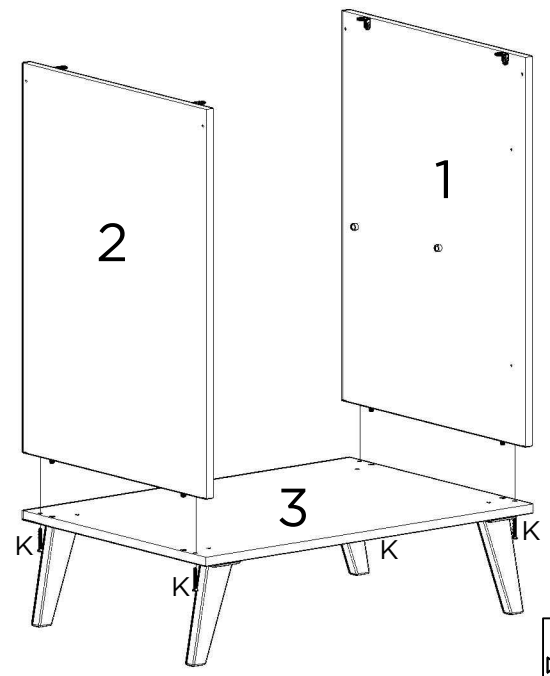

K  
4x

9

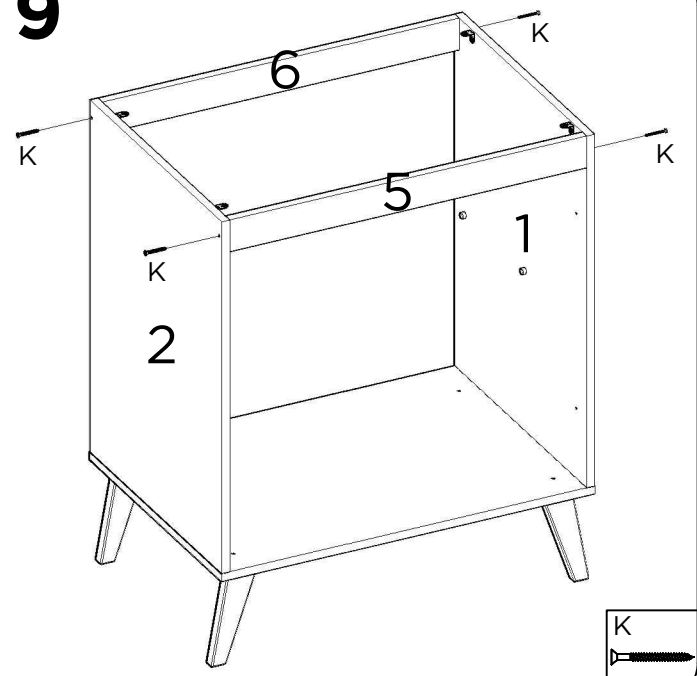

K  
4x

10

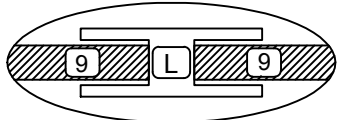
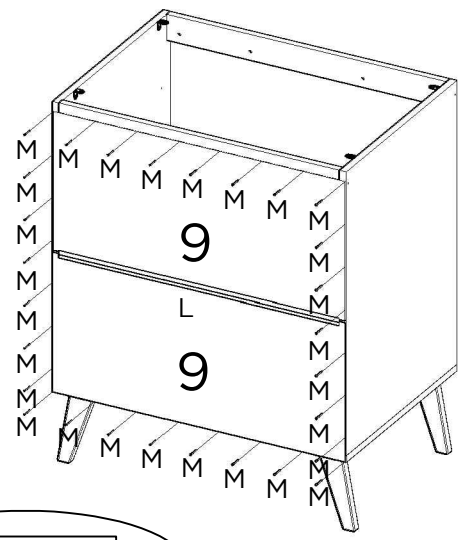

L  
1x

M  
28x

11



12

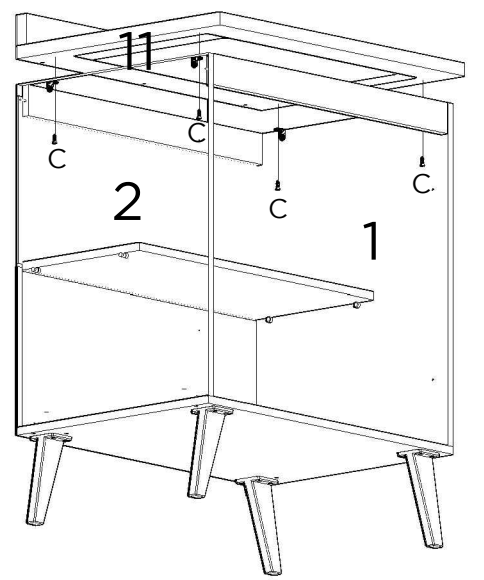

C  
4x

13

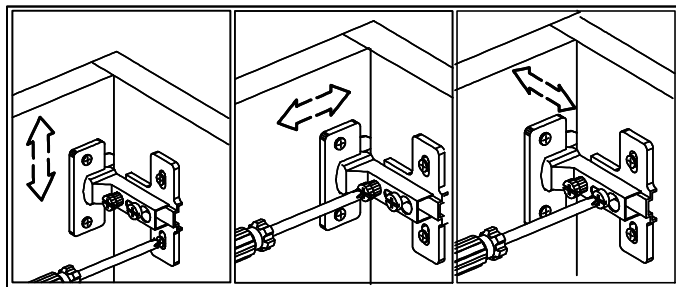
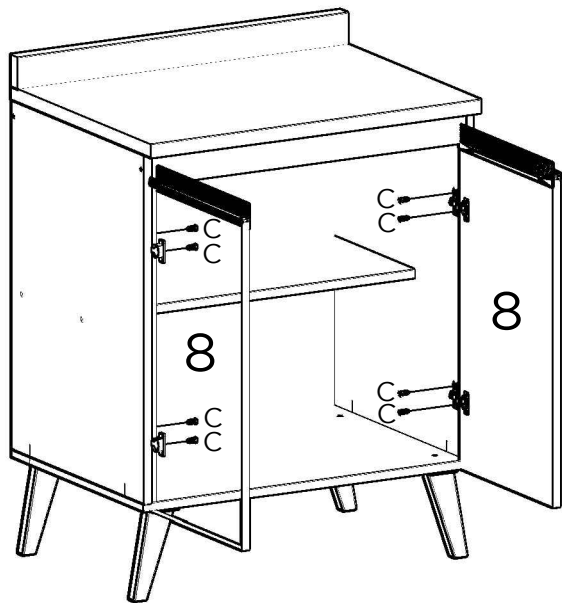

C  
8x

14

UNIÃO DE MÓDULOS  
JOINING MODULES  
UNIÓN DE MÓDULOS

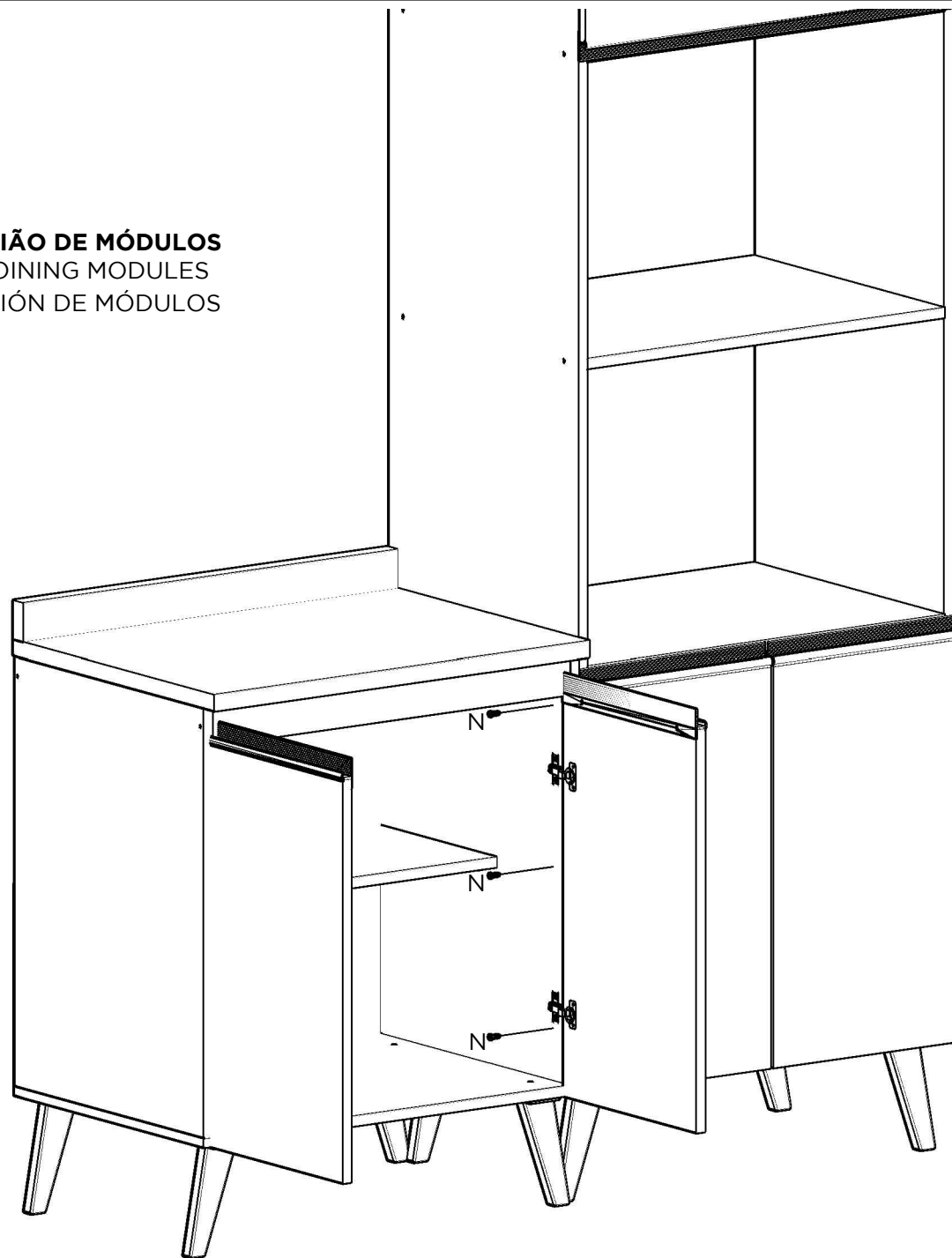

N  
3x

# MANUAL DE MONTAGEM / PLANO DE ARMADO

**Parabéns! Você comprou um produto de excelente qualidade, fabricado com chapa de madeira de MDP ou MDF, extraída de florestas renováveis. Possui alta resistência e design atual.**

Felicitaciones! Usted compró a un producto de excelente calidad, fabricado con placa de madera de MDP o MDF, proveniente de florestas renovables. Tiene alta resistencia y diseño actual.

**Antes de montar o móvel, leia com atenção o manual de montagem!**  
**Antes de armar el mueble, lea con atención el manual de ensamble!**



**ATENÇÃO:**  
**ATENCIÓN:**

- 1) Verifique todas as peças antes de começar a montagem.**  
Verifique todas las partes antes de empezar el armado.
- 2) Ao começar a montagem, não apoie as peças na parede.**  
Al empezar el armado, no apoyes las partes en la pared.
- 3) Ao colocar as peças e ferragens de lado, cuidado para não perde-las.**  
Al poner las piezas y herrages a parte, cuidado para no dañarlas.
- 4) O móvel deve ser montado no chão, para isso, use a própria caixa para proteger e não danificar o piso.**  
El mueble suele ser armado al piso, para eso, use la propia caja para protegerlo y no dañar al piso.
- 5) Comece a montagem seguindo as instruções passo a passo.**  
Comience el armado siguiendo la instrucciones paso a paso.
- 6) É de responsabilidade do montador seguir as intruções desse manual, que são fundamentais para a estrutura do móvel.**  
Es de responsabilidad del armador seguir las instrucciones de este manual, que son fundamentales para la estructura del mueble.

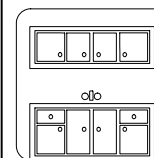

- 1) A conservação e limpeza deve ser feita com um pano levemente umedecido com água.**  
La conservación y limpieza debe ser hecha con un trapo levemente humedecido en agua.
- 2) Não use produtos abrasivos, como saponáceo, detergentes e esponja de aço.**  
No use productos abrasivos, como saponáceo, detergentes y esponja de acero.

**CUIDADOS:**

**CUIDADOS:**

- 3) Não use cera ou óleo para dar brilho ao móvel.**  
No use cera o aceites para darle brillo al mueble.
- 4) Não expor o móvel a interperies e nem ao calor excessivo.**  
No exponer el mueble a interperies ni al calor excesivo.
- 5) Ao terminar a montagem, limpe o ambiente e o móvel.**  
Al terminar el armado, limpie al ambiente y al mueble.

**FERRAMENTAS:**  
**HERRAMIENTAS:**



**Martelo de borracha**  
Martillo Goma



**Martelo**  
Martillo



**Chave Phillips**  
Llave Phillips



**Trena**  
Cinta métrica

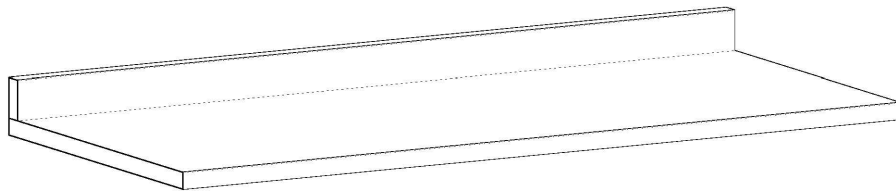

**Ref.: 0298**

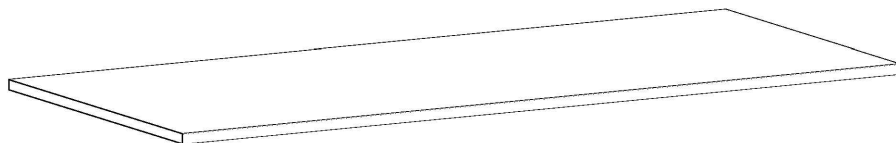

**Ref.: 0299**

**Antes de começar a montagem certifique-se que as caixas estão em perfeitas condições.**

Antes de empezar el armado asegúrese que las cajas estén en perfectas condiciones.



**genialflex**  
ambientes incríveis para todos

**Ref.: 0298**

LISTA DE PEÇAS / LISTA DE PIEZAS

Nº	Descrição / Descripción	Qtd. Cant.
1	Tampo / Tablero	1
2	Espelho / Espejo	1

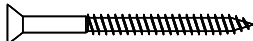
LISTA DE FERRAGENS / LISTA DE HERRAJES

ITEM ITEM	DESCRIÇÃO / DESCRIPCIÓN	QTD. CANT.
<b>P1</b>	 <b>PARAFUSO 3,5X14</b> TORNILLO 3,5X14	<b>16</b>
<b>P16</b>	 <b>PARAFUSO 4X60</b> TORNILLO 4X60	<b>4</b>
<b>S1</b>	 <b>CHAPA "L" 2 FUROS</b> PLACA "L" 2 AGUJEROS	<b>8</b>

USE A RÉGUA PARA IDENTIFICAR OS PARAFUSOS  
UTILICE LA REGLA PARA IDENTIFICAR LOS TORNILLOS

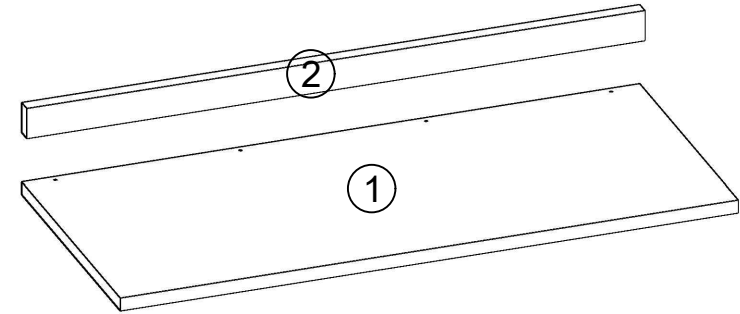
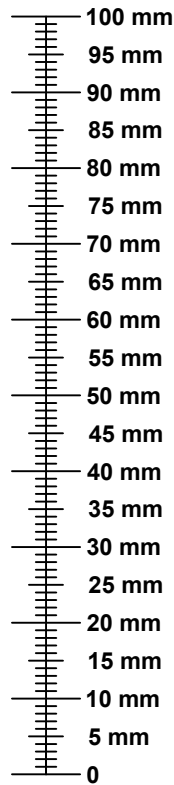

**1**

**FIXE O ESPELHO (2) NO TAMPO (1)**  
**FIJE EL ESPEJO (2) EN EL TABLERO (1)**

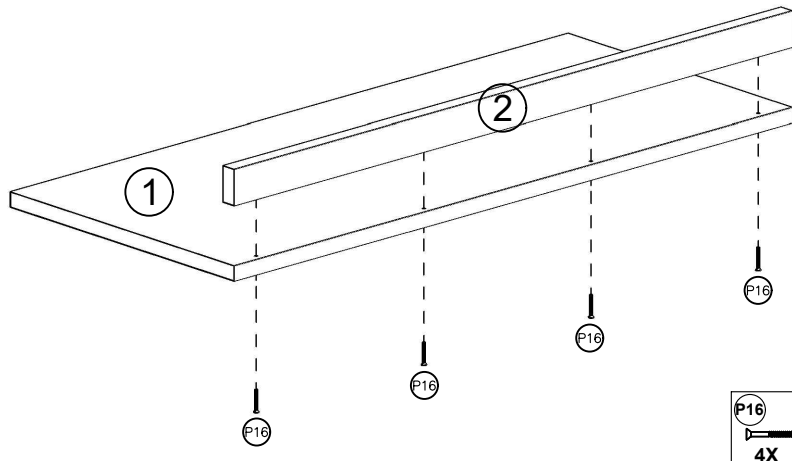

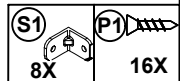
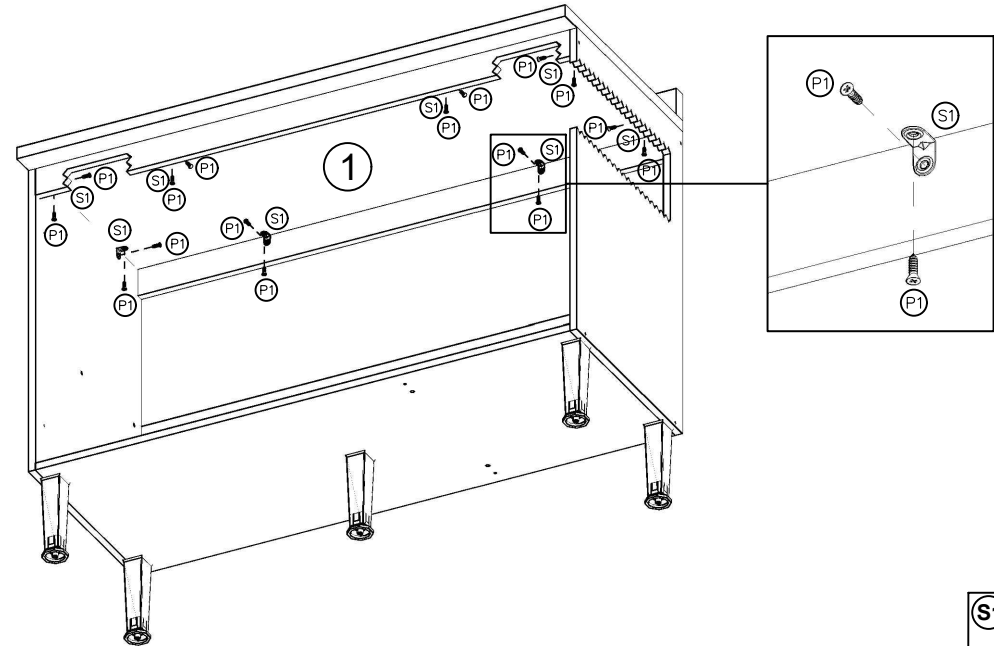

**2**

**FIXE O TAMPO (1) NO BALCÃO**  
**FIJE EL TABLERO (1) EN EL MUEBLE BAJO**



**Ref.: 0299**

LISTA DE PEÇAS / LISTA DE PIEZAS		
Nº	Descrição / Descripción	Qtd. Cant.
1	Tampo / Tablero	1

LISTA DE FERRAGENS / LISTA DE HERRAJES		
ITEM ITEM	DESCRIÇÃO / DESCRIPCIÓN	QTD. CANT.
<b>P1</b>	 <b>PARAFUSO 3,5X14</b> TORNILLO 3,5X14	<b>16</b>
<b>S1</b>	 <b>CHAPA "L" 2 FUROS</b> PLACA "L" 2 AGUJEROS	<b>8</b>

USE A RÉGUA PARA IDENTIFICAR OS PARAFUSOS  
UTILICE LA REGLA PARA IDENTIFICAR LOS TORNILLOS

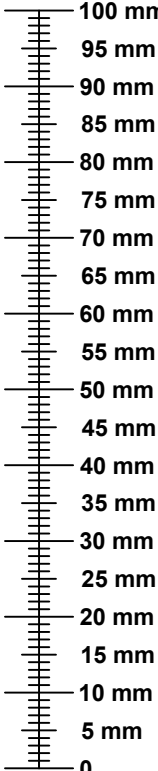
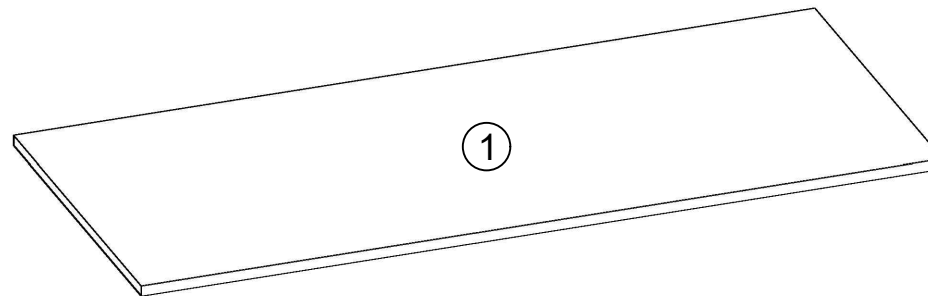
**1**

**FIXE O TAMPO (1) NO BALCÃO**  
**FIJE EL TABLERO (1) EN EL**  
**MUEBLE BAJO**

