

CO5006 - COZINHA

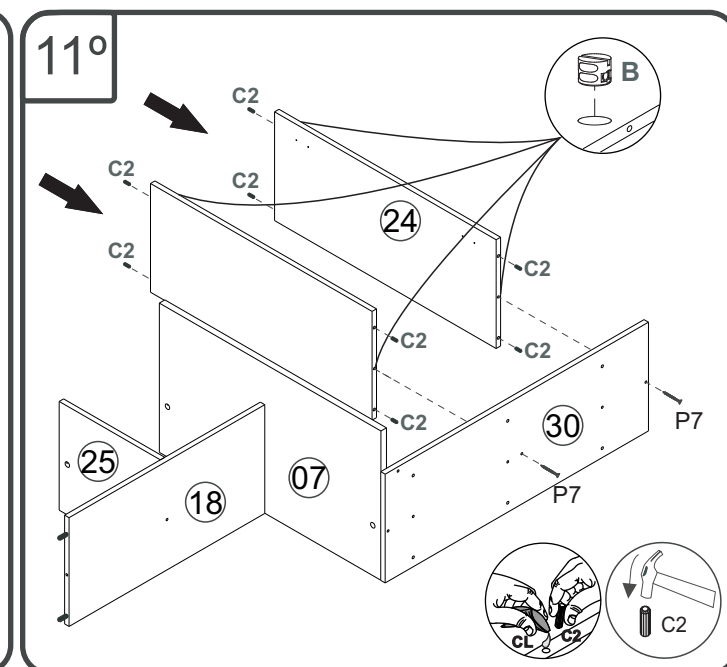
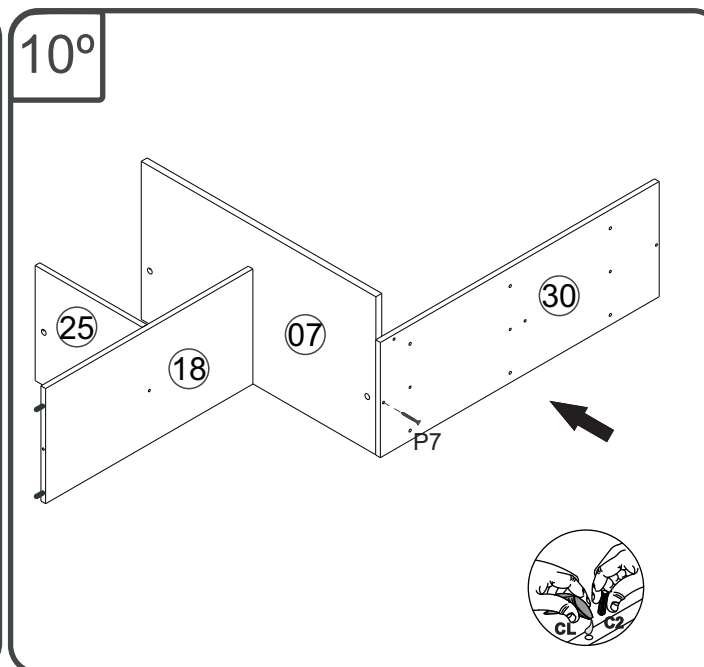
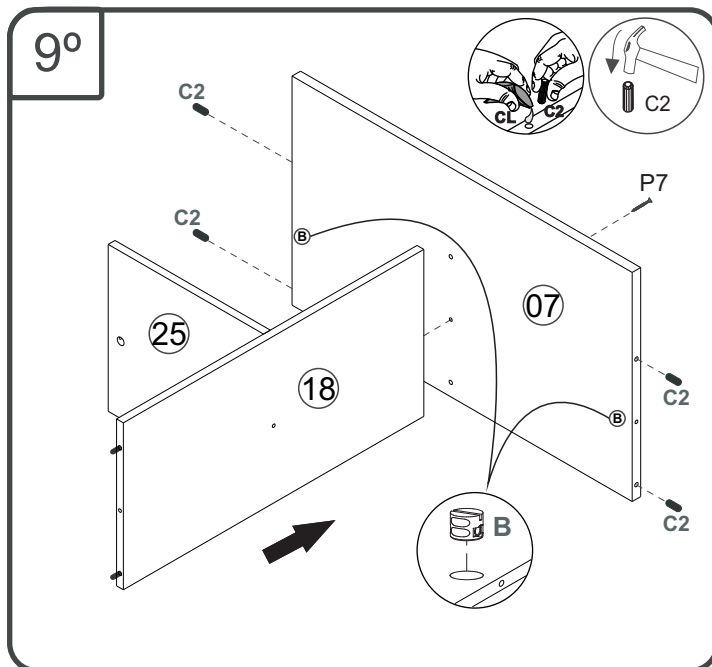
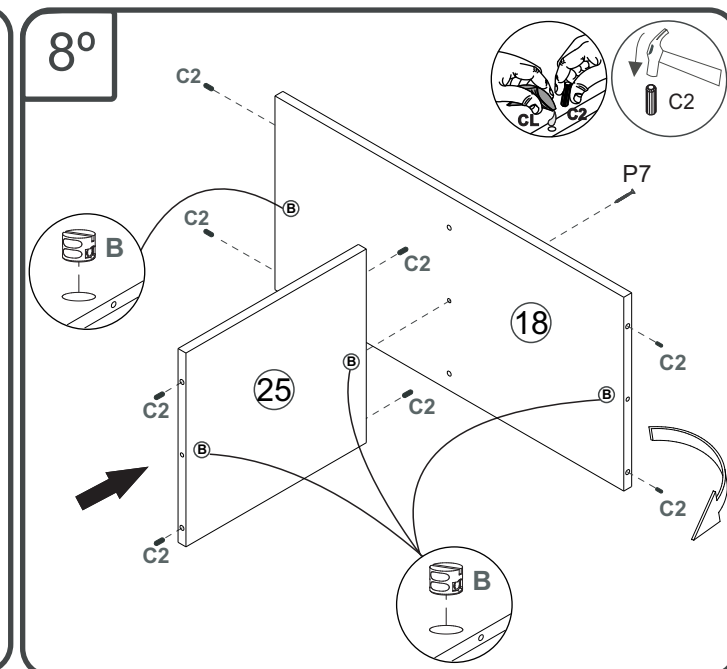
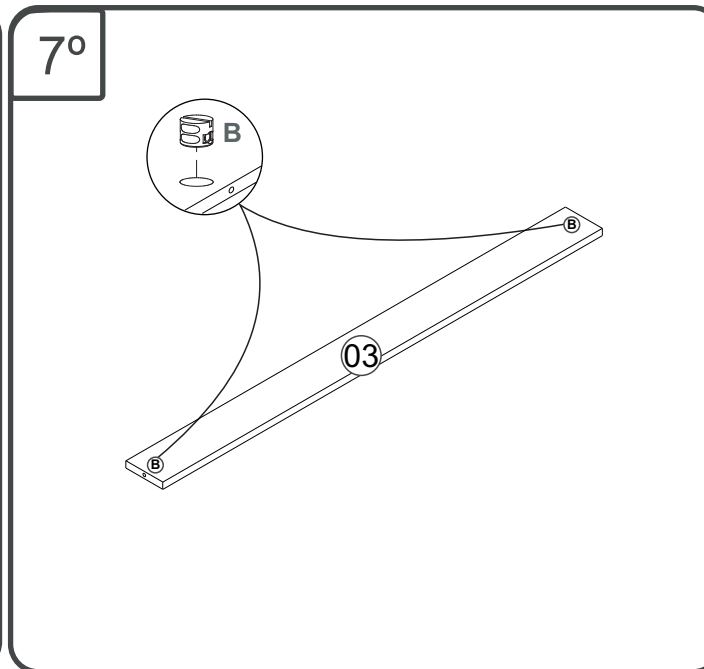
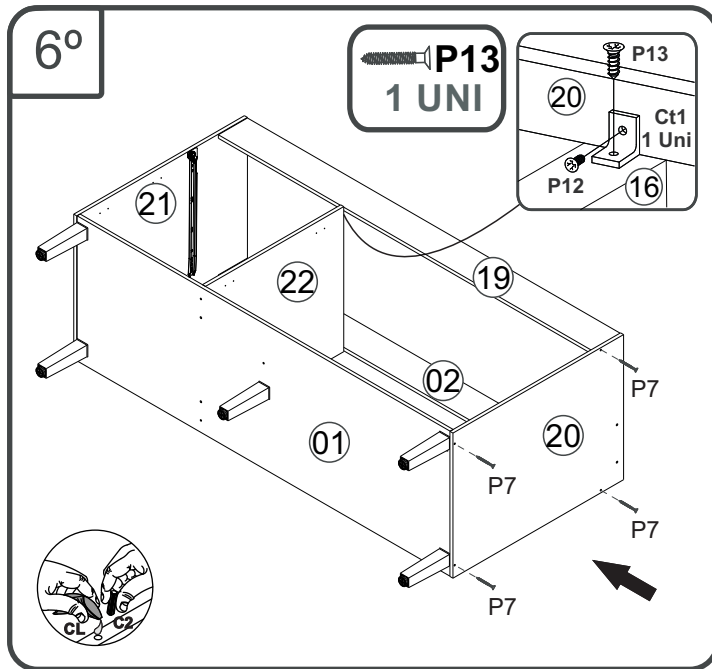

CO5006 - COZINHA

12°

Diagram 12 shows the assembly of panel 29 to panel 31. Panel 29 is being moved towards panel 31. Screws P6 are used to secure the connection. Part B is also shown.

P6
1 UNI

13°

Diagram 13 shows the assembly of panel 17 to the assembly. Panel 17 is being moved towards the assembly. Screws P7 are used to secure the connection. Part B is also shown.

14°

Diagram 14 shows the assembly of panel 05 to the cabinet frame. Panel 05 is being moved towards the frame. Screws Pr1 and Pr2 are used to secure the connection. Part P12 is also shown.

ATENÇÃO!!!!
 MARCAÇÃO PRA O PRIMEIRO FURO DO PUXADOR
 MARCADO PARA EL PRIMER AGUJERO
 MARKING FOR THE FIRST HANDLE HOLE

Diagram 15 shows the marking of the first handle hole on panel 05. A hand is shown marking a hole on panel 05 with a pencil. The distance from the edge is 18,2CM. Part Px1 is also shown.

Diagram 16 shows the assembly of panel 13 to the cabinet frame. Panel 13 is being moved towards the frame. Screws P1 and CR are used to secure the connection.

CO5006 - COZINHA

Manual de Montagem
Assembly Instructions
Instrucción de Montaje

decibal[®]
móveis

15°

P7
2 UNI

P6
1 UNI

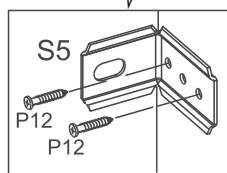
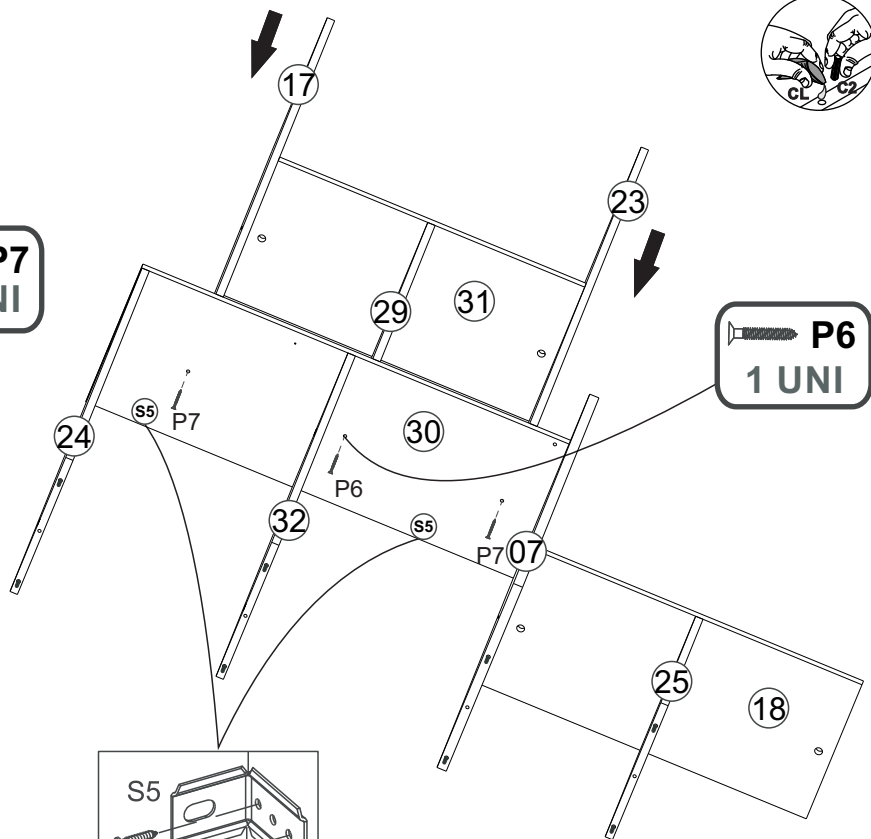

Atenção!

Produto exige fixação a parede conforme o indicado no manual para evitar danos ao mesmo.

¡Atención!

El producto requiere fijación a la pared como se indica en el manual para evitar dañarlo.

Attention!

Product requires wall fixing as indicated in the manual to avoid damage to it.

16°

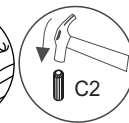
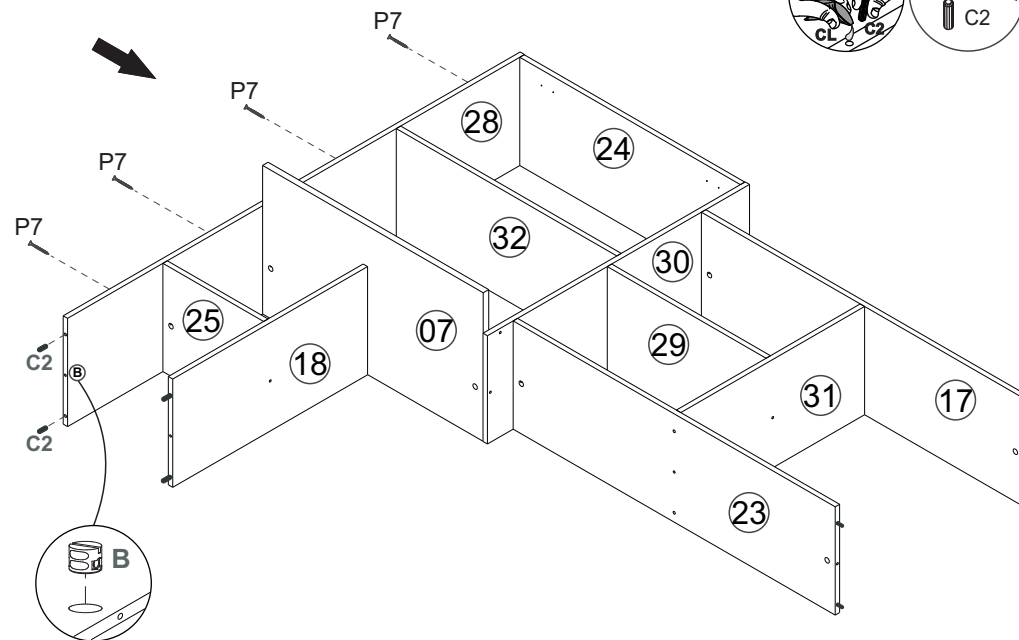

ATENÇÃO!!!! montadores e consumidores

* Ajustar o torque da parafusadeira para não danificar as peças escareando o parafuso *

ATENCIÓN!!!! montadores e consumidores

* Ajuste el torque del destornillador para no dañar las piezas avallanando el tornillo *

ATTENTION!!!! assemblers and consumers

* Adjust the torque of the screwdriver so as not to damage the parts by countersinking the screw *

www.decibal.com.br

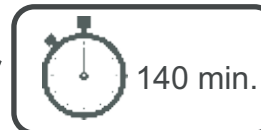

140 min.

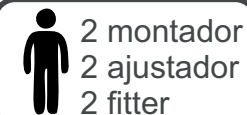

2 montador
2 ajustador
2 fitter

CO5006 - COZINHA

Manual de Montagem
 Assembly Instructions
 Instrucción de Montaje



19º

D C5

DOBRADIÇA/BISAGRA/HINGE D=26mm C=5

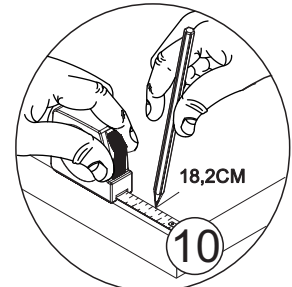
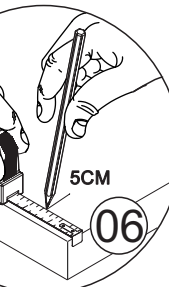
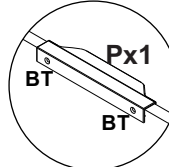
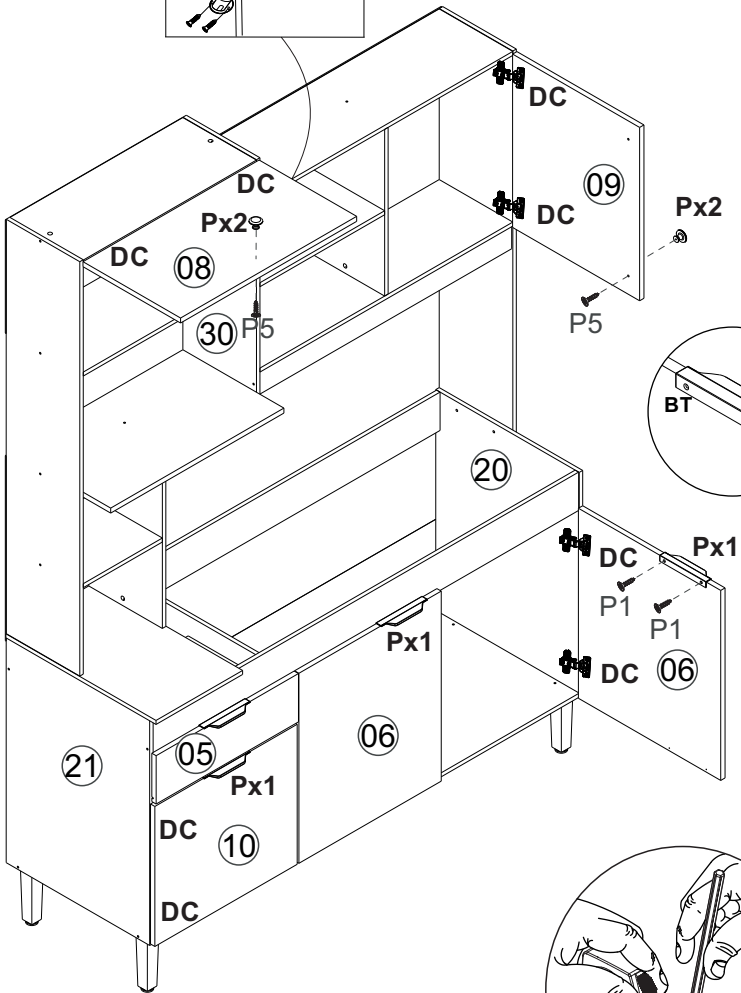
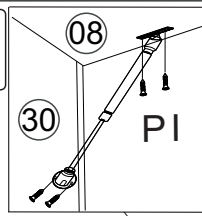
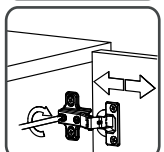
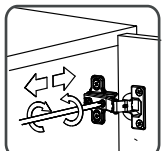
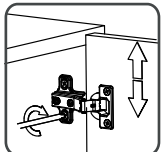
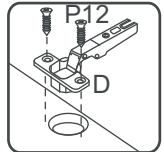
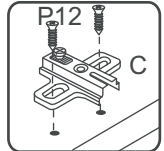

ATENÇÃO!!!!

MARCAÇÃO PRA O PRIMEIRO FURO DO PUXADOR
 MARCADO PARA EL PRIMER AGUJERO
 MARKING FOR THE FIRST HANDLE HOLE

PESO SUPORTADO/PESO SOPORTADO/ WEIGHT SUPPORTED

Fixação parede
 Fixed in the wall

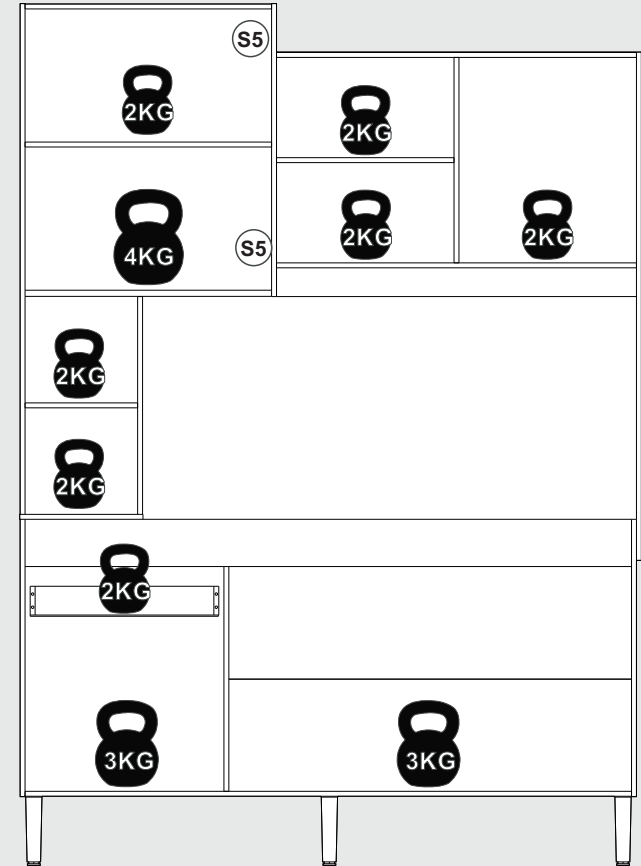
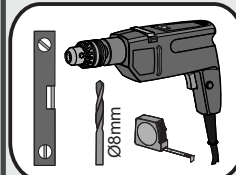
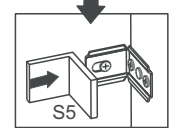
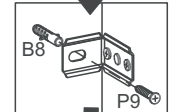
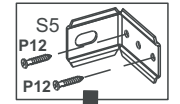

Ferramenta necessárias
 Necessary tools
 Herramientas necesarias





















CO5006 - COZINHA

Manual de Montagem
Assembly Instructions
Instrucción de Montaje

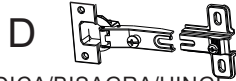

Ferragens/ Herrajes/ Hardware

		escala (1:1)	
LEGENDA	DESCRIÇÃO/DESCRIPCIÓN/DESCRIPTION	CÓDIGO	QUANT.
P7	 PARAFUSO/TORNILLO/SCREW 4X45	01318	29
PR1	 PREGO/CLAVO/NAIL 10X10	01330	120
C2	 CAVILHA/TARUGO/DOWEL 6X30 MM	01211	56
P1	 PARAFUSO/TORNILLO/SCREW 3,5X12	01328	30
PU	 PARAFUSO UNIÃO/UNIÓN DETORNILLO /SCREW UNION	01495	02
P5	 PARAFUSO/TORNILLO/SCREW 3,5X25	09955	02
P12	 PARAFUSO/TORNILLO/SCREW 3,5X13	09927	70
P6	 PARAFUSO/TORNILLO/SCREW 4X35	02032	02
P9	 PARAFUSO/TORNILLO/SCREW 6X50	03827	02

		escala (N/A)	
LEGENDA	DESCRIÇÃO/DESCRIPCIÓN/DESCRIPTION	CÓDIGO	QUANT.
CL	 COLA/PEGAMENTO/GLUE	01213	01
ET	 ETIQUETA LOGO DECIBAL/LABEL DECIBAL	01312	01
B8	 BUCHA/BUJE/BUCHING	01311	02
PL	 PERFIL/PROFILE/ 995MM	Wood/brc 11755	01
DC	 DOBRADIÇA/BISAGRA/HINGE D=26mm C=5mm	01268	10
S5	 SUPORTE AÉREO/APOYO AÉREO/AIR SUPPORT	03828 Wood 09647	02
Fx	 FIXADOR COSTA/FIJADOR FONDO/FIXER COAST	01331	10
B	 BUCJA/BUJE/BUCHING	02734	29
Ct1	 CANTONEIRA/PIEZA L/SHEET	03077	13
AD	 ADESIVO/ADHESIVO/ADHESIVE 15mm	Wood 09929	22

Medida em mm







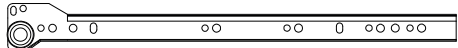

CO5006 - COZINHA

Manual de Montagem
Assembly Instructions
Instrucción de Montaje

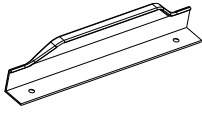



Escala (N/A)

LEGENDA	DESCRIÇÃO/DESCRIPCIÓN/DESCRIPTION	CÓDIGO	QUANT.
CR	 CORREDICA/CORREDERA/METALIC SLIDE LARG	01225	01
PE	 PÉ/PATA/FOOT (170MM)	11121 Cinza	05
Px1	 PUXADOR/PEGADOR/HAND (PUX COVER TOPO 128MM)	11984 CHAMPAGNE	04
Px2	 PUXADOR/PEGADOR/HANDLE (PUX GRACE PONTO RETRO)	11905 CHAMPAGNE	02
BT	 BATENTE/BATIENTE DE SILICONA/SILICONE STOP 8MM	02921	08
PI	 PISTÃO GÁS / PISTÓN DE GAS /GAS PISTON	03911 60N	01

Ferragens/ Herrajes/ Hardware

escala (1:1)

LEGENDA	DESCRIÇÃO/DESCRIPCIÓN/DESCRIPTION	CÓDIGO	QUANT.
Pr2	 PREGO/CLAVO/NAIL 13X15	01329	04
P8	 PARAFUSO/TORNILLO/SCREW 5X45	01320	05
P13	 PARAFUSO/TORNILLO/SCRE 4X22	10178	01

Relação de Peças/ Relación de Piezas/Parts List

Nº	CÓDIGO/COE	DESCRIÇÃO/DESCRIPCIÓN/DESCRIPTION	QTD/CANT	VOL.
1	0549598	BASE INF 1476X497X12MM	1,00	1
2	0549603	TRAVESSA TRS/TRAVIESA/TRVERSE 1476X115X12MM	1,00	1
3	0549621	TRAVESSA SUP/TRAVIESA/TRVERSE 876X70X12MM	1,00	1
4	0549610	TAMPO INF/TAPA/TOP 520X300X12MM	1,00	1
5	0549605	FRENTE GAVETA/FRENTE CAJÓN/DRAWER FRONT 493X145X15MM	1,00	1
6	0549604	PORTA INF MAIOR/PUERTA/DOOR 570X493X15MM	2,00	1
7	0549616	PRATELEIRA MICRO/ESTANTE/SHELF 600X350X15MM	1,00	1
8	0549620	PORTA BASCULANTE/PUERTA/DOOR 610X338X15MM	1,00	1
9	0549619	PORTA SUP/PUERTA/DOOR 520X400X15MM	1,00	1
10	0549606	PORTA INF MENOR/PUERTA/DOOR 493X420X15MM	1,00	1
11	0549607	LATERAL GAV/LATERAL CAJÓN/DRAWER 350X70X12MM	2,00	1
12	0549608	BATENTE/REVÉS CAJÓN/DRAWER BACK 435X70X12MM	1,00	1
13	0549609	FUNDO DE GAVETA/FONDO CÁJON/ DRAWER BOTTOM 458X355X2,8MM	1,00	1
14	0549623	COSTA SUP MENOR/REVÉS/BACK 615X340X2,8MM	1,00	1
15	0549637	COSTA INF MENOR/REVÉS/BACK 570X500X2,8MM	1,00	1
16	0549624	COSTA INT/REVÉS/BACK 555X294X2,8MM	1,00	1
17	0549626	TAMPO SUP MAIOR/TAPA/TOP 876X255X12MM	1,00	1
18	0549618	DIVISÓRIA INT/DIVIDER 530X255X12MM	1,00	1
19	0549601	TRAVESSA FRT/TRAVIESA/TRVERSE 1476X115X12MM	1,00	1
20	0549599	LATERAL DIR/LATERAL/SIDE 675X497X12MM	1,00	1
21	0549600	LATERAL ESQ/LATERAL/SIDE 675X497X12MM	1,00	1
22	0549602	DIVISÓRIA INF/DIVIDER 547X497X12MM	1,00	1
23	0549614	BASE SUP 876X255X12MM	1,00	1
24	0549613	TAMPO SUP/TAPA/TOP 600X255X12MM	1,00	1
25	0549629	PRATELEIRA MENOR/ESTANTE/SHELF 274X255X12MM	1,00	1
26	0549622	COSTA SUP MAIOR/REVÉS/BACK 892X520X2,8MM	1,00	1
27	0549625	COSTA INF MAIOR/REVÉS/BACK 996X285X2,8MM	2,00	1
28	0549612	LATERAL ESQ SUP/LATERAL/SIDE 1243X225X12MM	1,00	2
29	0549628	PRAT SUP MAIOR/ESTANTE/SHELF 432X225X12MM	1,00	2
30	0549615	DIVISÓRIA SUP/DIVIDER 713X225X12MM	1,00	2
31	0549627	DIVISÓRIA SUP DIR/DIVIDER 500X225X12MM	1,00	2
32	0549617	BASE SUP MENOR 600X225X12MM	1,00	2
33	0549611	LATERAL DIR SUP/LATERAL/SIDE 1237X225X12MM	1,00	2

Medida em mm

