



**MANUAL DE MONTAGEM  
ASSEMBLY INSTRUCTIONS  
INSTRUCCIONES DE MONTAJE**

**COD BR: BE 19, BMU 119**



# Sumário Summary Resumen

Introdução Introduction Introducción	.....	3
Antes de começar Before starting Antes de comenzar	.....	4
Evite acidentes Avoid accidents Evitar accidentes	.....	4
Dimensões e ferramentas Dimensions and tools Dimensiones y herramientas	.....	5
Identificação das peças Identifying parts Identificación de las piezas	.....	6
Acessórios incluídos na caixa Hardware included in box Accesorios incluidos en la caja	.....	7
Montagem do móvel Furniture assembly Montaje del mueble	.....	8

## Introdução Introduction Introducción

Leia atentamente este manual e siga os passos indicados para que o produto não perca a garantia e também para uma perfeita montagem.

Read this manual and follow the steps in order to keep the guarantee and also for the perfect fit.

Lea este manual y siga los pasos para que el producto no pierda la garantía y también para el ajuste perfecto.

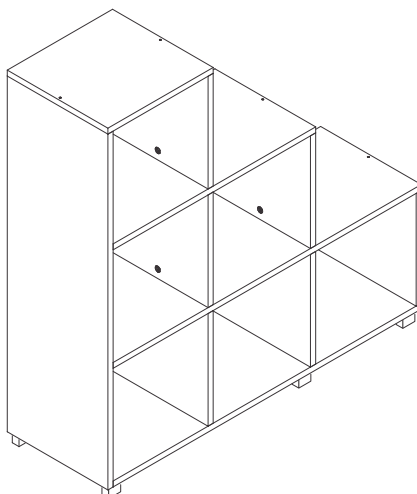

## Antes de começar Before starting Antes de comenzar

Antes de começar a montagem prepare o ambiente, deixando-o completamente limpo e com bom espaço para iniciar o trabalho.

Prepare the room before starting the assembly, leaving it completely clean and the area in good condition to start the work.

Antes de comenzar el montaje preparar el ambiente, dejándolo completamente limpio y con bueno espacio para comenzar el trabajo.

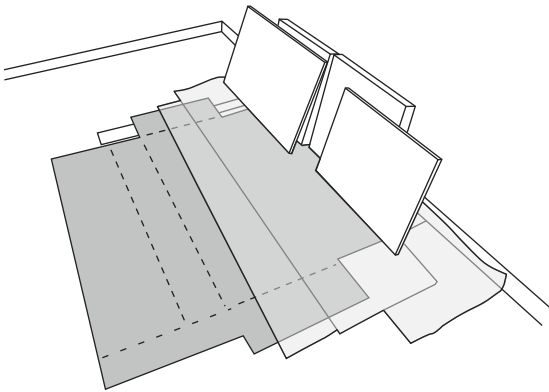

Utilize o papelão da própria embalagem para separar e apoiar as peças retiradas das caixas.

Use the cardboard of the packaging to separate and support the parts removed from the boxes.

Utilice el cartón de la embalaje para separar y apoyar las piezas desmontadas de las cajas.

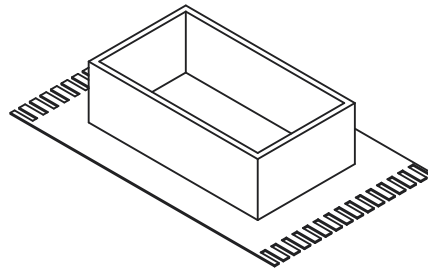

Forre a área de montagem com um cobertor ou tapete. Assim, você evita avarias nas peças durante o processo de montagem.

Cover the assembly area with a blanket or carpet to avoid damaging the parts during the assembly process.

Cubrir la zona de ensamble con una manta o alfombra. De este modo, se evitan daños en las piezas durante el proceso de montaje.



## Evite acidentes Avoid accidents Prevenir accidentes

Solicitamos observar atentamente as orientações de montagem como: fixação do produto na parede, colocação de cola em locais específicos necessários, o peso suportado pelo produto, etc...

We request you to carefully observe the assembly instructions as: fixing the product on the wall, adding glue in needed and specific places, product weight limit, etc.

Pedimos que lea atentamente las instrucciones, principalmente las informaciones de fijación del producto en la pared, colocación de pegamento en local específico y necesario, el peso soportado por el producto etc...

Não escale ou se apoie no móvel.

Do not climb or lean on the furniture.

No se suba ni se apoye en el mueble.

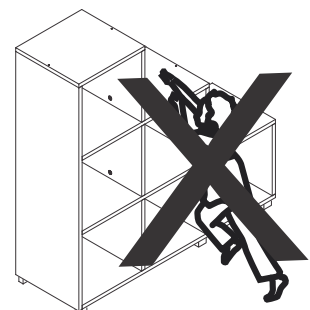

Dimensões e ferramentas  
Dimensions and tools  
Dimensiones y herramientas

L: 915 A:950 P: 294 mm

Dimensions:

W: 36.02 H: 37.40 D: 11.57 inches

Dimensiones:

L: 915 A: 950 P: 294 mm

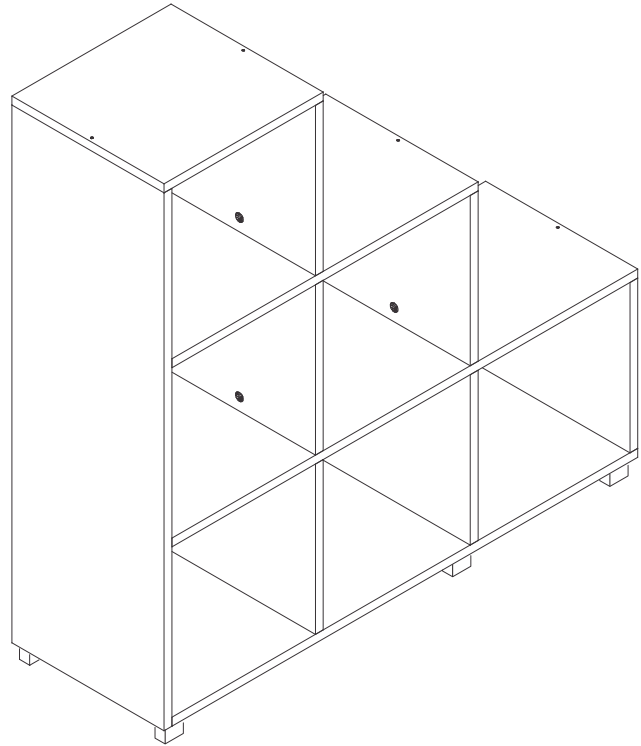

---

Limpeza  
Cleanig  
Limpieza

Pano levemente umedecido com água, seguido de pano seco, não utilizar produtos químico ou abrasivos.  
Slightly dampened cloth and after a dry cloth, do not use chemicals or abrasives.  
Solamente utilizar un paño húmedo y después un paño seco, no utilice productos químicos o abrasivos.

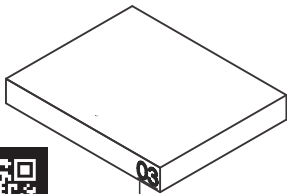

**UTILIZE ALCOOL APENAS PARA REMOVER O NUMERO DAS PEÇAS**  
**USE ALCOHOL ONLY TO REMOVE PART NUMBERS**  
**UTILICE ALCOHOL SOLAMENTE PARA ELIMINAR EL NUMERO DE LAS PIEZAS**

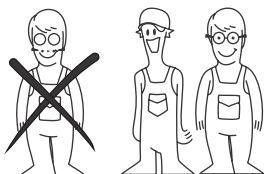

Para facilitar a montagem, utilize uma parafusadeira elétrica.  
To improve assembly, use an eletronic screwdriver.  
Para facilitar el armado, utilice un destornillador eléctrico.

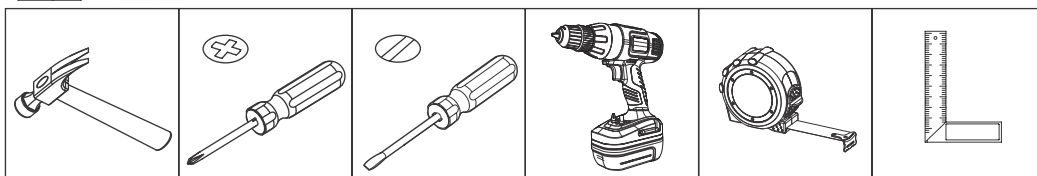

# COD BR: BE 19, BMU 119

PEÇA	DESCRIÇÃO	QUANT.
001	BASE	1
002	LATERAL ESQUERDA	1
003	PRATELEIRA MAIOR	1
004	TAMPO	1
005	PRATELEIRA MENOR	1
006	LATERAL DIREITA	1
007	DIVISÓRIA A	4
008	DIVISÓRIA B	1

PART	DESCRIPTION	QTY
001	BASE	1
002	LEFT SIDE	1
003	LONGER SHELF	1
004	TOP	1
005	LOWER SHELF	1
006	RIGHT SIDE	1
007	DIVISION A	4
008	DIVISION B	1

PIEZA	DESCRIPCIÓN	CANTIDAD
001	BASE	1
002	LATERAL IZQUIERDA	1
003	ESTANTE MAYOR	1
004	TAPA	1
005	ESTANTE MENOR	1
006	LATERAL DERECHA	1
007	DIVISORIO A	4
008	DIVISORIO B	1

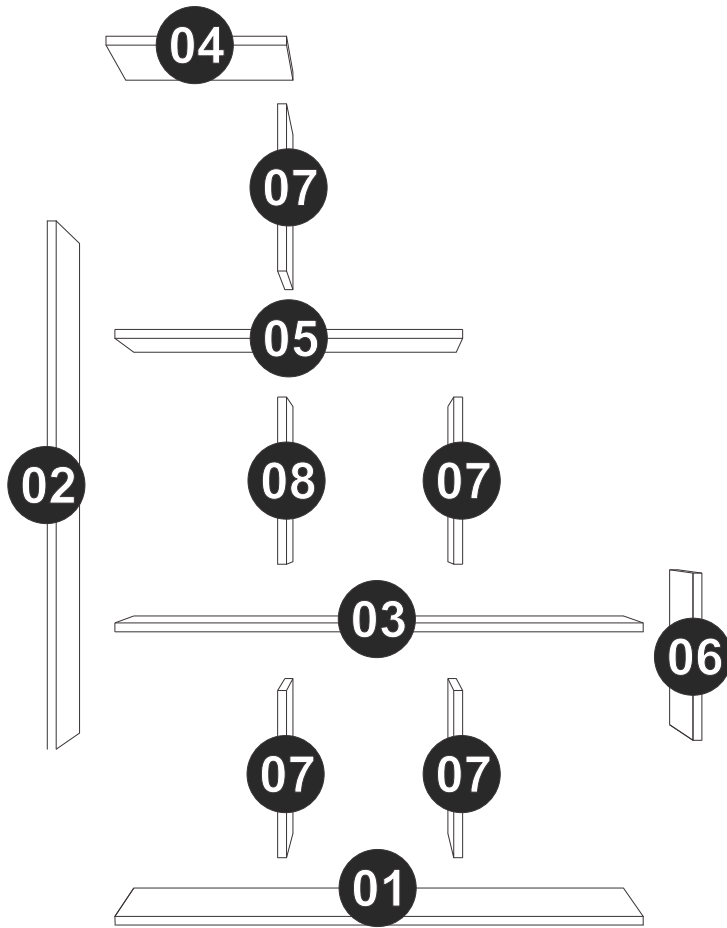

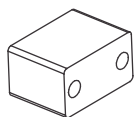

PÉS x 6  
FEET x 6  
PIES x 6

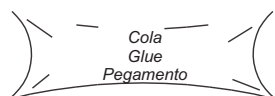

EF 000008 x 1



EF 000248 X 9  
3,5X14 CP



EF 000033 x 20  
8x30



EF 000404 X 12  
3,5x25 CC



EF 000132 x 8  
4X50 CC



EF 000468 X 3  
6X50 CF



GIZ x 01  
CHALK x 01  
TIZA x 01

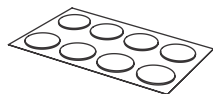

TAPA FUROS x 16  
STICKER x 16  
TAPAS PLÁSTICAS x 16



EF 000016 x 3

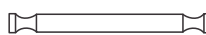

EF 000067 X 3



EF 000094 X 2



EF 000216 X 8

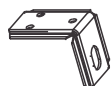

EF 000242 X 3



CAPA PLÁSTICA X 3  
PLASTIC COVER X 3  
CAPA PLASTICA X 3



EF 000247 X 6

Utilize para medir as ferragens.

Utilice para medir el herraje.

Use for measuring the hardware.

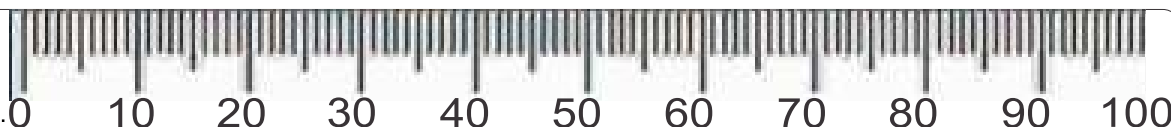

**Garantia (exclusivo para o Brasil/exclusivo de Brasil/exclusive to Brazil):**

A garantia dos produtos fabricados pela BRV Móveis, abrange eventuais defeitos-vícios de fabricação, no prazo estabelecido pelo código de Defesa do Consumidor, em seu artigo 26.II. o qual prevê a garantia de 90 (noventa) dias.

**A** = 3KG - 6.61LB

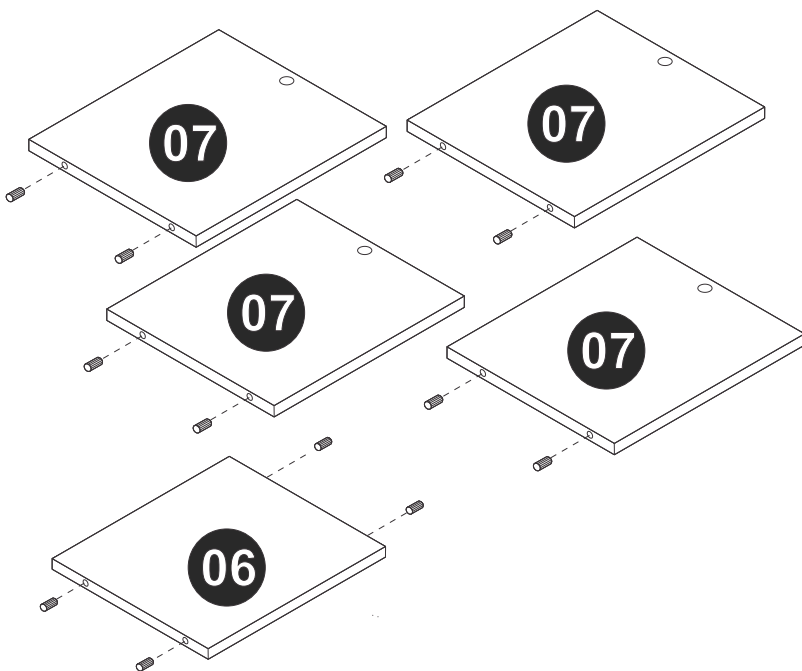
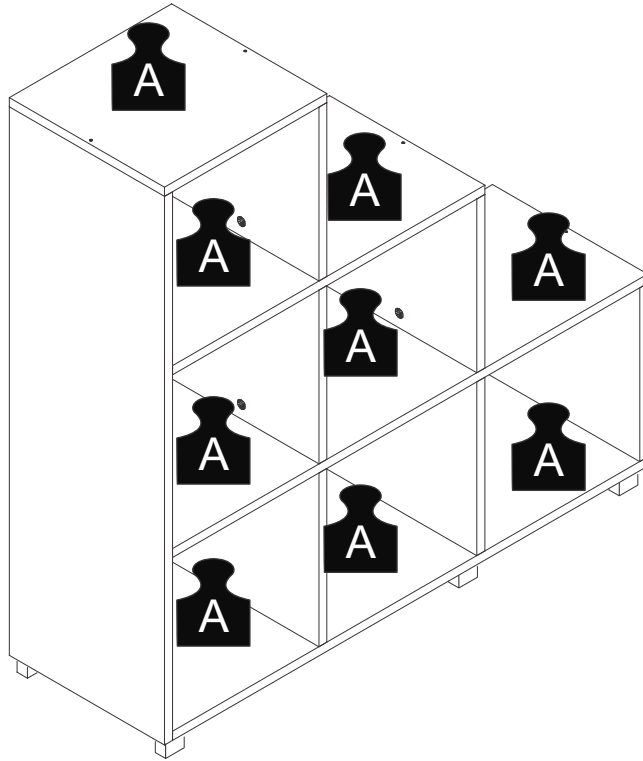

**PASSO 1 / STEP 1 / PASO 1**

Utilize a cola (EF 000008) antes de inserir a ferragem EF 000033 nas peças 06 e 07.

Use the glue (EF 000008) before connecting hardware EF 000033 into pieces 06 and 07.

Utilice el pegamento (EF 000008) antes de añadir el herraje EF 000033 en las piezas 06 y 07.

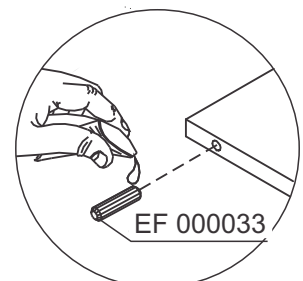

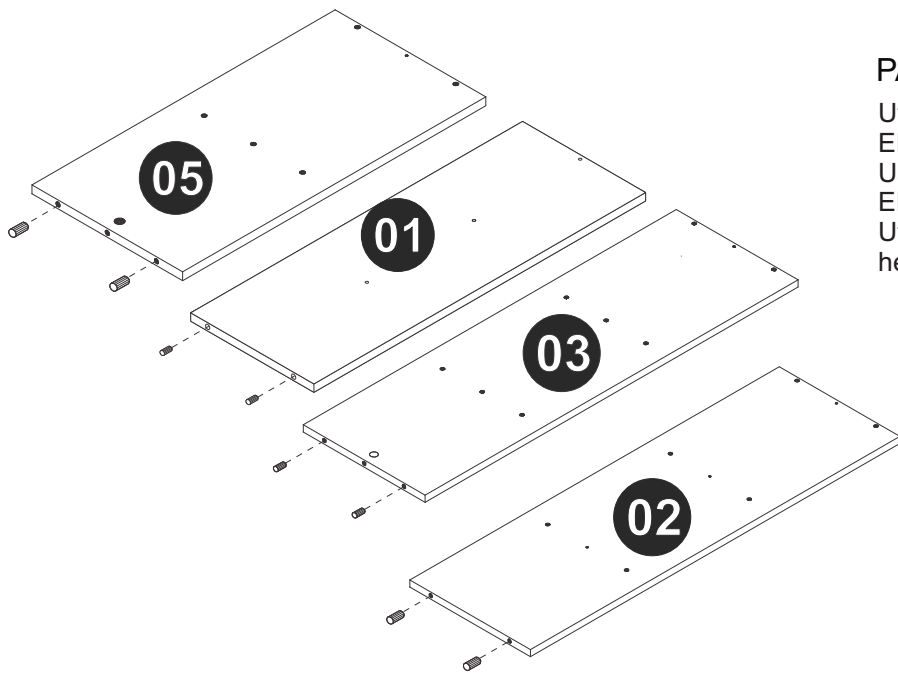

## PASSO 2 / STEP 2 / PASO 2

Utilize a cola (EF 000008) antes de inserir a ferragem EF 000033 nas peças 01, 02, 03 e 05.  
 Use the glue (EF 000008) before connecting hardware EF 000033 into pieces 01, 02, 03 and 05.  
 Utilice el pegamento (EF 000008) antes de añadir el herraje EF 000033 en las piezas 01, 02, 03 y 05.

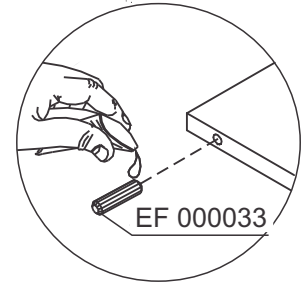

## PASSO 3 / STEP 3 / PASO 3

Fixe a ferragem EF 000094 na peça 02.  
 Fix hardware EF 000094 into piece 02.  
 Fije el herraje EF 000094 en la pieza 02.

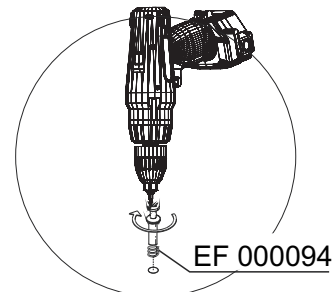
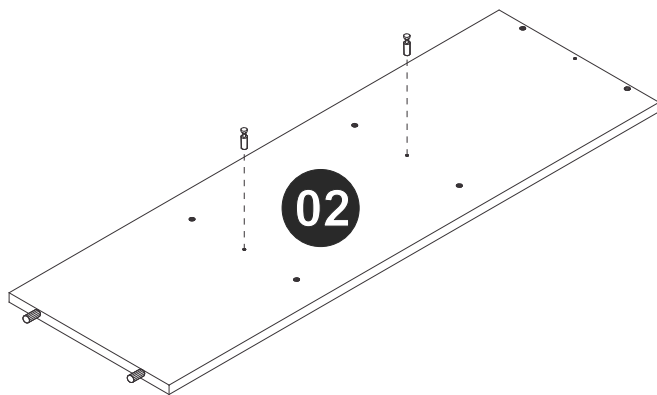

## PASSO 4 / STEP 4/ PASO 4

Conecte as peças 01, 06 e 07 utilizando a ferragem EF 000132.  
 Connect pieces 01, 06 and 07 using hardware EF 000132.  
 Junte las piezas 01, 06 y 07 utilizando el herraje EF 000132.

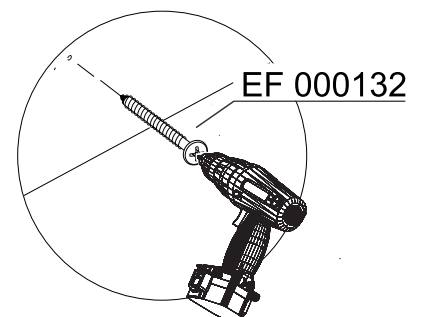
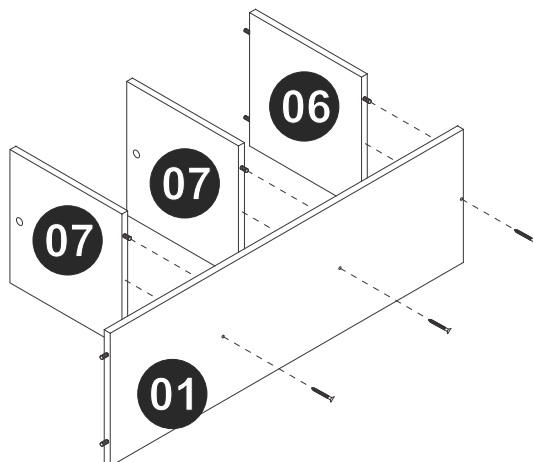

### PASSO 5 / STEP 5 / PASO 5

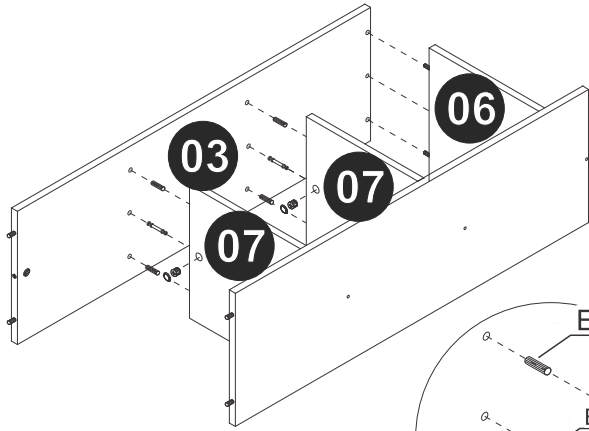

Insira a ferragem EF 000067 e EF 000247 nos locais indicados e encaixe a peça 03 na parte montada no passo anterior, aperte usando a ferragem EF 000215, de acordo com a imagem.

Insert hardware EF 000067 and EF 000247 in the indicated places and fit piece 03 at the pieces assembled previously, use hardware EF 000215 to tighten.

Añade los herrajes EF 000067 y EF 000247 en los lugares indicados. Junte la pieza 03 en la parte armada en el paso anterior, utilice el herraje EF 000215 para apretar.

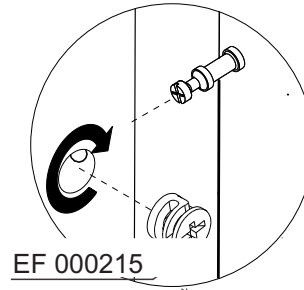
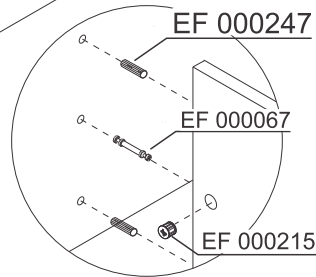

### PASSO 6 / STEP 6 / PASO 6

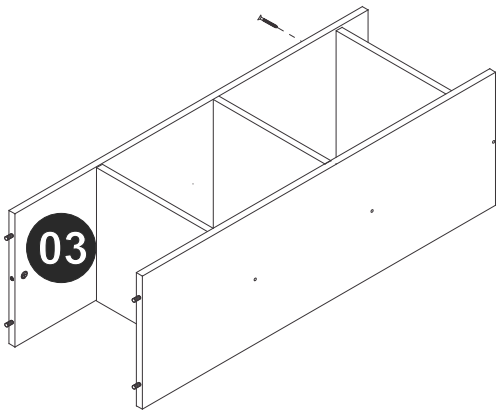

Use a ferragem EF 000132 para fixar a peça 03.

Use hardware EF 000132 to fix piece 03.

Utilice el herraje EF 000132 para fijar la pieza 03.

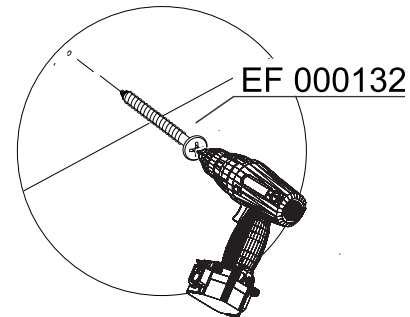

### PASSO 7 / STEP 7 / PASO 7

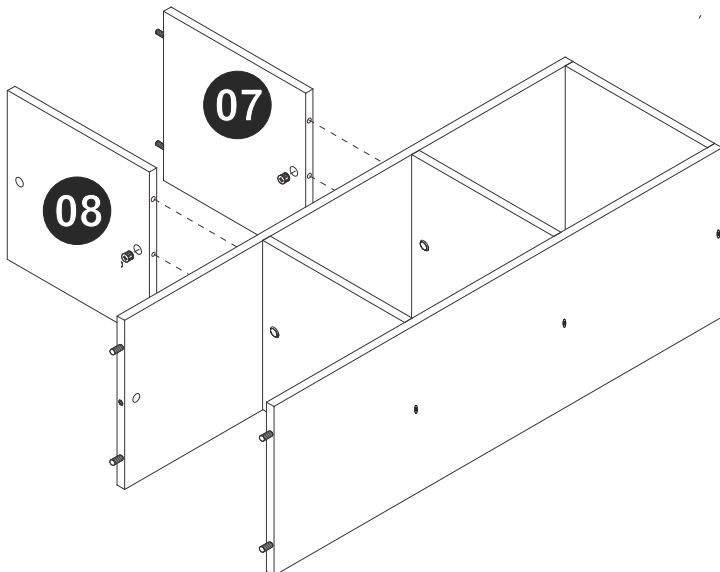

Conecte as peças 07 e 08 na parte montada no passo anterior, insira a ferragem EF 000215 e gire para apertar.

Connect pieces 07 and 08 to the part assembled on previous step, insert hardware EF 000215 and turn to tighten.

Junte las piezas 07 y 08 a la parte armada en el paso anterior, añada el herraje EF 000215 y gire para apretar.

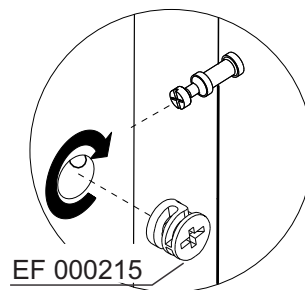

### PASSO 8 / STEP 8 / PASO 8

Insira a ferragem EF 000067 e EF 000247 nos locais indicados. Encaixe a peça 05 na parte montada no passo anterior, aperte usando a ferragem EF 000215, de acordo com a imagem. Insert hardware EF 000067 and EF 000247 in the indicated places. Fit piece 05 at the pieces assembled previously, use hardware EF 000215 to tighten. Añade los herrajes EF 000067 y EF 000247 en los lugares indicados. Junte la pieza 05 en la parte armada en el paso anterior, utilice el herraje EF 000215 para apretar.

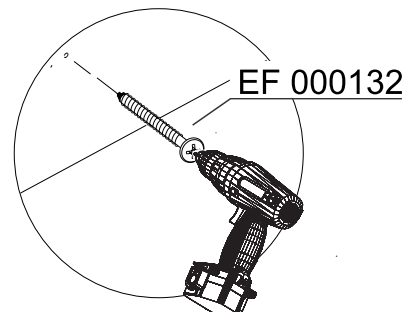
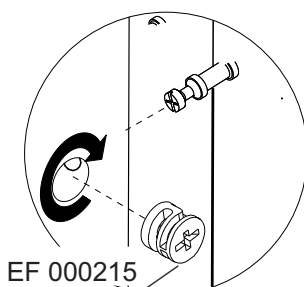
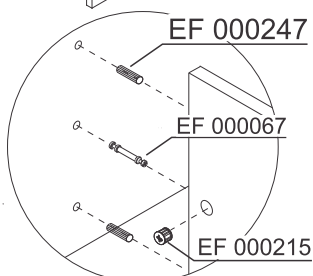
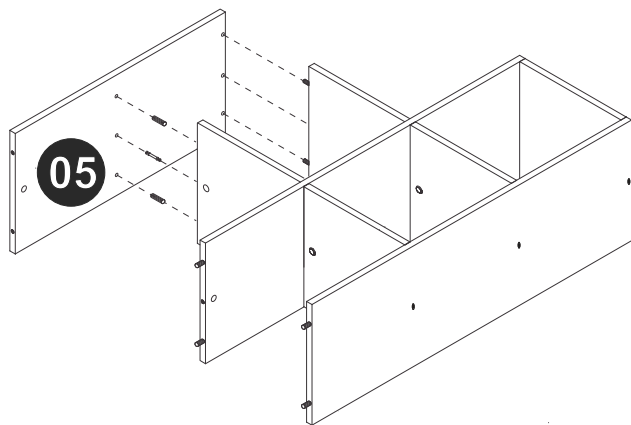

### PASSO 9 / STEP 9 / PASO 9

Use a ferragem EF 000132 para fixar a peça 05. Use hardware EF 000132 to fix piece 05. Utilice el herraje EF 000132 para fijar la pieza 05.

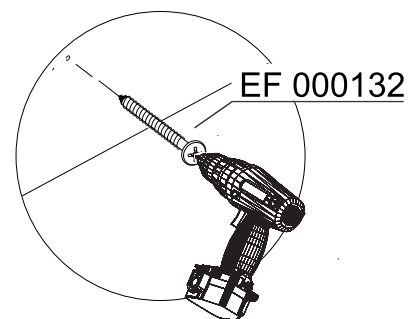
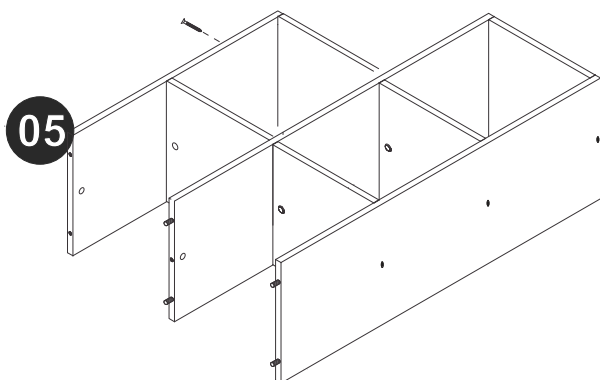

### PASSO 10 / STEP 10 / PASO 10

Encaixe as peças 07 e 02 na parte montada no passo anterior, insira a ferragem EF 000215 e gire para apertar. Fit pieces 07 and 02 at the pieces assembled previously, insert hardware EF 000215 and turn to tighten. Junte las piezas 07 y 02 en la parte armada en el paso anterior, añada el herraje EF 000215 y gire para apretar.

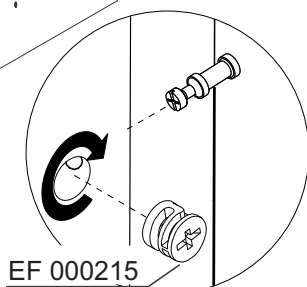
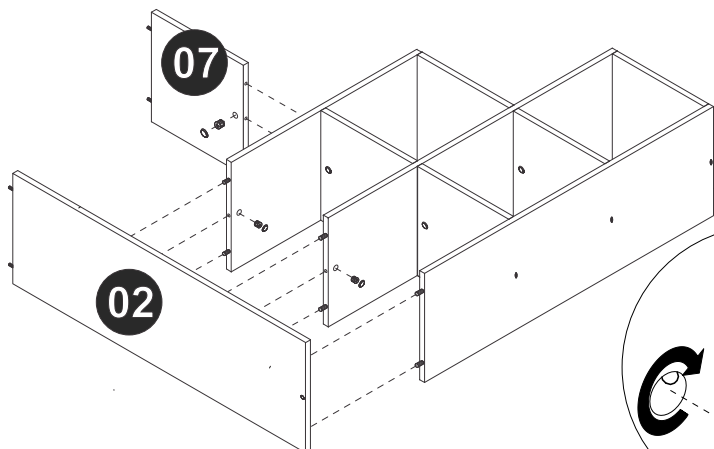

### PASSO 11 / STEP 11 / PASO 11

Use a ferragem EF 000132 para fixar a peça 02 à peça 01.  
Use hardware EF 000132 to fix piece 02 to piece 01.  
Utilice el herraje EF 000132 para fijar la pieza 02 a la pieza 01.

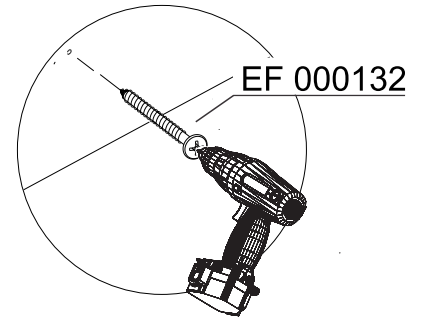
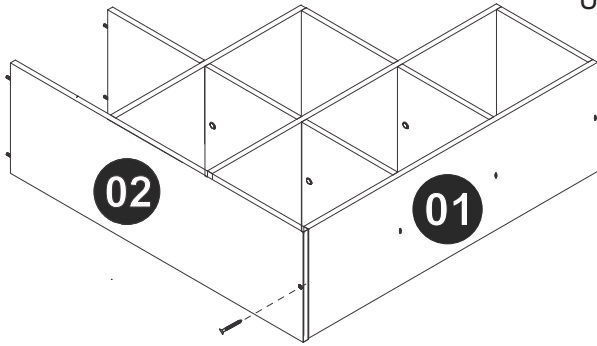

### PASSO 12 / STEP 12 / PASO 12

Use a ferragem EF 000132 para fixar a peça 04.  
Use hardware EF 000132 to fix piece 04.  
Utilice el herraje EF 000132 para fijar la pieza 04.

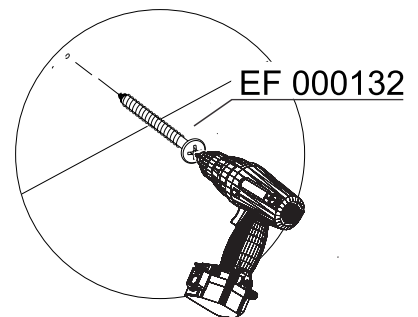
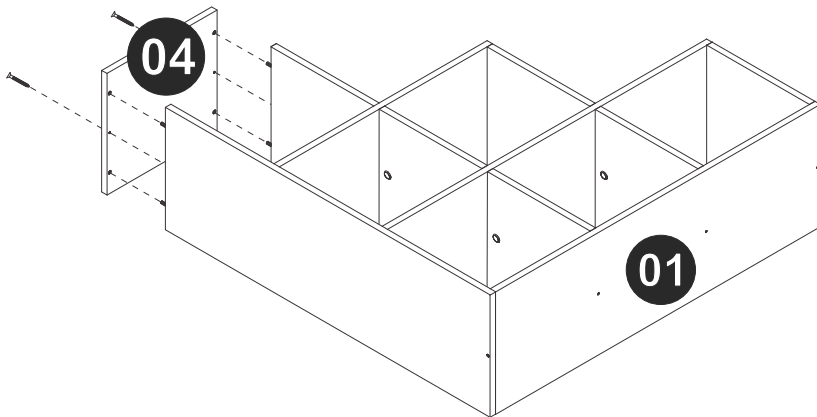

Opção para piso  
Floor option  
Opción para piso

### PASSO 13 / STEP 13 / PASO 13

Fixe os pés na peça 01 utilizando a ferragem EF 000404.  
Fix the feet at piece 01 using hardware EF 000404.  
Fije los pies en la pieza 01 utilizando el herraje EF 000404.

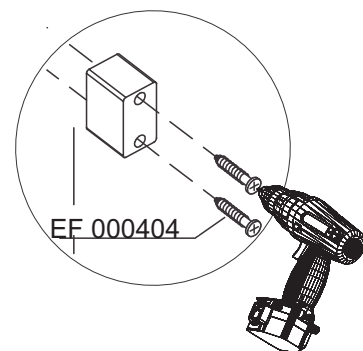
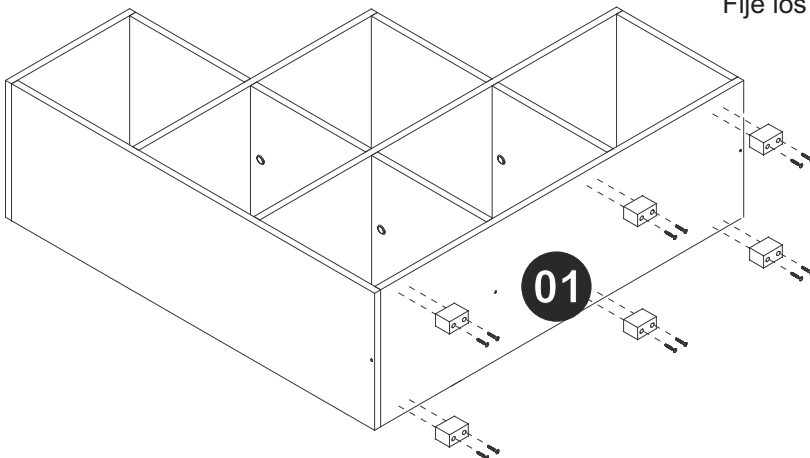

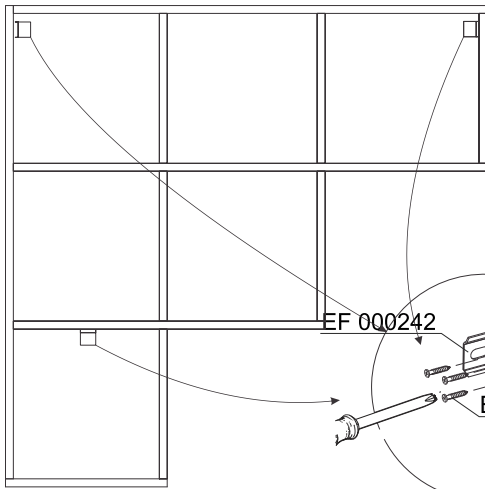

Opção para parede  
Wall option  
Opción para pared

### PASSO 14 / STEP 14 / PASO 14

Fixe a ferragem EF 000242 ao móvel usando a ferragem EF 000248  
Fix hardware EF 000242 at the furniture, using hardware EF 000248  
Fije el herraje EF000242 en el mueble utilizando el herraje EF 000248

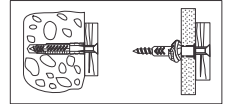
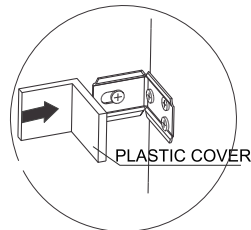
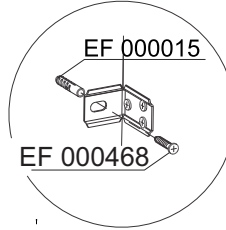

Perfure a parede com uma broca de 6 mm. Insira a ferragem EF 000015 na parede. Fixe os móveis na parede usando o hardware EF 000468.

Drill de wall with an 6mm drill bit. Insert hardware EF 000015 into the wall. Fixe the furniture in the wall using hardware Ef000246. Drill de wall with an 6mm drill bit. Insert hardware EF 000015 into the wall. Fixe the furniture in the wall using hardware EF 000468.

Fije el mueble en la pared utilizando el herraje EF 000468.

### PASSO 15 / STEP 15 / PASO 15

Use os tapa furos para cobrir os parafusos aparentes.  
Use o giz para dar o acabamento final ao produto.  
Use stickers to cover apparent screws.  
Use the chalk to give the final finish on the product.  
Utilice los tapa huecos para cubrir los tornillos aparentes.  
Utilice la tiza para dar el acabado final al producto.

