



**MANUAL DE MONTAGEM
ASSEMBLY INSTRUCTIONS
INSTRUCCIONES DE MONTAJE**

COD BR: BBN 13

Sumário Summary Resumen

Introdução Introduction Introducción	3
Antes de começar Before starting Antes de comenzar	4
Evite acidentes Avoid accidents Evitar accidentes	4
Dimensões e ferramentas Dimensions and tools Dimensiones y herramientas	5
Identificação das peças Identifying parts Identificación de las piezas	6
Acessórios incluídos na caixa Hardware included in box Accesorios incluidos en la caja	7
Montagem do móvel Furniture assembly Montaje del mueble	8

Introdução Introduction Introducción

Leia atentamente este manual e siga os passos indicados para que o produto não perca a garantia e também para uma perfeita montagem.

Read this manual and follow the steps in order to keep the guarantee and also for the perfect fit.

Lea este manual y siga los pasos para que el producto no pierda la garantía y también para el ajuste perfecto.

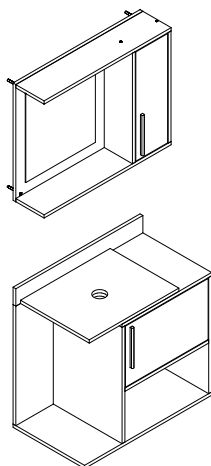

Antes de começar Before starting Antes de comenzar

Antes de começar a montagem prepare o ambiente, deixando-o completamente limpo e com bom espaço para iniciar o trabalho.

Prepare the room before starting the assembly, leaving it completely clean and the area in good condition to start the work.

Antes de comenzar el montaje preparar el ambiente, dejándolo completamente limpio y con bueno espacio para comenzar el trabajo.

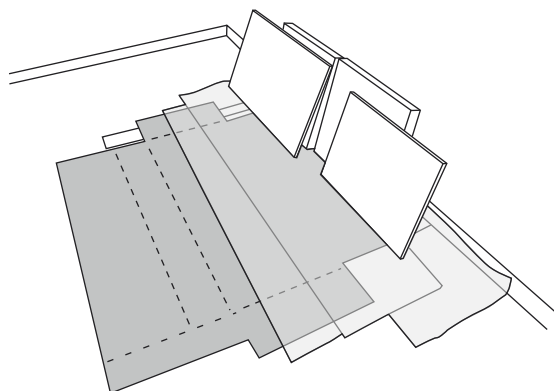

Utilize o papelão da própria embalagem para separar e apoiar as peças retiradas das caixas.

Use the cardboard of the packaging to separate and support the parts removed from the boxes.

Utilice el cartón de la embalaje para separar y apoyar las piezas desmontadas de las cajas.

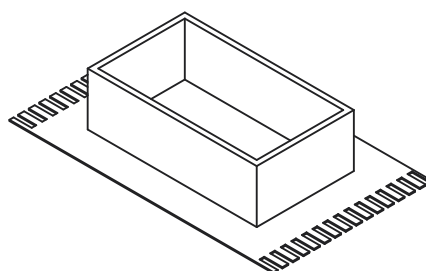

Forre a área de montagem com um cobertor ou tapete. Assim, você evita avarias nas peças durante o processo de montagem.

Cover the assembly area with a blanket or carpet to avoid damaging the parts during the assembly process.

Cubrir la zona de ensamble con una manta o alfombra. De este modo, se evitan daños en las piezas durante el proceso de montaje.



Evite acidentes Avoid accidents Prevenir accidentes

Solicitamos observar atentamente as orientações de montagem como: fixação do produto na parede, colocação de cola em locais específicos necessários, o peso suportado pelo produto, etc...

We request you to carefully observe the assembly instructions as: fixing the product on the wall, adding glue in needed and specific places, product weight limit, etc.

Pedimos que lea atentamente las instrucciones, principalmente las informaciones de fijación del producto en la pared, colocación de pegamento en local específico y necesario, el peso soportado por el producto etc...

Não escale ou se apoie no móvel.

Do not climb or lean on the furniture.

No se suba ni se apoye en el mueble.

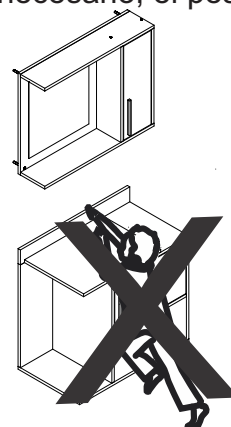

Dimensões e ferramentas
 Dimensions and tools
 Dimensiones y herramientas

Dimensões:

L: 675 A: 540 P: 165 mm

Dimensions:

W: 26.57 H: 21.25 D: 6.49 inches

Dimensiones:

L: 675 A: 540 P: 165 mm

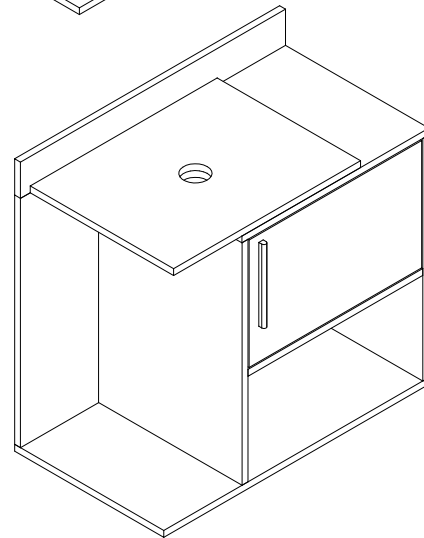
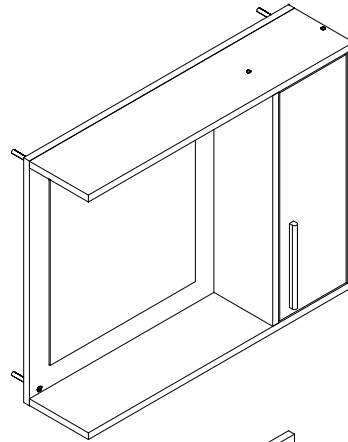

Dimensões:

L: 675 A: 710 P: 380 mm

Dimensions:

W: 26.57 H: 27.95 D: 14.96 inches

Dimensiones:

L: 675 A: 710 P: 380 mm

Limpeza
 Cleanig
 Limpieza



Pano levemente umedecido com água, seguido de pano seco, não utilizar produtos químico ou abrasivos.
 Slightly dampened cloth and after a dry cloth, do not use chemicals or abrasives.
 Solamente utilizar un paño húmedo y después un paño seco, no utilice productos químicos o abrasivos.

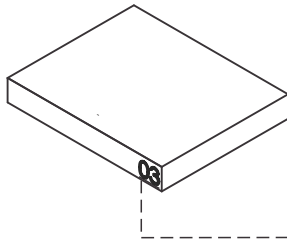

UTILIZE ALCOOL APENAS PARA REMOVER O NUMERO DAS PEÇAS
USE ALCOHOL ONLY TO REMOVE PART NUMBERS
UTILICE ALCOHOL SOLAMENTE PARA ELIMINAR EL NUMERO DE LAS PIEZAS

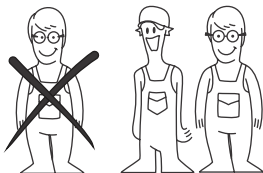

Para facilitar a montagem, utilize uma parafusadeira elétrica.
 To improve assembly, use an eletronic screwdriver.
 Para facilitar el armado, utilice un destornillador eléctrico.

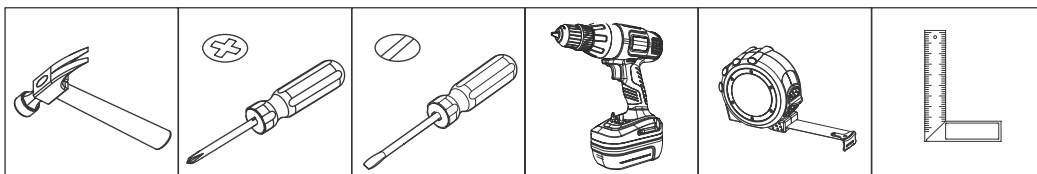

COD BR: BBN 13

PEÇA	DESCRIÇÃO	QUANT.
001	BASE BALCÃO	1
002	TAMPO SUPERIOR BALCÃO	1
003	TAMPO INFERIOR BALCÃO	1
004	LATERAL DIREITA BALCÃO	1
005	LATERAL ESQUERDA BALCÃO	1
006	PRATELEIRA BALCÃO	1
007	COSTA BALCÃO	1
008	VISTA BALCÃO	1
009	PORTA BALCÃO	1
010	TAMPO AÉREO	1
011	BASE AÉREO	1
012	COSTA AÉREO	1
013	LATERAL DIREITA AÉREO	1
014	LATERAL ESQUERDA AÉREO	1
015	PRATELEIRA AÉREO	2
016	PORTA AÉREO	1

PART	DESCRIPTION	QTY
001	CABINET BASE	1
002	CABINET UPPER TOP	1
003	CABINET LOWER TOP	1
004	CABINET RIGHT SIDE	1
005	CABINET LEFT SIDE	1
006	CABINET SHELF	1
007	CABINET BACK	1
008	CABINET DETAIL	1
009	CABINET DOOR	1
010	TOP CABINET TOP	1
011	TOP CABINET BASE	1
012	TOP CABINET BACK	1
013	TOP CABINET RIGHT SIDE	1
014	TOP CABINET LEFT SIDE	1
015	TOP CABINET SHELF	2
016	TOP CABINET DOOR	1

PIEZA	DESCRIPCIÓN	CANTIDAD
001	BASE ARMARIO	1
002	TAPA SUPERIOR ARMARIO	1
003	TAPA INFERIOR ARMARIO	1
004	LATERAL DERECHA ARMARIO	1
005	LATERAL IZQUIERDA ARMARIO	1
006	REPISA ARMARIO	1
007	REVÉS ARMARIO	1
008	DETALLE ARMARIO	1
009	PUERTA ARMARIO	1
010	TAPA AÉREO	1
011	BASE AÉREO	1
012	REVÉS AÉREO	1
013	LATERAL DERECHA AÉREO	1
014	LATERAL IZQUIERDA AÉREO	1
015	REPISA AÉREO	2
016	PUERTA AÉREO	1

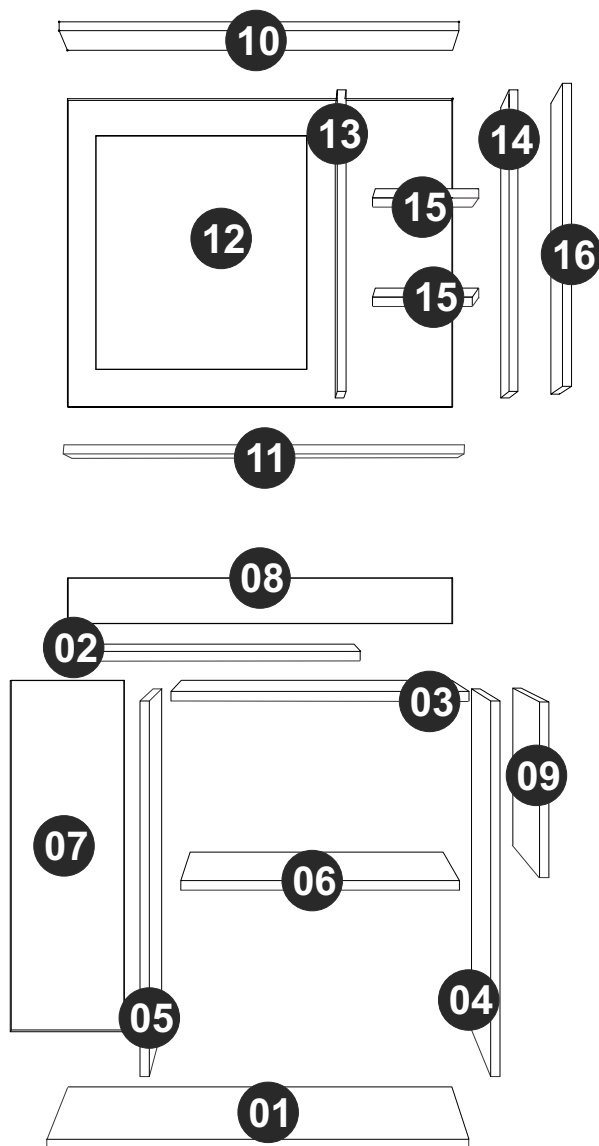

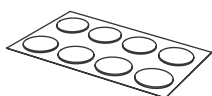

TAPA FUROS x 20
STICKER x 20
TAPAS PLÁSTICAS x 20



EF 000132 x 18
4X50 CC



EF 000106 x 28
3,5X14 CC



EF 000033 x 32
8x30



GIZ x 01
CHALK x 01
TIZA x 01



EF 000216 X 10



EF 000094 X 8



EF 000146 x 8
5X60 CC



CAPA PLASTICA x 4
PLASTIC COVER x 4
CAPA PLASTICA x 4



EF 000016 X 8



PUXADOR x 2
HANDLE x 2
MANIJA x 2

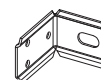

EF 000242 x 4



EF 000025 X 4



EF 000404 x 8
3,5X25 CC



EF 000724 x 2
8x40



EF 000750 X 1

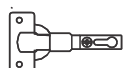

EF 000043 X 4



EF 000696 x 2
8x45



SUPORTE PLÁSTICO x 1
PLASTIC SUPPORT x 1
SOPORTE PLASTICO x 1

Utilize para medir as ferragens.

Utilice para medir el herraje.

Use for measuring the hardware.

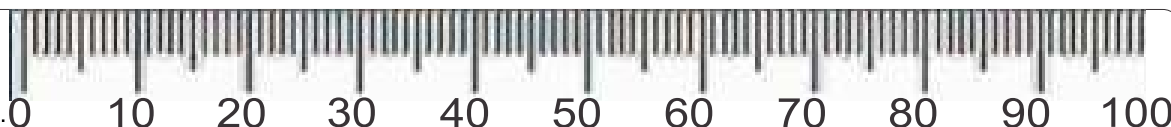

Garantia (exclusivo para o Brasil/exclusivo de Brasil/exclusive to Brazil):

A garantia dos produtos fabricados pela BRV Móveis, abrange eventuais defeitos-vícios de fabricação, no prazo estabelecido pelo código de Defesa do Consumidor, em seu artigo 26.II. o qual prevê a garantia de 90 (noventa) dias.

A = 6KG - 13.22LB

B = 2KG - 4.40LB

C = 1KG - 2.20LB

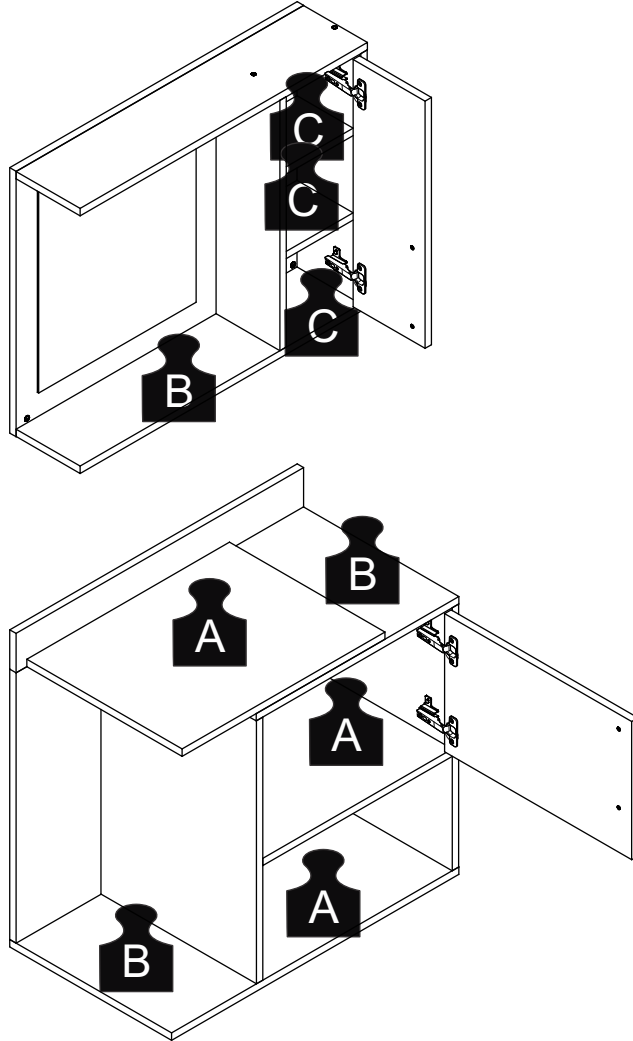

PASSO 1 / STEP 1 / PASO 1

Fixe a ferragem EF 000094 nas peças 03, 04 e 05.
Fix hardware EF 000094 in pieces 03, 04 and 05.
Fije el herraje EF 000094 en las piezas 03, 04 y 05.

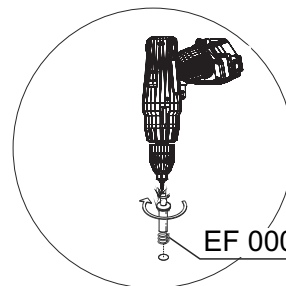
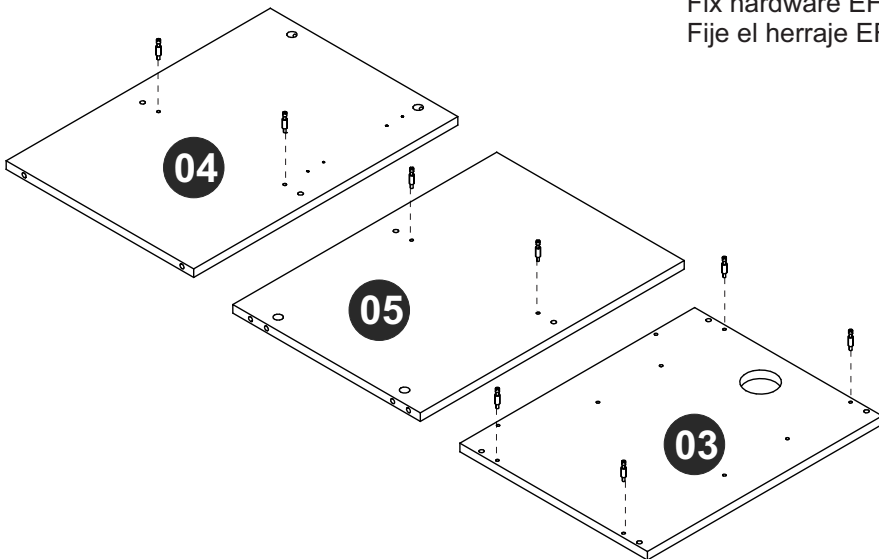

PASSO 2 / STEP 2 / PASO 2

Insira a ferragem EF 000033 nas peças 10, 13, 14 e 15.
Insert hardware EF 000033 in pieces 10, 13, 14 and 15.
Añade el herraje EF 000033 en las piezas 10, 13, 14 y 15.

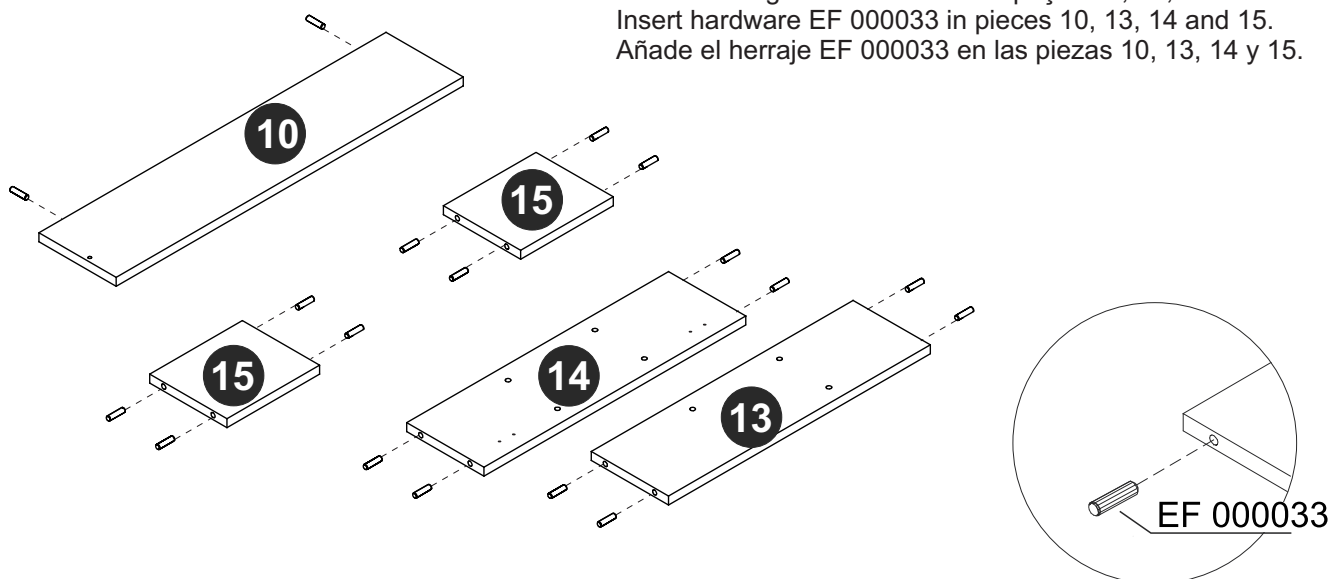

PASSO 3 / STEP 3 / PASO 3

Insira a ferragem EF 000033 nas peças 04, 05, 06 e 07.
Insert hardware EF 000033 in pieces 04, 05, 06 and 07.
Añade el herraje EF 000033 en las piezas 04, 05, 06 y 07.

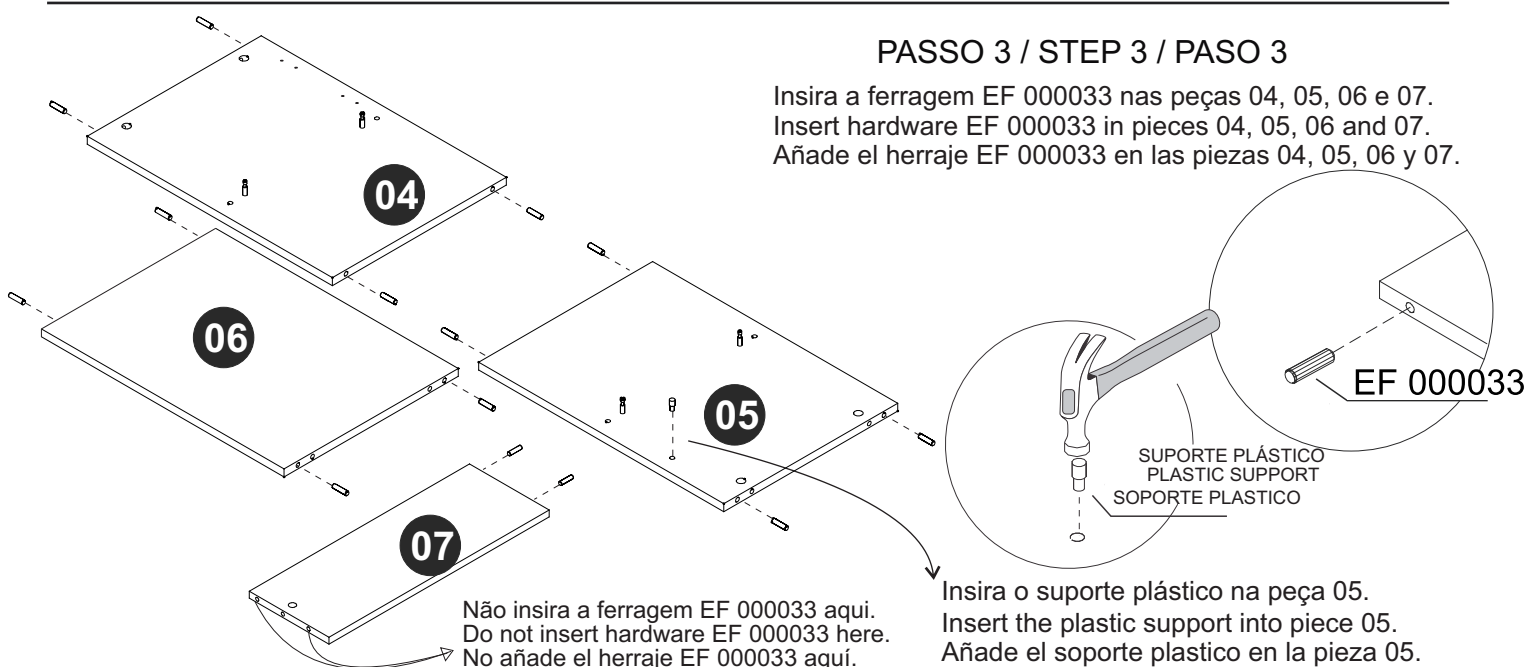

PASSO 4 / STEP 4 / PASO 4

Fixe a ferragem EF 000025 nas peças 04 e 14 utilizando a ferragem EF 000106.
Attach hardware EF 000025 on pieces 04 and 14 using hardware EF 000106.
Fije el herraje EF 000025 en las piezas 04 y 14 utilizando el herraje EF 000106.

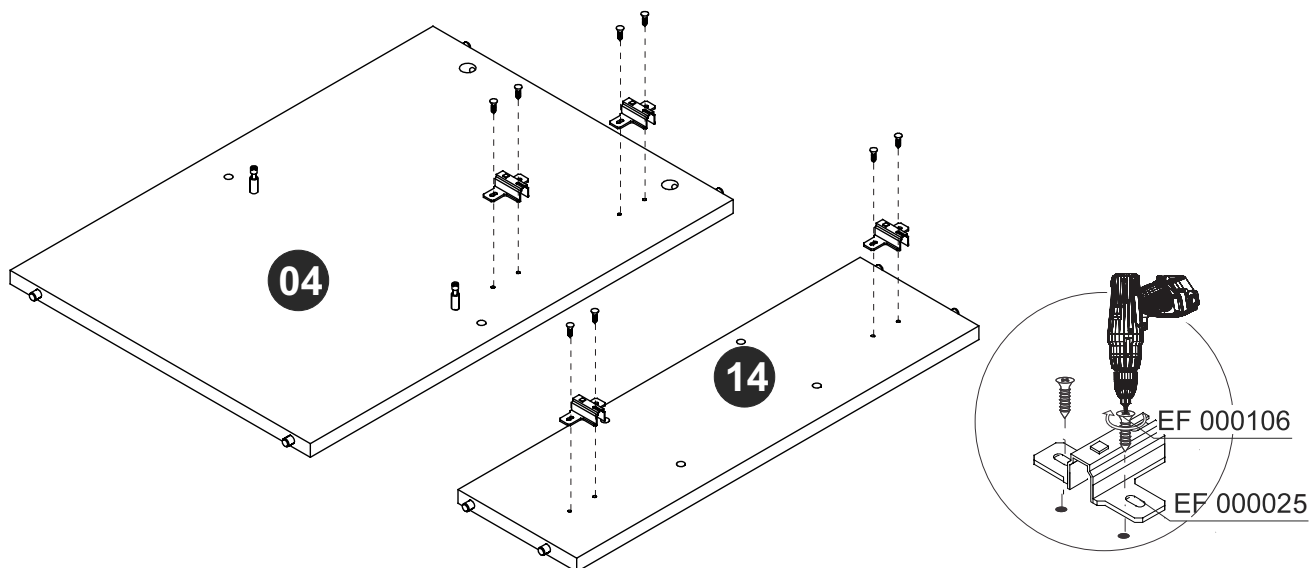

PASSO 5 / STEP 5 / PASO 5

Fixe a ferragem EF 000043 nas peças 09 e 16 utilizando a ferragem EF 000106.
Fixe o puxador usando a ferragem EF 000112.

Attach hardware EF 000043 on pieces 09 and 16 using hardware EF 000106. Attach the handle using hardware EF 000112.

Fije el herraje EF 000043 en las piezas 09 y 16 utilizando el herraje EF 000106.
Fije la manija utilizando el herraje EF 000112.

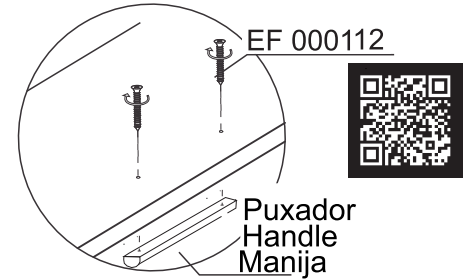
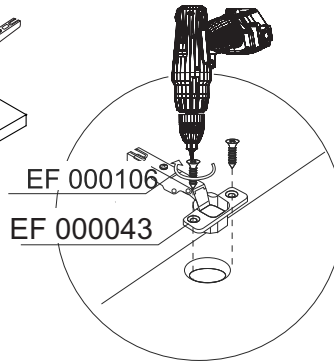
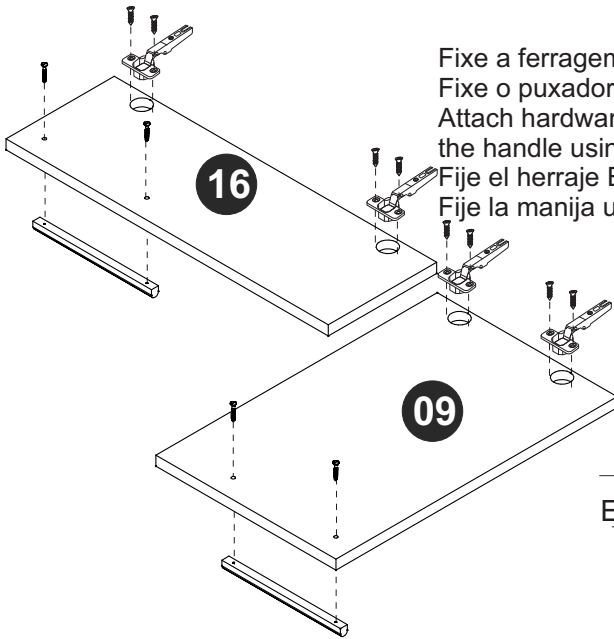

PASSO 6 / STEP 6 / PASO 6

Use a ferragem EF 000106 para fixar a ferragem EF 000242 nas peças 04 e 05.

Use hardware EF 000106 to attach hardware EF 000242 in pieces 04 and 05.

Utilice el herraje EF 000106 para fijar el herraje EF 000242 en las piezas 04 y 05.

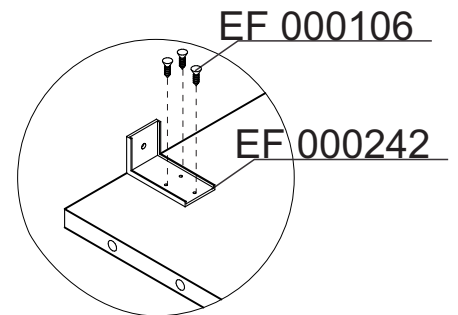
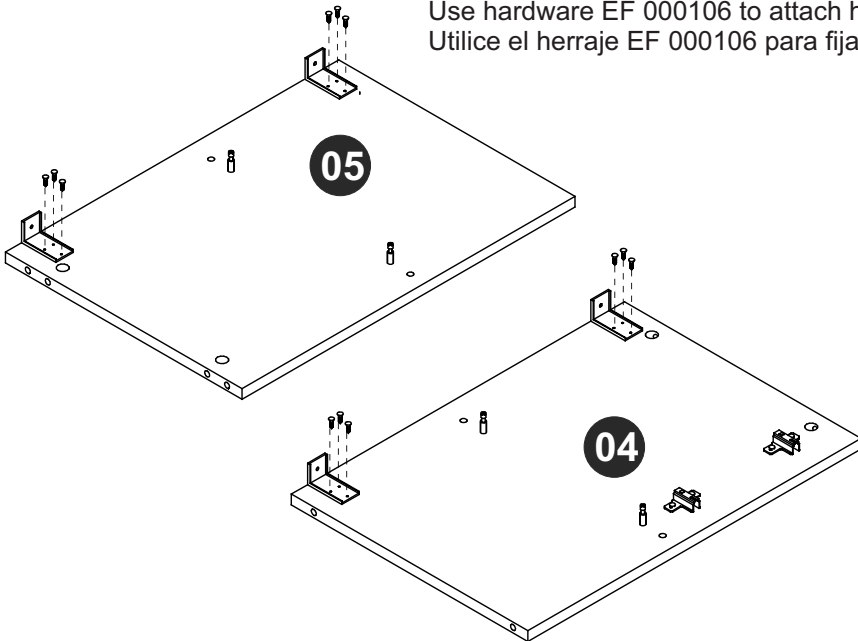

PASSO 7 / STEP 7 / PASO 7

Use a ferragem EF 000404 para conectar as peças 02 e 03.

Use hardware EF 000404 to connect pieces 02 and 03.

Utilice el herraje EF 000404 para juntar las piezas 02 y 03.

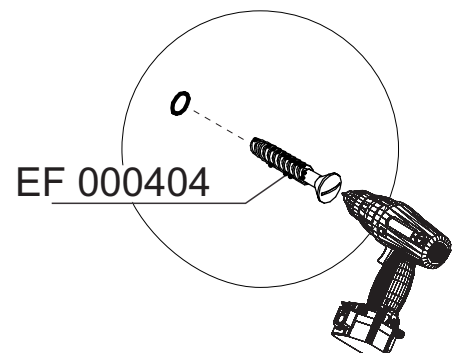
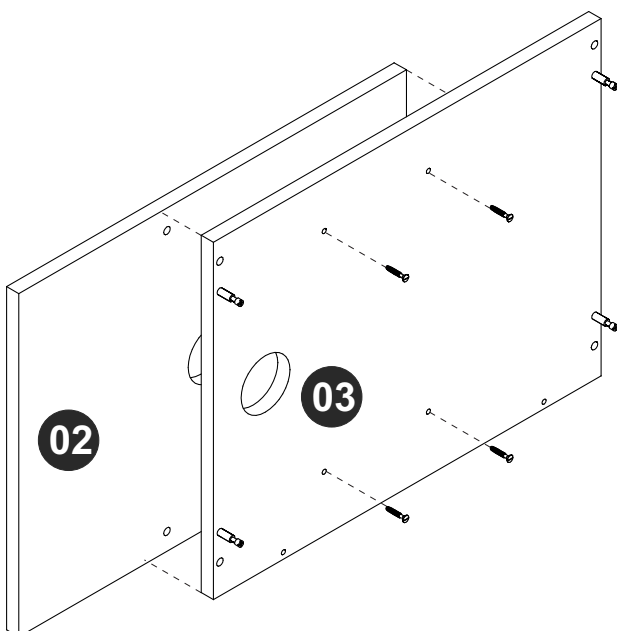

PASSO 8 / STEP 8 / PASO 8

Conecte a peça 08 utilizando ferragem EF 000132.
Connect piece 08 using hardware EF 000132.
Junte la pieza 08 utilizando el herraje EF 000132.

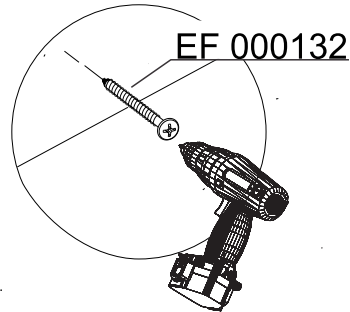
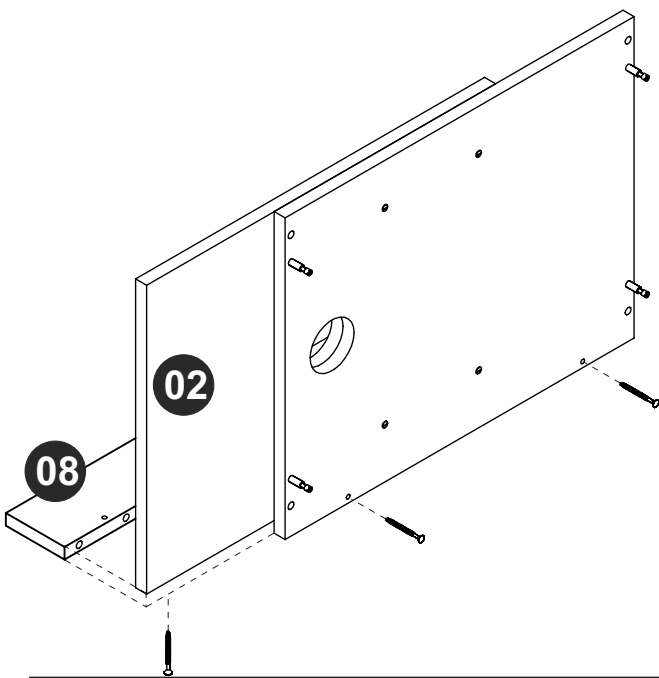

PASSO 9 / STEP 9 / PASO 9

Conecte as peças 04, 05 e 06, insira a ferragem EF 000216 e gire para apertar.
Connect pieces 04, 05 and 06, insert hardware EF 000216 and turn to tighten.
Junte las piezas 04, 05 y 06, añade el herraje EF 000216 y gire para apretar.

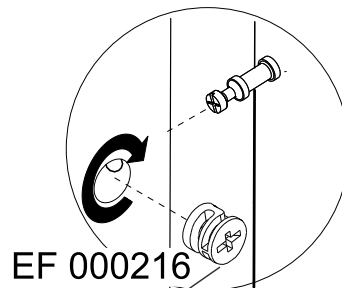
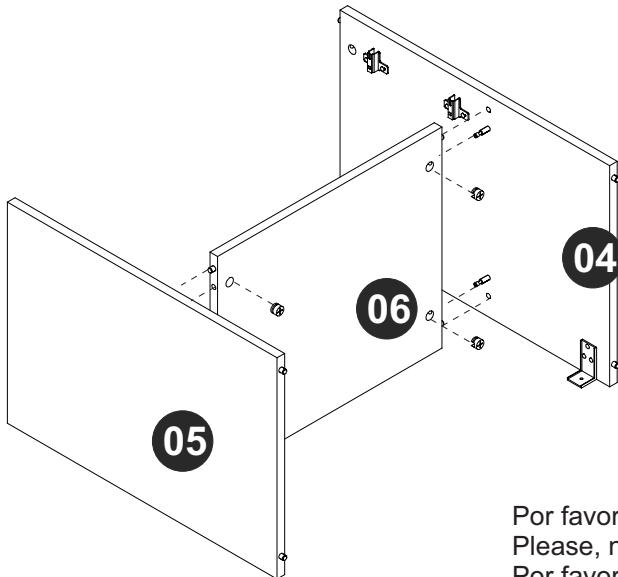

EF 000025

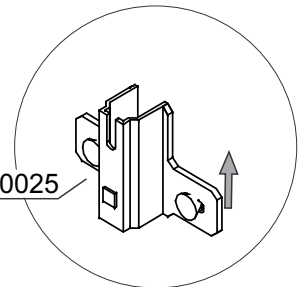

Por favor, observe a posição da ferragem EF 000025.
Please, note hardware EF 000025 position.
Por favor, observe la posición del herraje EF 000025.

PASSO 10 / STEP 10 / PASO 10

Insira a ferragem EF 000696 para conectar as partes montadas nos passos 8 e 9, insira a ferragem EF 000216 e gire para apertar.
Insert hardware EF 000696 to connect the parts assembled in steps 8 and 9, insert hardware EF 000216 and turn to tighten.
Añade el herraje EF 000696 para juntar las partes armadas en los pasos 8 y 9, añade el herraje EF 000216 y gire para apretar.

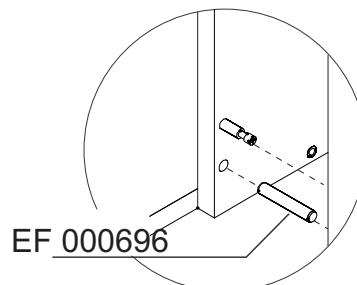
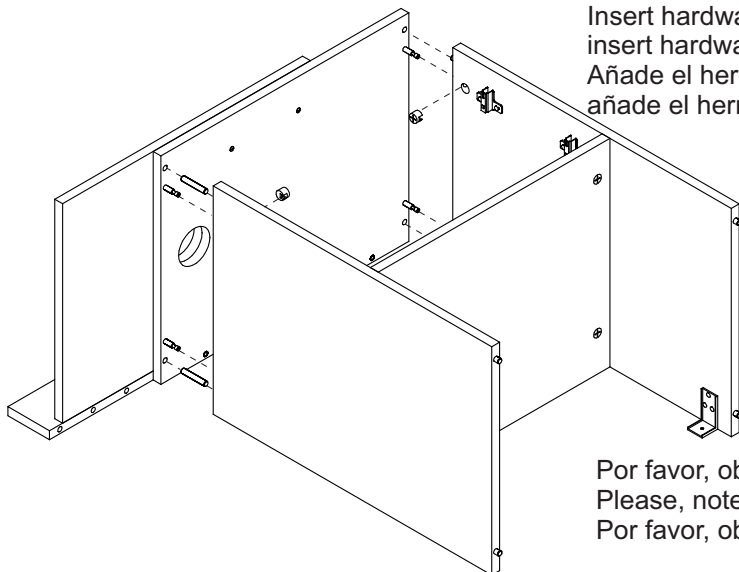

EF 000025

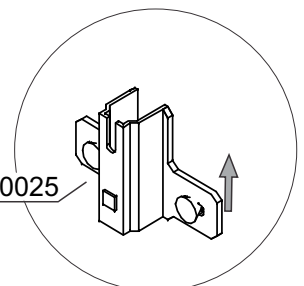

Por favor, observe a posição da ferragem EF 000025.
Please, note hardware EF 000025 position.
Por favor, observe la posición del herraje EF 000025.

PASSO 11 / STEP 11/ PASO 11

Insira as ferragens EF 000750 e EF 000724 para conectar as peça 07, insira a ferragem EF 000216 e gire para apertar.
Insert hardware EF 000750 and EF 000724 to connect piece 07, insert hardware EF 000216 and turn to tighten.
Añade los herrajes EF 000750 y EF 000724 para juntar la pieza 07, añade el herraje EF 000216 y gire para apretar.

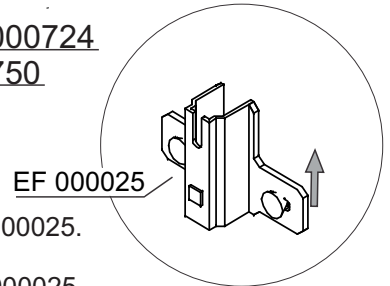
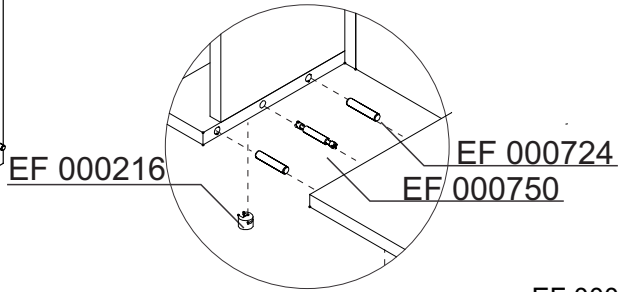
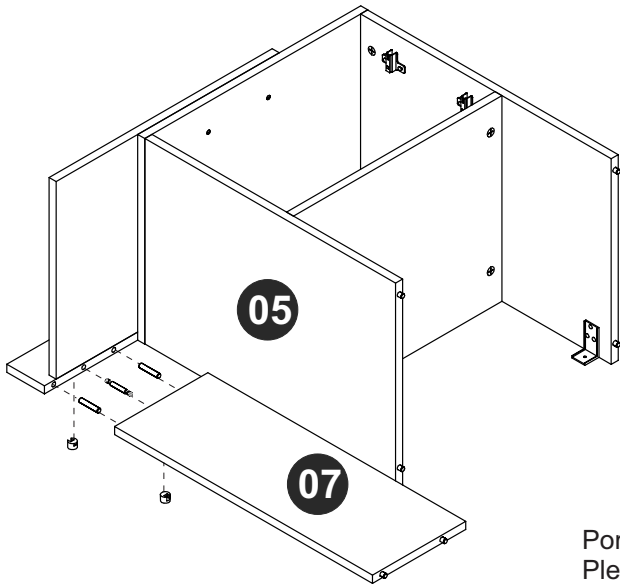

Por favor, observe a posição da ferragem EF 000025.
Please, note hardware EF 000025 position.
Por favor, observe la posición del herraje EF 000025.

PASSO 12 / STEP 12 / PASO 12

Conecte a peça 01 utilizando ferragem EF 000132.
Connect piece 01 using hardware EF 000132.
Junte la pieza 01 utilizando el herraje EF 000132.

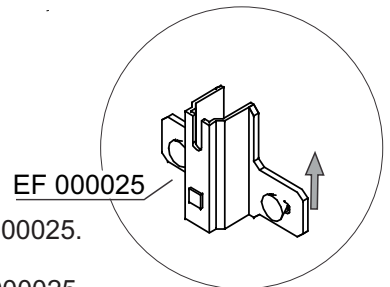
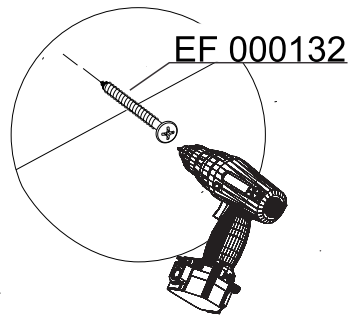
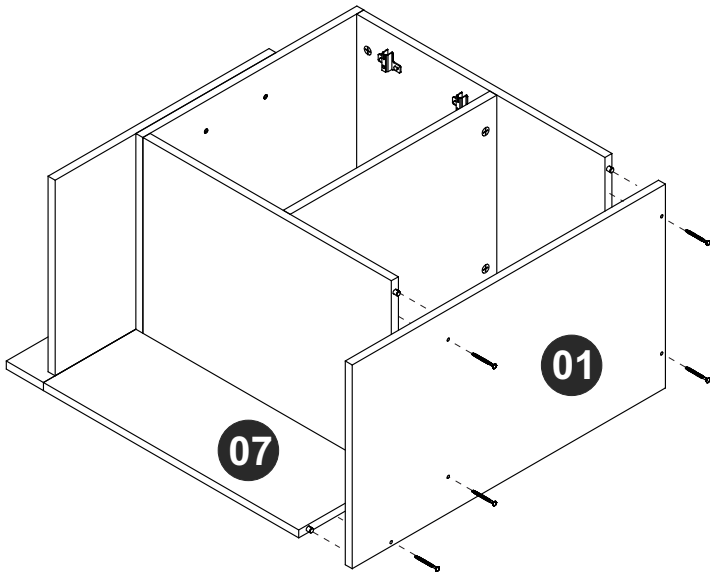

Por favor, observe a posição da ferragem EF 000025.
Please, note hardware EF 000025 position.
Por favor, observe la posición del herraje EF 000025.

PASSO 13 / STEP 13 / PASO 13

Encaixas peças 13, 14 e 15.
Fit pieces 13, 14 and 15.
Junte las piezas 13, 14 y 15.

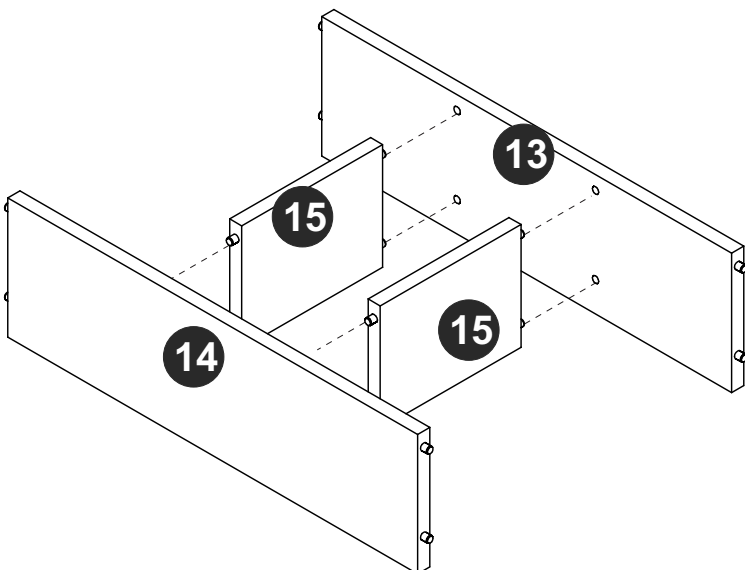

PASSO 14 / STEP 14/ PASO 14

Conecte as peças 10 e 11 utilizando ferragem EF 000132.
Connect pieces 10 and 11 using hardware EF 000132.
Junte las piezas 10 y 11 utilizando el herraje EF 000132.

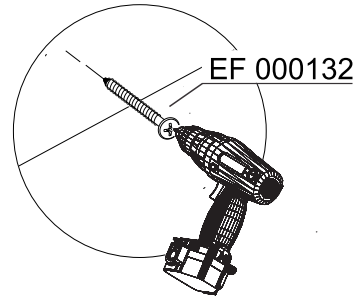
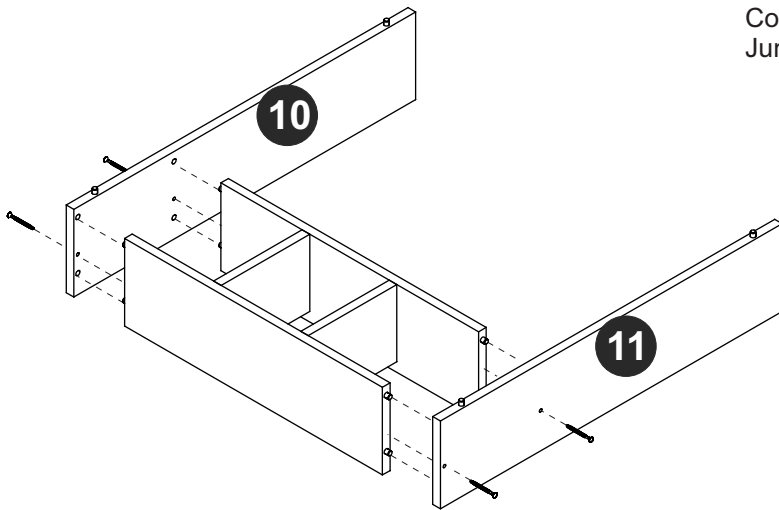

PASSO 15 / STEP 15 / PASO 15

Fixe peça 12 utilizando a ferragem EF 000132.
Fix the piece 12 using hardware EF 000132.
Fije la pieza using el herraje EF 000132.

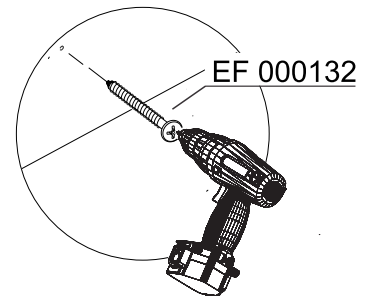
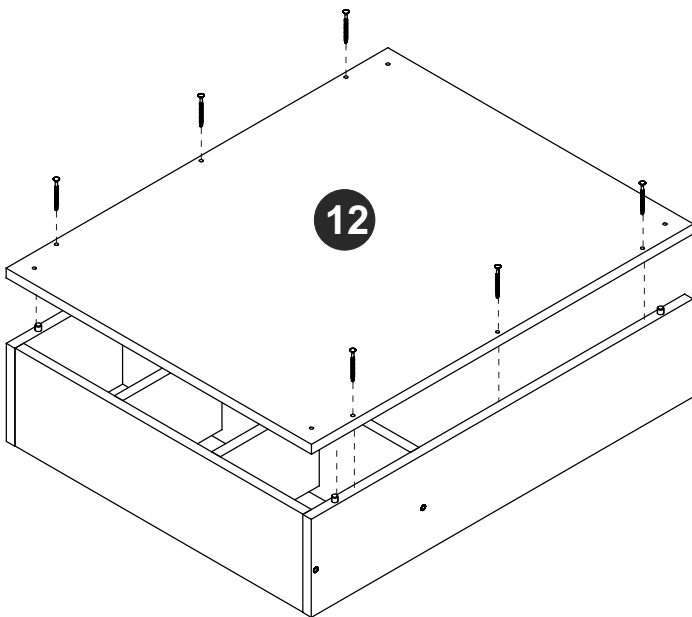

PASSO 16 / STEP 16 / PASO 16

Perfore a parede e insira a ferragem EF 000016. Fixe o móvel na parede utilizando a ferragem EF 000146 e encaixe a capa plastica.
Drill the wall and insert hardware EF 000016. Attach the furniture on the wall using hardware EF 000146 and fit the plastic cover.
Perfore la pared y añade el herraje EF 000016. Fije el mueble en la pared utilizando el herraje EF 000146 y añade la capa plastica.

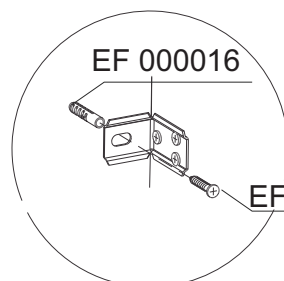
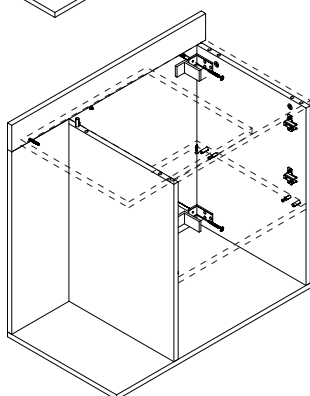
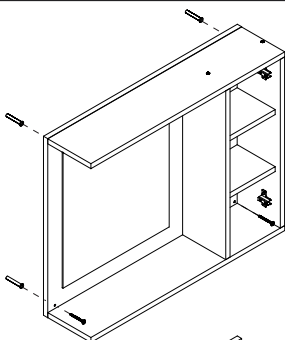

EF 000146
Capa plástica
Plastic cover
Capa plastica

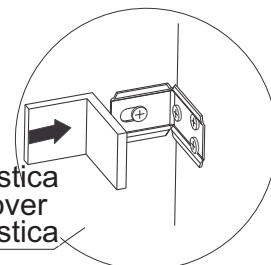

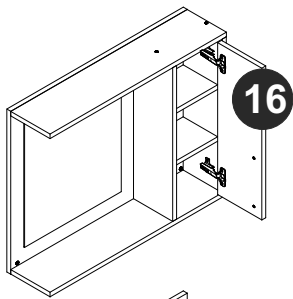

16

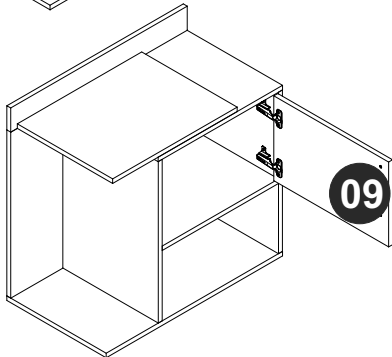

09

PASSO 17 / STEP 17 / PASO 17

Conecte as peça 09 e 16 ao móvel montado.
Connect pieces 09 and 16 to the assembled furniture.
Junte las piezas 09 y 16 al mueble armado.

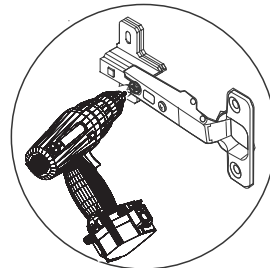

PASSO 18 / STEP 18 / PASO 18

Utilize o tapa furos para cobrir os parafusos aparentes.
Use the sticker to cover the apparent screws.
Utilice los tapa huecos para cubrir los tornillos aparentes.

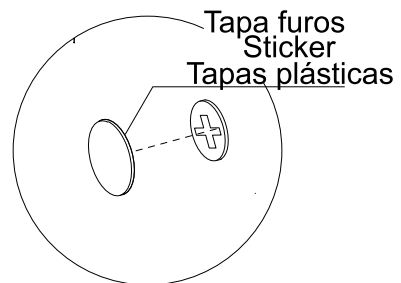
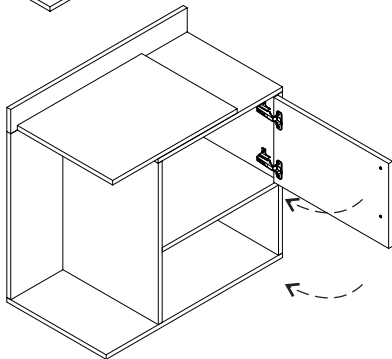
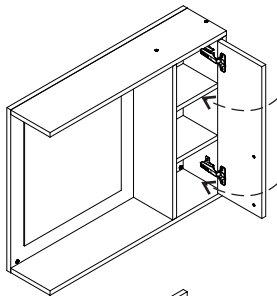

Tapa furos
Sticker
Tapas plásticas

PASSO 19 / STEP 19 / PASO 19

Utilize o giz para dar o acabamento final ao produto.
Use the chalk to give the final finish on the product.
Utilize la tiza para dar el acabado final al producto.

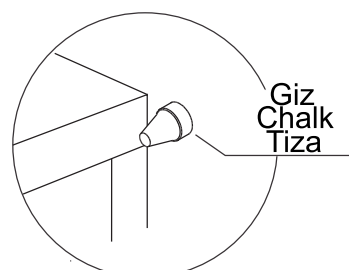
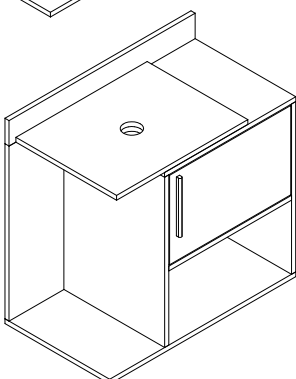
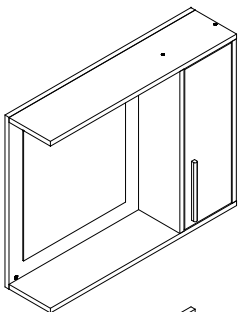

Giz
Chalk
Tiza

